

Minimization of Distortion During Gas Metal Arc Welding Process: A Review

Shashin M. Vyas^{1,}, Sagar I. Shah², G.D. Acharya³*

¹PG Scholar, Department of Production Engineering, Atmiya Institute of Technology and Science, Rajkot, Affiliated to Gujarat Technological University, India

²Assistant Professor, Department of Mechanical Engineering, Atmiya Institute of Technology and Science, Rajkot, Affiliated to Gujarat Technological University, India

³Principal, Department of Mechanical Engineering, Atmiya Institute of Technology and Science, Rajkot, Affiliated to Gujarat Technological University, India

Abstract

The gas metal arc welding (MIG) process is widely used in many appliances because of its versatility. For GMAW process, metals like carbon steel, stainless steel, aluminium, copper, low-alloy steel are widely used in all positions. Butt joint, lap joint, T-joint, edge joint, corner joint are the common types of joints used in welding. The change of shape and dimensions that occur after welding is known as distortion that leads to undesirable results. And to overcome this, it requires mitigation of distortion within the limits. A large number of resources are used now a day for reworking the welds. But it causes higher cost of production and delay for completing the work. Higher amount of residual stresses may generate if the distortion is controlled physically during welding. This work is aimed to predict and reduce distortion with MIG welding process parameters. Using various designs of experiments methods, straight and indirect effects of the process parameters can be determined and process parameters can be optimized.

Keywords: Gas metal arc welding, distortion, parameter optimization, design of experiments

*Author for Correspondence E-mail: vyassameer654@gmail.com

INTRODUCTION

Welding is one of the most dependable, effective, and economical way of fabrication work used for joining metals. Gas metal arc welding (GMAW) is one of the widely used welding processes among other processes that have been applicable for a varying range of plate thicknesses because of its effectiveness, ease of operation and increases production rate [1].

As shown in Figure 1, the operating range of current in this process is 100–500 amperes. The wire speed is controlled by an automatic wire feeder called spool. The range of filler wire diameter is within the limit of 0.5 to 1.2 mm. For protecting the molten metal weld pool from atmospheric gases, An Auxiliary shielding gas is used.

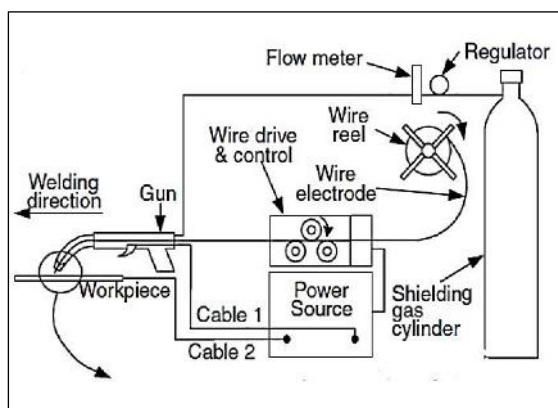

Fig. 1: Gas Metal Arc Welding Setup.

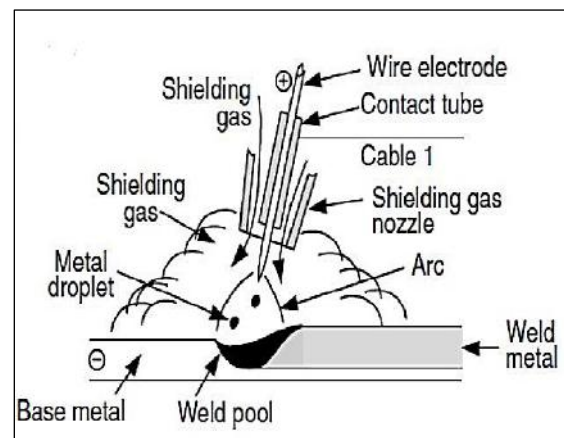

Fig. 2: Gas Metal Arc Welding Process.

As shown in Figure 2, when the base metal and filler metal are melted and solidified, the weld is formed. In order to achieve a good quality weld, an inert or active gas is used during this process. The gas is continuously flown in order to protect the weld pool [2].

It is very essential to optimize the parameters in manufacturing in order to minimize the various defects. For improving the quality of welded joints, the input parameters are very important. Various process parameters that may affect the welding quality should be determined and their condition during welding must be known.

DISTORTION IN WELDING

Among various types of defects in welding, distortion is very challengeable type of defect. Due to uneven transverse shrinkage along the depth of weld, this type of defect occurs [3]. Due to localized heating in welding, the thermal stresses get increased and thus increase the amount of distortion. During weld heat and cooling cycles, residual stresses get increases because of uneven heat distribution [4].

The amount of distortion is affected by:

- 1) The sequence of weld pass,
- 2) The Amount of depth and fusion zone according to thickness of the plate,
- 3) Joint configuration,
- 4) Various material properties, and
- 5) Process parameters in welding [5].

Correction of distortion often requires additional after-weld reworks, which are usually costly, time consuming, and practical only in the most crucial applications. The best practice to minimize or control distortion is proper welding process design through careful selection of various welding input parameters.

Several process parameters influence welding distortion. Better control of these parameters will eliminate the conditions that promote distortion [6].

In recent years, various computer simulation techniques and numerical techniques are used to predict the amount of distortion during welding [1] to predict welding distortion using analytical methods is very difficult. Hence, different statistical and computer simulation techniques are used for predicting various types of welding distortions [5].

A set of experiments is conducted in a defined range of conditions and the experimental results are used to determine the set of parameters that closely meets the joint requirements. However, this type of experimentally determined optimal criteria does not always guarantee the most ideal setting or applicability to the tested conditions [6].

The finite-element method (FEM) is very effective and accurate method for modelling and analyzing different welding processes compared to other numerical methods. Finite element analysis is a very important tool for determining the behavior and relations between sophisticated physical phenomena in the welding process [1].

TYPES OF DISTORTIONS

There are majorly six types of distortions as described below in [Figure 3] [Table 1]:

1. Transverse shrinkage (it is the shrinkage occurring perpendicular to the weld direction).
2. Longitudinal shrinkage (it is the shrinkage occurring in the welding direction).

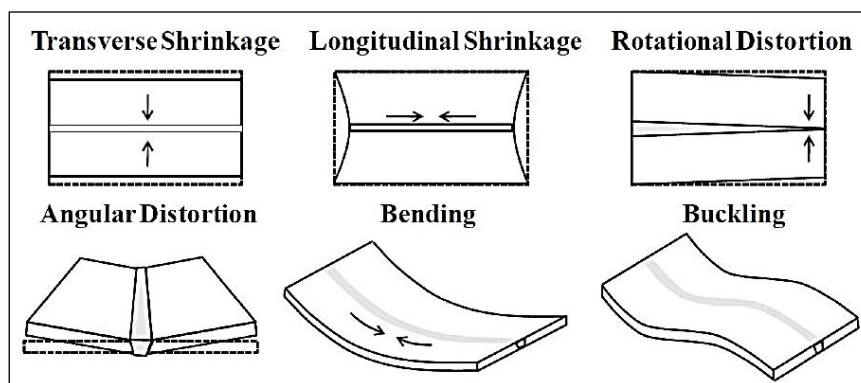

Fig. 3: Types of Distortions.

Table: 1 Distortion Causes and Remedies.

Distortion Type	Causes	Remedies
Transverse Shrinkage	Weld metal hardness problem, constraints applied to weld-joints.	Weld Metal hardness should be sufficient.
Longitudinal Shrinkage	Preheat or fast cooling problem	Weld Short length. Apply sufficient preheat.
Rotational Distortion	Uneven heat flow	Temperature of heat source should be sufficient; weld speed should not be too slow.
Angular Distortion	High amount of heat input	Reduce volume of weld metal, Apply Preheat and post weld treatment.
Bending	Excessive root gaps, excessive heat input.	The root gap should be kept optimum, Double-V Preparation should be done while welding heavy sections
Buckling	Excessive specimen length	Critical length for a given thickness should be considered.

- Rotational distortion (it is a type of angular distortion that takes place because of thermal contraction or expansion in the plane same as the base metal plane).
- Angular distortion (it is the thermal contraction occurring due to uneven distribution of the temperature in the weld direction).
- Bending distortion (it is the distortion that is perpendicular to the base plate and takes place through the weld line).
- Buckling (when the amount of compressive stresses exceed the desired limit, buckling distortion occurs) [7].

BENDING DISTORTION IN WELDING

Contraction forces acting along the line of weld will pull the ends of the weld towards each other. This creates what is commonly termed “longitudinal distortion” as shown in Figure 4.

There are mainly two causes of bending distortion:

- Excessive Root gaps
- Excessive Heat Input

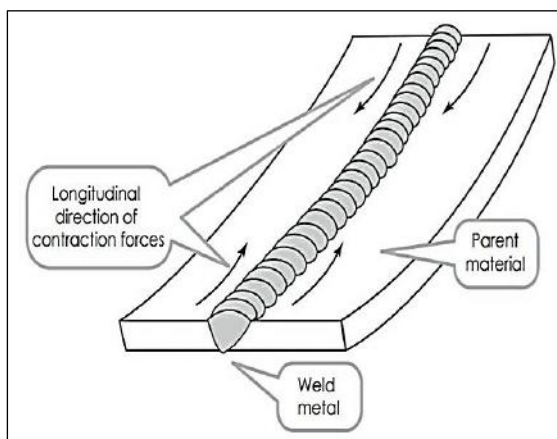

Fig. 4: Bending Distortion during Welding.

Case Study

Bending Distortion that may occur in block of a hydraulic shearing machine is shown in Figure 5.

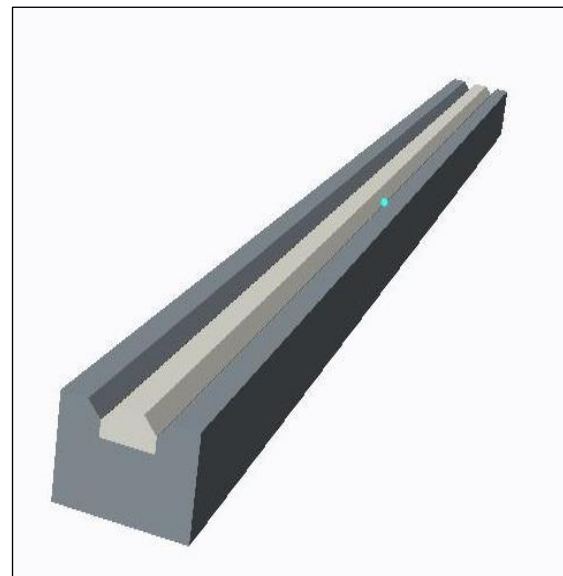

Fig. 5: Hydraulic Shearing Machine Block (Before Welding).

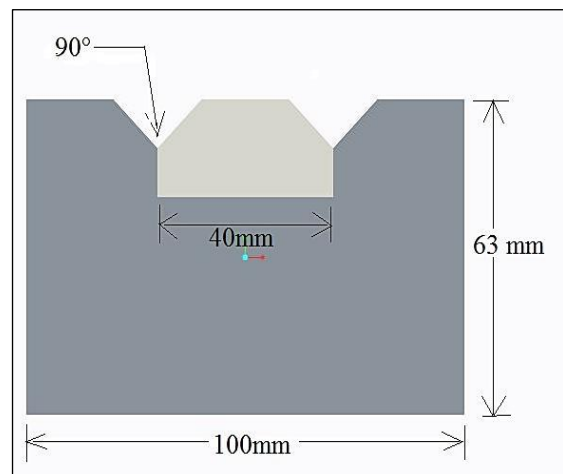

Fig. 6: Hydraulic Shearing Machine Block and Strip to be Welded.

HEAT INPUT REQUIRED

$$Q = \left(\frac{V \cdot I \cdot 60}{S \cdot 1000} \right) * \text{Efficiency}$$

Q = heat energy from the source (kJ/mm)

V = Electrical Potential (V)

I = Welding current (A)

S = Speed of Weld travel (mm/min)

Efficiency of GMAW = 0.85

The specimen shown in Figure [6, 7] is 1525 mm in length and 63 mm thick.



Fig. 7: Distorted Block after Welding.

LONGITUDINAL BENDING

$$\text{Bending} = \left(\frac{0.005 \cdot A \cdot d \cdot L^2}{I} \right), \text{mm}$$

A= Cross section area of the weld, mm²

I= Moment of inertia of the section, mm⁴.

d=Distance from C.G. to outermost fiber, mm.

L= Length of the weld, mm.

To avoid bending distortion, heat input should be optimized by optimizing current, voltage and travel speed. Apart from this, the gap between joints can also be optimized in order to minimize the distortion.

FACTORS AFFECTING DISTORTION IN GMAW

Various welding process parameters are taken into consideration for optimizing mechanical properties, microstructure, and weld bead geometry. The significance of some parameters is given below:

Voltage

- The voltage in arc welding is the amount of drop of the voltage occurring at the electrode and the arc. This voltage drop v in welding is known as the "arc voltage".
- The value of distortion increases with increase in voltage.

Current

The primary source of heating the base plate is current that flows through the arc. The stream of electrons across the arc is termed as the current. Potential, kinetic and Thermal energy are carried out by the current. When the electrons

strike to the base plate, these three types of energy are released as heat. Current is the most affecting parameter in welding, and this is because, it is the main source of heat, increase in current will increase the distortion.

Travel Speed

Base plate is heated by the amount of heat transferred from heat source. The heat source velocity is known as the travel speed. If the heat input from the arc is kept constant, the heat energy to be delivered to the base plate will increase as the travel speed decreases. Distortion will reduce if the travel speed is increased.

Wire Feed Rate

Wire feed rate is also known as the metal deposition rate. The filler metal from the spool is fed into the weld pool at constant speed. Thus, wire feed rate is the amount of metal deposited per unit time. Wire feed rate is inversely proportional to distortion.

Gas Flow Rate

The amount of gas flowing per unit time is known as the gas flow rate. Gases like inert or active gas are used for providing shield to the weld pool in order to protect it from atmospheric gases. The gas flow rate will determine the amount of depth of melting and thus it will affect the dilution. Gas flow rate has very negligible effect on distortion.

EFFECT OF PROCESS PARAMETERS

Ramani. S, Vel Murugan V. have considered voltage, gap between nozzle and plate, feed rate of the wire and electrode angle as process parameters. From experiments, it was concluded that the values of voltage and electrode angle directly proportional to the angular distortion where gap between nozzle and plate and feed rate of the wire have inverse effects.

Lohate M.S, Dr. Damale A.V. has checked the effects of feed rate of the wire, number of passes, the gap of time between two passes on angular distortion. It was found that number of passes has strong effect on distortion, where feed rate of the wire and time gap between two passes negatively affect the distortion as shown in Figure 8.

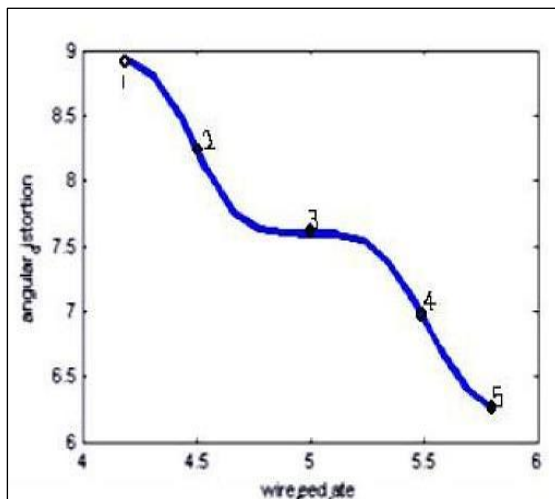

Fig. 8: Wire Feed Rate (mm) versus Distortion (Degree) [3].

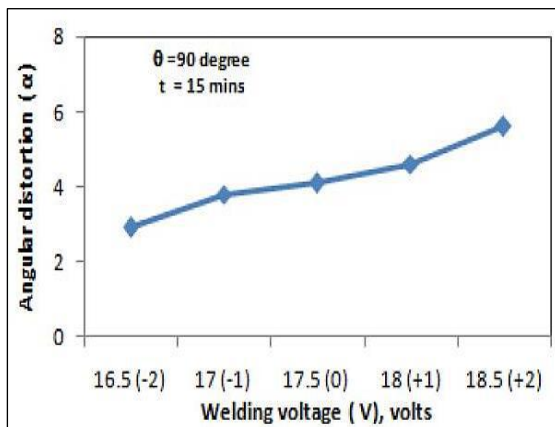

Fig. 9: Welding Voltage (V) versus Distortion (degree) [8].

Aniket Narwadkar and Santosh Bhosle have optimized voltage, current and the rate of gas flow to minimize distortion. They concluded that the amount of angular distortion would increase with increase in voltage and current. i.e. heat input. But the amount of angular distortion would decrease with increase in the rate of gas flow as shown in Figure 9.

A. Sakri, M. Guidara, F. Elhalouani have simulated welding distortion and residual stresses using FEA with experimental validation. It was found that the distortion is mainly affected by joint geometry. Angular distortion increases with increase in included angle of Vee-preparation.

Praful Kumar optimized process parameters like, Joint gap, number of passes and time

between successive passes to reduce distortion using factorial design. He concluded that distortion increases with increase in joint gap and number of passes where time between successive passes has inverse effect on distortion [9].

M. Islam, A.Buijk, *et al.* have performed simulation based optimization for reducing distortion. Simulation was done using Simufact Welding and optimization was done using Generic Algorithm. The parameters like voltage, current and welding speed were considered. It was found that distortion can be reduced up to 41% using GA optimization [10].

Atul kumar has performed design of experiments in order to minimize angular distortion. He concluded that number of passes and joint gap directly affect angular distortion, when time between two passes has inverse effect [11].

Shakti Soni and Nakul aggarwal have performed taguchi optimization method for mitigation of angular distortion. It was found that current, electrode diameter and plate length have direct effect and time between two passes has inverse effect on angular distortion [12].

Yupiter H.P. Manurung, *et. Al.* performed Finite Element Simulation of combined T-joint and butt joint to predict distortion using SYSWELD 2010. The percentage error between experimental and simulation results was found to be 6–17% due to dimensional inaccuracy and fluctuating process parameters.

CONCLUSIONS

For mitigation of welding distortion, various mechanical, thermal methods can be used. But they might lead to increase in residual stresses. This can be overcome by optimizing various parameters during GMAW process.

From the researches done on reducing distortion, it can be observed that factors like number of passes, time between successive passes, joint gap, and welding current mainly affect welding distortion. For achieving minimum distortion, these factors are optimized within the limits using various optimization techniques.

REFERENCES

1. Lohate MS, Damale AV. Fuzzy Based Prediction of Angular Distortion of Gas Metal Arc Welded Structural Steel Plates. *International Journal of Innovation in Engineering, Research and Technology*. 1- A10p.
2. H.P. Manurung Y, Lidam RN, Rahim MR et al. Welding distortion analysis of multipass joint combination with different sequences using 3D FEM and experiment. *International Journal of Pressure Vessels and Piping*. 2013; xxx: 1–10p.
3. Ramani S, Vel Murugan V. Effect of Process Parameters on Angular Distortion of MIG Welded Ai6061 Plates; All India Manufacturing Technology, Design and Research Conference. Dec 2014; 401-1-401-6p.
4. Narwadkar A, Bhosle S. Optimization of MIG Welding Parameters to Control the Angular Distortion in Fe410WA. *Steel Journal of Materials Processing Technology*. 2005; 160: 70–76p.
5. Pazooki AMA, Hermans MJM, Richardson IM. Control of welding distortion during gas metal arc welding of AH36 plates by stress engineering. *International Journal of Advanced Manufacturing Technology*. 2017; 88: 1439–1457p.
6. Vel Murugan V, Gunaraj V. Effects of Process Parameters on Angular Distortion of Gas Metal Arc Welded Structural Steel Plates. *Supplement to The Welding Journal*. Nov 2005; 165–171p.
7. Sakri, Guidara M, Elhalouani F. Numerical simulation of MIG type arc welding induced residual stresses and distortions in thin sheets of S235 steel. *Materials Science and Engineering*. 2010; 13: 1–8p.
8. Mukhopadhyay P, Chattopadhyaya S, Bhatia S, et al. Prediction of weld parameters in Gas Metal Arc Welding Process using curve fitting techniques and graphical methods. *Advanced Materials Research Vols*. Jan 2015; 652-654: 2352–2356p.
9. Kumar P. Parametric Optimization of Angular Distortion on Mild Steel by Using MIG Welding. *International Journal of Advanced Engineering Technology*. 41–46p.
10. Islam M, Buijk A, Rais-Rohani M, Motoyama K. Simulation-based numerical optimization of arc welding process for reduced distortion in welded structures. *Finite Elements in Analysis and Design*. 2014; 84: 54–64p.
11. Kumar A. Effect of Various Parameters on Angular Distortion in Welding. *International Journal of Current Engineering and Technology*. Dec 2011; 132–136p.
12. Soni S, Aggarwal N. Optimization of Distortion in Welding. *International Journal of Enhanced Research in Science, Technology & Engineering*. Jul 2015; 4(7): 128–133p.

Cite this Article

Shashin M Vyas, Sagar I. Shah, G.D. Acharya. Minimization of Distortion During Gas Metal Arc Welding Process: A Review. *Journal of Experimental & Applied Mechanics*. 2017; 8(3): 48–53p.