

## FDM – Everything You Need to Know: A Review

**Himat R. Rathod<sup>1</sup>, Rishabh D. Makwana<sup>2,\*</sup>, Biren J. Saradava<sup>3</sup>, G. D. Acharya<sup>4</sup>**

<sup>1</sup>PG Scholar, Mechanical Eng. Dept., AITS Rajkot

<sup>2</sup>Assistant Professor, Mechanical Eng. Dept., AITS Rajkot

<sup>3</sup>Assistant Professor, Mechanical Eng. Dept., AITS Rajkot

<sup>4</sup>Principal, AITS Rajkot

### Abstract

The full form of FDM is fused deposition modelling, it is often referred to as 3D printing, additive manufacturing is in truth a technology which has been around for in any event three decades. There are in reality various diverse sub types of additive manufacturing including 3D printing, yet additionally quick prototyping and direct advanced assembling. Late advances in this innovation have seen its utilization become unquestionably increasingly far reaching and it offers energizing opportunities for future turn of events. Conventional assembling strategies include a material being cut or formed into the ideal item by parts of it being evacuated in an assortment of ways. The procedure includes the utilization of a PC and exceptional CAD software which can transfer messages to the printer so it "prints" in the ideal shape. Appropriate for use with a scope of various materials, the cartridge is stacked with the pertinent substance and this is "printed" into the shape, each skinny layer in turn. These layers are over and again imprinted on head of one another, being melded during the procedure until the shape is finished. Customary assembling methods are equipped for creating an extraordinary scope of shapes and structures however added substance fabricating takes creation to the following level. One of the greatest benefits of this more modern technology is the greater range of shapes which can be produced. Designs that can't be manufactured in one entire piece with traditional means can easily be achieved. This has the advantage of being stronger; no weak spots which can be compromised or stressed. Although media likes to use the term "3D Printing" as a synonym for all Additive Manufacturing processes, there are actually lots of individual processes which vary in their method of layer manufacturing. Individual processes will differ depending on the material and machine technology used. This review paper deals with basic principal, advantages, drawback's and factors affecting selection of process. It also covers the quality parameters of FDM product.

**Keywords:** FDM Process, 3D Printing Technology, Additive Manufacturing

**\*Author for Correspondence** E-mail: rdmakwana@aits.edu.in

### INTRODUCTION

Before delving into the advantages, let's understand what exactly fused deposition modelling. Also known as fused filament fabrication, FDM involves building of an object by deposited melted filament layer-by-layer.

The deposition of melted material takes place in a predetermined path Fused deposition modeling is an additive manufacturing processes forms used to create the complex parts from CAD models. In this process the parts are worked from slim layers of expelled fibers of a semi melted thermoplastic.[1] The

mechanical properties of FDM parts are rely upon variable factors, for example, the material's storing direction, fiber's stream rate, raster's partition, and expulsion temperatures and so forth. Strong and shell are the two primary FDM producing methodologies utilized indistinctively; be that as it may, there are not many applications where the strong form methodology may not be important and even dangerous. In FDM process there is a spout which can portable in x-y course on to a substrate stores string of liquid polymeric material, after expulsion and welds to the past layer as appeared in Figure 1. [4]

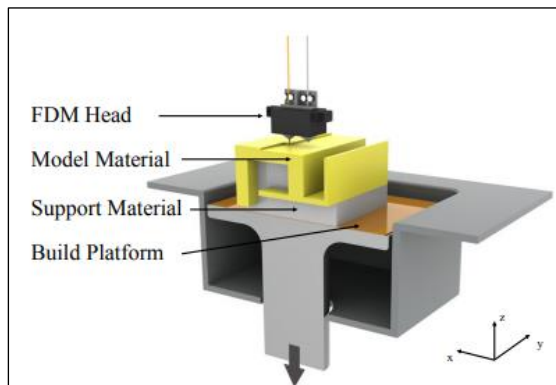

**Fig. 1:** Fused deposition Technology [4].

### Advantages of this 3D Printing

#### *Reasonable pricing*

First of all, printers with FDM technology are extremely reasonably priced. This is why it is preferred for home use. The filaments for this printer, ceramic and thermoplastic, are also economical than other popular options. Even the replacement of the parts don't require spending too much. This is one of the major reasons behind popularity of FDM printers in India.

#### *Consumes less time*

The time it takes to print the entire object isn't too much. You can get simple prints in less than a day. For complex designs, it hardly takes less than a day.

But, you don't need to spend time on post-processing for the majority of 3D prints. Use them as soon as they are printed. Well, this is another factor that makes it cheaper.

#### *Numerous filaments to choose from*

It is easier and economical to switch materials for printing, as the range of filaments is broad. Printing of complex models isn't a challenge, as it is possible to select print numerous materials simultaneously. What this means is that printing of complex models isn't a challenge anymore. For support materials (PVA or HIPS), an additional print head could be used.

#### *Ease of use*

Numerous individuals and educational institutions from India prefer this 3D printer specifically because it is easy to use. Both teachers and students can learn the basics in hardly two to three days. Even the companies

that want to start a business related to 3D printed objects can opt for this variant, as they don't need prior experience.

### Drawbacks

An issue with FDM printer is that detailing isn't possible. But, that's an issue if we are considering 3D printing for objects that require great precision. For learners, hobbyists, and tinkering, this won't pose as a major issue. Even rapid prototyping of numerous products is possible with it.

There are several methods of 3D printing, but fused deposition modeling, or FDM, is the most common. Using a thermoforming technique, FDM can quickly and affordably fabricate prototyped products and their parts. As a non-laser-based process, it's frequently used by engineers and designers to create and perfect their ideas before mass production.

### Why Choose FDM for 3D Printing?

#### *Speed*

Parts produced with FDM can be ready in a few minutes or couple of hours, making it one of the fastest choices in 3D printing. For example, CAD drawings can be transformed into finished products in only one step.

#### *Accuracy*

FDM printers use a thermoplastic filament that is heated to a melting point and then extracted in layers to create a three-dimensional object. The process is accurate to within 0.005 inches, according to the School of Computer Science at Carnegie Mellon University.

#### *Affordability*

The FDM process uses thermoplastic and ceramic filament that is affordable compared to the alternatives. The modest size of the printers also means parts don't have to be manufactured in a large facility, helping to lower the expense of producing small components.

#### *Scaling*

This version of 3D printing automatically scales parts down to size to fit inside a production space without losing accuracy. Users can create miniature prototypes to use in presentations or as scaled-down examples in sales.

## LITERATURE REVIEW

Literature review is an important part of any review or research paper for understanding:

1. The important aspects of work;
2. A data source that work used;
3. Ideas for further consideration, etc.

Here is the summary of work or experiments for brief understanding of process parameters of end milling operation with details of papers published and input-output parameters studied by some authors.

Paleti, et al.[1] has explained about work the influence of the orientation and the mechanical data are analyzed. Sample parts are generated with the given parameters of the native software based upon the CAD data. First, specimens were analyzed concerning their geometry and configuration. The dimensions and weight were measured. The mechanical tests conducted were the tensile and compression tests.

Navuri et al.[2] has given the study it can be observed that solid structure has high compressive strength and high material used. hollow internal structure has less fabrication time, low material used. Therefore strength to weight ratio is required regard less of fabrication time. Solid internal structure is recommended to weight is not a critical factor.

Anoosha, et al.[3] has explained about the investigation are based on maximum tensile test it found that 230° C temperature, 16 mm/s feed rate and layer thickness are the optimum level building model in different orientation, FEM analysis using ANSYS on tensile test the model 45° orientation has maximum tensile stress, model built at 0° orientation and model built at 90° orientation has less tensile strength.

Knoop, et al.[4] it investigations were conducted with the polymer Polyamide 12 (FDM Nylon 12) from Stratasys Inc. This polymer can be processed with layer thicknesses from 178 µm to 330 µm. Thus, the mechanical properties were determined for these layer thicknesses and for different orientations on the build platform. In addition to the mechanical properties the thermal properties (e.g. with a DSC analysis) are also investigated.

Bagsik, et al.[5] work the influence of the orientation and the structure of the manufactured parts based on the mechanical data are analyzed. Sample parts are generated with the given parameters of the native software based upon the CAD data. First, specimens were analyzed concerning their geometry and configuration. The dimensions and weight were measured. The mechanical tests conducted were the tensile and compression tests.

Kovan, et al. [6] has given the study of effect the surface roughens on layer thickness a printing temperature of PLA. That printing parameter have very important role in surface roughness, increasing layer thickens at printing temperature in upright direction surface roughness value. The printing temperature lower better surface quality.

Galantucci, et al. [7] The investigation of research was to determine the impact of sample's structure and building orientation on the tensile strength of 3D printed samples and thus to determine the combination that provides the highest strength. Test samples were prepared on a Z Corporation's 3D printer model Z310, with variations of internal geometrical structure, variations of longitudinal orientation and also variations of base alignment.

Basavaraj, et al. [8] main focused discusses the process parameters for fused deposition modelling (FDM). Layer thickness, Orientation angle and shell thickness are the process variables considered for studies.

Farbman, et al.[9] has an experiment the various mechanical properties of 3D printing materiel due to various factors there are many factor need to analyze when come to predicting the strength of 3D printing part. It's clear of limited number and limited quality samples it's used the provide results. Components will want to know how maximize the strength and durability of product.

Kucewicz, et al.[10] three different topologies with similar relative densities were designed and fabricated by fused deposition modelling of ABS plus material. In the first stage, the material properties of the samples were

evaluated and numerically correlated with experimental data. Experimental compression tests were performed on a universal strength machine. The comparison of the results of experiments and finite element analyses indicated acceptable similarity in terms of deformation, failure and force characteristics. Additionally, a mesh sensitivity study was performed, and the influence of the mesh on the obtained results was assessed.

Joshi, et al.[11] investigates a 3D printing is definitely revolutionizing the world of manufacturing, even in a most advanced and sophisticated industry like aerospace industry. This industry works around 2 basic principle requirements – low weight and high safety. 3D printing has been able to aid reduction in weight through complex and net shape manufacturing with less number of joints and intricate geometry. However, from the safety aspect, it is still a long way before being the reliable standard. Many challenges, such as printing patterns, porosity built-up, and uneven print flow, need to be solved and eliminated completely. It is just a matter of time. Once that happens, 3D printing would replace more and more traditional manufacturing techniques currently used in the aerospace industry and will definitely have a sustained adaptation and growth.

Ngo, et al.[12] describes a different methods, fused deposition modelling (FDM) is one of the most common 3D printing technologies because of low-cost, simplicity and high-speed processing. It is originally used for 3D printing of polymer filaments but has been adapted to many other materials. FDM is mainly used for fast prototyping, and the mechanical properties and quality of the printed parts are lower compared to the powder-bed methods such as selective laser sintering (SLS) and selective laser melting (SLM). Adjacent powders are fused, melted or bonded together by using an auxiliary adhesive in Powder-bed methods, which result in finer resolutions but incur higher costs and are slower processes. However, it is a slow and complex procedure that is restricted by a limited number of materials. Finally, laminated object manufacturing (LOM) is based on layer-by-

layer cutting and lamination of sheets or rolls of materials.

Angrish, et al.[13] has focused on a direct production of near-net functional parts in a short interval of time is another proof of the high relevance of additive manufacturing technologies which can be used in aerospace sector. The technology is still being developed to reduce the time taken to build the structures (especially with metals), improve surface finish, part strength and reduction of layer thickness. But the fact of the matter is that the technology is still not ready for large-scale production of aerospace components.

Kumar, et al.[14] has expended of latest additive manufacturing processes like Laser Metal Deposition, Laser Cladding, Electron Beam Melting, Direct Metal Laser Sintering, Selective Laser Melting and advanced high temperature super alloys have drastically enhanced the applications of additive manufacturing technology in the aerospace industry. The increased demand for complex and lightweight metal parts such as turbine disc with blades, stator and rotor turbine vane assemblies, combustion chamber and fuel nozzle.

## SUMMARY OF LITERATURE

For quality outcome for FDM one should consider various process parameters i.e. layer thickness, orientation angle, shell thickness, raster angle, air gap, nozzle temperature and internal structure. These process parameters affect the mechanical properties of FDM product.

## CONCLUSION

The review concludes that majority of aerospace applications is done with additive manufacturing method with consideration of FDM, SLS, LOM and SLM, it is very suitable for aerospace applications as light weight material is used. Many researchers has concluded that it also gives high tensile strength with less weight as compared to other metal parts.

## REFERENCES

1. Paleti, B. M., Navuri, K., Eswara Kumar, A., Teja, P. V. S., & Vaddeswaram,

- ANALYSIS OF EFFECT OF INTERNAL STRUCTURES ON TENSILE STRENGTH OF THE FDM PARTS. *International Journal of Pure and Applied Mathematics*, 2017, 115(6), 123-131.
2. Paleti, B. M., Navuri, K., Eswara Kumar, A., Teja, P. V. S., & Vaddeswaram A. Effect of internal structures on compressive strength of the FDM parts. *International Journal of Pure and Applied Mathematics*, 2017, 115(6), 139-146.
  3. Anoosha N M, Sachin B, Hemanth B R, Pavan Kumar. Tensile test & FEM Analysis of ABS material using FDM Technique. *International Journal of innovation Research in Science Engineering and Technology*. 2018, Volume 7 No. 6 6658 - 6663
  4. Knoop, F., Schoeppner, V., & Knoop, F. C. Mechanical and thermal properties of FDM parts manufactured with polyamide 12. In *Proceedings of the 26th Annual International Solid Freeform Fabrication Symposium—an Additive Manufacturing Conference, Austin, TX, USA 2015*, (pp. 10-12).
  5. Bagsik, K. I., Gebisa, A. W., & Lemu, H. G. Mechanical properties of ULTEM 9085 material processed by fused deposition modeling. *Polymer Testing*, 2018. 72, 335-347.
  6. Kovan, V., Tezel, T., Topal, E. S., & Camurlu, H. E. Printing parameters effect on surface characteristics of 3D printed PLA materials. *Machines. Technologies. Materials*. 2018, 12(7), 266-269.
  7. Galantucci, L. M., Bodi, I., Kacani, J., & Lavecchia, F. Analysis of dimensional performance for a 3D open-source printer based on fused deposition modeling technique. *Procedia Cirp*, 2015, 28, 82-87.
  8. Basavaraj, C. K., & Vishwas, M. Studies on effect of fused deposition modelling process parameters on ultimate tensile strength and dimensional accuracy of nylon. In *IOP conference series:materials science and engineering*. 2016, (Vol. 149, p. 012035).
  9. Farbman, D., & McCoy, C. Materials testing of 3D printed ABS and PLA samples to guide mechanical design. In *International Manufacturing Science and Engineering Conference 2016*, (Vol. 49903, p. V002T01A015). American Society of Mechanical Engineers
  10. Kucewicz, M., Baranowski, P., Małachowski, J., Popławski, A., & Płatek, P. Modelling, and characterization of 3D printed cellular structures. *Materials & Design*, 2018, 142, 177-189.
  11. Joshi, S. C., & Sheikh, A. A. 3D printing in aerospace and its long-term sustainability. *Virtual and Physical Prototyping*, 2015, 10(4), 175-185.
  12. Ngo, T. D., Kashani, A., Imbalzano, G., Nguyen, K. T., & Hui, D. Additive manufacturing (3D printing): A review of materials, methods, applications and challenges. *Composites Part B: Engineering*, 2018, 143, 172-196.
  13. Angrish, A. A critical analysis of additive manufacturing technologies for aerospace applications. In *2014 IEEE Aerospace Conference* (pp. 1-6).
  14. Kumar, L. J., & Nair, C. K. (2017). Current trends of additive manufacturing in the aerospace industry. In *Advances in 3D printing & additive manufacturing technologies* (pp. 39-54). Springer, Singapore

#### Cite this Article

Himat R. Rathod, Rishabh D. Makwana, Biren J. Saradava, G. D. Acharya. FDM – Everything You Need to Know: A Review. *Trends in Mechanical Engineering & Technology*. 2020; 10(2): 14–18p.