

## Component Fastening by Using Snap-On Tools Replacing Traditional Fasteners

*Niraj Vangani\**, *Manhar Kagthara*

Mechanical Department, Atmiya Institute of Technology & Science, Rajkot, Gujarat, India

### **Abstract**

*The traditional fasteners connect the next part in different assemblies with the help of bolt, nuts and other fasteners. But main problem starts when motion passes through the assemblies; it may make the assemblies weak due to improper fastening or sometimes motion is that much rapid that it makes these fasteners weak from the joints. Because of that, the assembly may get disassembled and may damage other parts and leads to catastrophic failure. Another problem considering tightening & loosening of fasteners takes too much time; whereas Snap fits are the tools which make assembly easy to maintain and provide ease of unlocking which saves the time for production. In this research, by using the design of X concept which suggests replacing screw-nut type fasteners with Snap fits in DFA approach. So here, the main aim is to replace fasteners with modern Snap-on tools which secure high strength to withstand desired motions and emphasizing on ease of locking and unlocking with snapping by improving stress criterions. So having said that, with the use of some quality parameters in design for making this type of modern tools and put them into the production process for increasing efficiency and life of the mechanical components.*

**Keywords:** Snap tools, Snap fits, traditional fasteners, DFA approach

**\*Author for Correspondence** E-mail: nrvangani@aits.edu.in

### **INTRODUCTION**

First of all, what are the four key components of the Snap-on? According to price, product, place and promotion analysis of Snap-on, mainly four key components are easy to be recognized and concluded.

Nowadays, Snap-on products are high quality standards and considered as a “gold standard” by tool-lovers. Snap-on tools are satisfying because of their utility. Second thing, Snap-on tools has a premium pricing strategy—about 10% higher than its direct competitors. On the other side, Snap-on insists on a credit program of selling to mechanics on credit with weekly time payment. This deal is a great deal for mechanics because they do not have to pay a possible high cost immediately when they buy some tools. This measure is also a wise decision for Snap-on because it can increase the sales volume and revenue. Third terminology is that Snap-on has a good promotion strategy because it communicates with customer effectively. It attracts mechanic consumers who need plenty of tools when they work as its core customers.

These snap joints are a very precise, readily economical, simple and quicker way of assembling two different components. Each & every types of snap joints are having common principle that a protruding part of one component, e.g., a hook, stud or screw-nuts deflected briefly during the joining operation and catches in a depression (undercut) in the mating component. After completing joining operation, the Snap-fits features should be returned to its stress-free condition. These joints could be separable as well as inseparable depending upon the shapes of the undercut taken and the required force to separate the components varies mostly according to the design.

### **TYPES OF SNAP JOINTS**

There are wide number of alternatives available for the snap joints. According to the level of flexibility, plastics are the best fit and suitable materials for joining assemblies. Many design possibilities have been reduced up till now to few of the basic shapes.

Mainly following types of snap joints are available:

- **Cantilever-Type Snap Joints**  
This will consider fluctuating loads and fatigue loads, too.
- **U-Shaped Type Snap Joints**  
Variation cantilever type of load exists here.
- **Torsion-Type Snap Joints**  
Stress which carry these joints are shear stresses.
- **Annular-Type Snap Joints**  
These snap joints are axis symmetrical from the axis of rotation and they generate multiaxial stresses.
- **Snap-On Fork Joints (Figures 1 and 2)**

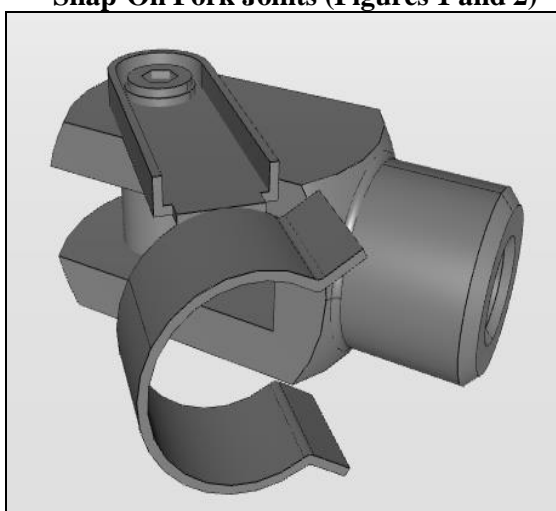

*Fig. 1: Cad Model of Snap-On Fork Pin.*



*Fig. 2: Validated Snap-On Spring Fork Pin in Pneumatic Cylinder.*

### APPLICATIONS OF SNAP-FITS

Key features of the Snap-fit applications are: Snap-fits sort out the problems of making least expensive component equipment that can be

joined easily and quickly with another piece of assembly. An ideal material applied for Snap-fits is thermoplastics, because they are having certain flexibilities and necessary resilience enough to fit for the various assembly and disassembly operations (Figures 3–5).



*Fig. 3: In Bezel of Door Handle.*

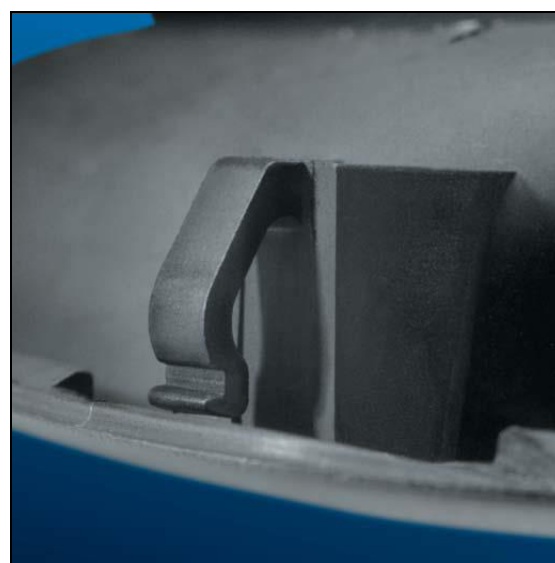

*Fig. 4: Bezel of Backside Door.*



*Fig. 5: Automotive Oil Filter Snaps.*

### LITERATURE SURVEY

Vangani and Mandaliya [1] in their paper “Design & Analysis of fork pin & its assembly in pneumatic cylinder using snap on spring”

replaced the traditional fasteners with the new Snap-on tools. Throughout modeling and analysis of fork pin assembly was carried out in this research paper on the pneumatic cylinder component. The analysis was carried out in Ansys software and modeling was done in the CREO software to run this analysis. Validation was shown at the end to show how good results were obtained with Snap-on tools.

Research paper “Selection and optimization of snap-fit features via web-based software” by Ruan [2], was the core research to develop this concept. In this research, selection criterion were detailed that how to select and what type of Snap-fit was best fit for the particular component as well as what optimization features on which those fits run precisely. According to him, when Snap-fits were used in plastics, they can become simpler, quicker and least expensive method of assembling two or more than two parts. When these Snap-fits were designed in proper manner, all parts joined with Snap-fits can be assembled and disassembled various times without any kind of undesired effects on the assembly. Snap-fits are also capable enough for making products environment friendly because of their ease of disengagement, which makes mechanical equipment’s of different materials easy to recycle. With the development and advancement of Internet, it is also a demanding term for Snap-fit with the web-based design tool which is independent to all the operating systems, even they are easily accessible and can be upgraded universally by upgrading the design tools at the enlarged server location. This whole research is developed on the basis of web-based design tool which is having three various features of Snap-fits—cantilever hook, post & dome, and bayonet & finger [3–9].

Genc *et al.* in their paper [3], “Systematic approach to integral snap-fit attachment design”, basically focused on exclusively locking features of assemblies such as cantilever hooks, compressive hooks, bayonet fingers. This research paper focused on how expressively assembly can fit in desired manners, developing new methodologies and guidelines especially for the plastic parts snap fits. Classifications of features based on

locating, locking and engaging of this was used as basis for the feature thus this works on integral parts for locking the assemblies.

Kshirsagar and Pawar [4], in their paper “Design and Analysis of Snap fit joint in Plastic part” directed towards the software methods to develop this models. This method of assembling was uniquely suited to thermoplastic materials due to their flexibilities, high range elongation and their ability to get molded into complex shapes such as complicated curvatures, contour-shaped structures. In this research paper, a 2D model of snap lock was generated in ANSYS software to study the nonlinear contact analysis between the mating lips. Result generated by the FEA software ANSYS, allows to evaluate and optimize the snap joint prior to committing costly prototypes and tooling.

### **Systematic Approach to Integral Snap-Fit Attachment Design W. Messier**

#### **FUTURE SCOPE**

The main aim of this research is to switch over to the advancing design concepts based on design of x from the traditional approaches. This review paper is giving core idea for replacing traditional fasteners in the small mechanical components. Time consuming problems faced during the assembling and disassembling by these fasteners are eased by using Snap-on concept. These will also ease the locking and unlocking, metal ling and dismantling which is time consuming with the traditional fasteners. Recurring scheme in the fastener designs is to develop the DFA concept based on DFX theory which also strikes to move towards snap fits from traditional fasteners and that will create the scope in this direction further & further.

#### **REFERENCES**

1. Vangani NR, Mandaliya PJ. Design & Analysis of fork pin & its assembly in pneumatic cylinder using snap on spring. *IJAERD*. 2015; 2(5): 337–44p
2. Ruan T. Selection and optimization of snap-fit features Via web-based software. *PhD Dissertation*. Ohio: Ohio State University; 2005.

3. Genc S, Messler Jr. RW, Gabriele GA. Systematic approach to integral snap-fit attachment design. *Research in Engineering Design*. 1998; 10: 84–93p.
4. Kshirsagar RM, Pawar DB. Design and Analysis of Snap fit joint in Plastic part. *IJIERE*. 2015; 2(1): 83–7p.
5. Bayer Polymers Division. *Snap Fit Joints for Plastics –Bayer Material Science*. Pittsburgh, PA: Bayer Material Science LLC; 2000.
6. <http://www.en.m.wikipedia.org>
7. BASF Corporation Engineering Plastics. *Technical Expertise Manual—Snap Fit Design Manual*. New Jersey: BASF Corporation; 2007.
8. Available from: <http://www.vardhmanbearings.com>
9. Available from: <http://www.designsociety.org>

**Cite this Article**

Vangani N, Kagthara M. Component fastening by using Snap-on tools replacing traditional fasteners. *Trends in Mechanical Engineering & Technology*. 2016; 6(1): 31–34p.