

ATMIYA UNIVERSITY

RAJKOT



A

Report On

E-Academy

Under subject of

PROJECT

B.TECH, Semester – VII

(Computer Engineering)

Submitted by:

- | | | |
|---|------------------------------------|-----------|
| 1 | Mathakiya Mahamadavesh Mahebbubhai | 201002017 |
| 2 | Ghodasara Keval Manishbhai | 201002009 |

Prof. Nirali Borad

(Faculty Guide)

Prof. Tosal M. Bhalodia

(Head of the Department)

Academic Year

(2022-23)

CANDIDATE'S DECLARATION

We hereby declare that the work presented in this project entitled “**E-Academy**” submitted towards completion of project in **7th Semester** of B. Tech. (Computer Engineering) is an authentic record of our original work carried out under the guidance of “**Prof. Nirali Borad**”.

We have not submitted the matter embodied in this project for the award of any other degree.

Semester: 7th

Place: Rajkot

Signature:

Mathakiya Mahamadavesh Mahebbubhai (201002017)

Ghudasara Keval Manishbhai(201002009)

ATMIYA UNIVERSITY

RAJKOT



CERTIFICATE

Date:

This is to certify that the “E-Academy” has been carried out by **MATHAKIYA MAHAMADAVESH MAHEBUBBHAI** under my guidance in fulfillment of the subject Project in **COMPUTER ENGINEERING (7th Semester)** of Atmiya University, Rajkot during the academic year 2022.

Prof. Nirali Borad

(Project Guide)

Prof. Tosal M. Bhalodia

(Head of the Department)

ATMIYA UNIVERSITY

RAJKOT



CERTIFICATE

Date:

This is to certify that the “**E-Academy**” has been carried out by **GHODASARA KEVAL MANISHBHAI** under my guidance in fulfillment of the subject Project in **COMPUTER ENGINEERING (7th Semester)** of Atmiya University, Rajkot during the academic year 2022.

Prof. Nirali Borad

(Project Guide)

Prof. Tosal M. Bhalodia

(Head of the Department)

ACKNOWLEDGEMENT

We have taken many efforts in this project. However, it would not have been possible without the kind support and help of many individuals and organizations. We would like to extend our sincere thanks to all of them.

We are highly indebted to **Prof. Nirali Borad** for their guidance and constant supervision as well as for providing necessary information regarding the Mini Project titled “**E-Academy**”. We would like to express our gratitude towards staff members of Computer Engineering Department, Atmiya University for their kind co- operation and encouragement which helped us in completion of this project.

We even thank and appreciate to our colleague in developing the project and people who have willingly helped us out with their abilities.

MATHAKIYA MAHAMADAVESH MAHEBUBBHAI (201002017)

GHODASARA KEVAL MANISHBHAI(201002009)

ABSTRACT

E-Academy tool is a web application which is useful for students who are going to choose any course in higher education, for them this application is helpful to make the correct the decision with the accurate information. In this Course Management application, we are having the module is Student and Instructor. The student must register into the application by providing all the basic and general information after registration student can log in with the default username and password, The Instructor must register into the application by providing all the basic and general information after registration Instructor can log in with the default username and password. Instructor can upload the courses and student will learn the courses as per student requirement. Admin can log using default password and username. And admin check the all user information.

INDEX

Sr. No.	TITLES	Page No.
	Acknowledgement	I
	Abstract	II
	List of Figures	1
	List of Tables	2
1.	Introduction	3
	1.1 Purpose	3
	1.2 Scope	3
	1.3 Technology and tool	4
2.	Project Management	5
	2.1 Project Planning	5
	2.2 Project Scheduling	6
3.	System Requirements Study	7
	3.1 Hardware and Software Requirements	7
4.	System Analysis	8
	4.1 Study of Current System	8
	4.2 Problem and Weaknesses of Current System	8
	4.3 Requirements of New System	8
	4.3.1 User Requirements	8
	4.3.2 System Requirements	9
5.	System Design	10
	5.1 Diagrams	10
	5.2.1 Data Flow Diagram Level 0	10
	5.2.2 Data Flow Diagram Level 1	10
	5.2.3 E-R Diagram	11
	5.2.4 Use Case Diagram	12
	5.2.5 Flow Chart	13
	5.2 Data Dictionary	14
6	Code Implementation	18
	6.1 Screenshots	23

7	Limitations and Future Enhancement	25
	7.1 Advantages & Disadvantages	25
8	Conclusion	26
9	References	27

LIST OF FIGURES

Figure No.	Table Title	Page No.
2.1	Spiral Model	05
5.1.1	DFD Level 0	10
5.1.2	DFD Level 1	10
5.1.3	E-R Diagram	11
5.1.4	Use Case Diagram	12
5.1.5	Flow Chart	13

LIST OF TABLES

Table No.	Table Title	Page No.
5.2.1	User	14
5.2.2	CourseDetails	15
5.2.3	UserCourses	16
5.2.4	CountryMaster	16
5.2.5	StateMaster	17

CHAPTER – 1 INTRODUCTION

1.1. Purpose

Course Management System tool is a web application which is useful for students who are going to choose any course in higher education, for them this application is helpful to make the correct the decision with the accurate information.

1.2. Scope

As the technology and the passion of being muscular and healthy is increasing day by day. So, the need for a well-organized, computer base gymnasium Management System has become the need of society and the gymnasium industry.

This system helps the Owner and Admin to maintain large data about users and their daily transactions in the gymnasium.

The following modules are used in this system:

- I. Admin Modules.
- II. Instructor Modules.
- III. Student Modules.

➤ Admin Modules:

This module performs the basic of managing the whole system. It has one login from that accepts username and password of the administrator.

➤ Instructor Modules:

User have to register first then he/she will have to login in to system then they will be able to Create course and upload course and see all the courses.

➤ User Modules:

User have to register first then he/she will have to login in to system then they will be able to See all courses.

1.3 Technology and tool

- Front End: asp.net c# MVC language

Introduction to asp.net c# MVC:

Model

This is the business layer. It helps retrieve data from the database. These are simple class files that contain the properties.

View

This component is responsible for displaying data on the screen. In MVC we use Razor Syntax. The extension of the view has “*.cshtml” instead of “.aspx” which we have used in ASP.NET in the past.

Controller

It handles input control. All the user interaction is done through Controller. A Controller is nothing but a class file that contains the methods.

- Back End: SQL server

Introduction To SQL server:

SQL Server is a relational database management system (RDBMS) developed by Microsoft. It is primarily designed and developed to compete with MySQL and Oracle database. SQL Server supports ANSI SQL, which is the standard SQL (Structured Query Language) language. However, SQL Server comes with its own implementation of the SQL language

CHAPTER – 2 PROJECT MANAGEMENT

2.1 Project Planning

I am one members in our group of mini project, At first we gathered information regarding our project like advantages, needs & other requirements, Then we prepared a power point presentation of our project, Then we prepared a project report and we started development of our project

2.2 Project Scheduling

We are following spiral model for developing our system.

Spiral model combines the advantages of top-down and bottom up concepts. Hence, we are using this model due to its following reasons:

- Our system needs continuous development. We will describe the characteristics with high priority first and then develop a prototype based on these. This prototype will be tested and desired changes will be made in the new system. This continual and steady approach will minimize the risks or failure associated with the change in the system.
- We will be developing the system in small segments that will make it easier to do cost calculations.
- The client will be involved in the development of each segment and retains control over the direction and implementation of the system.

The client's knowledge of the project grows as the project grows, so that they can interface effectively with the system.

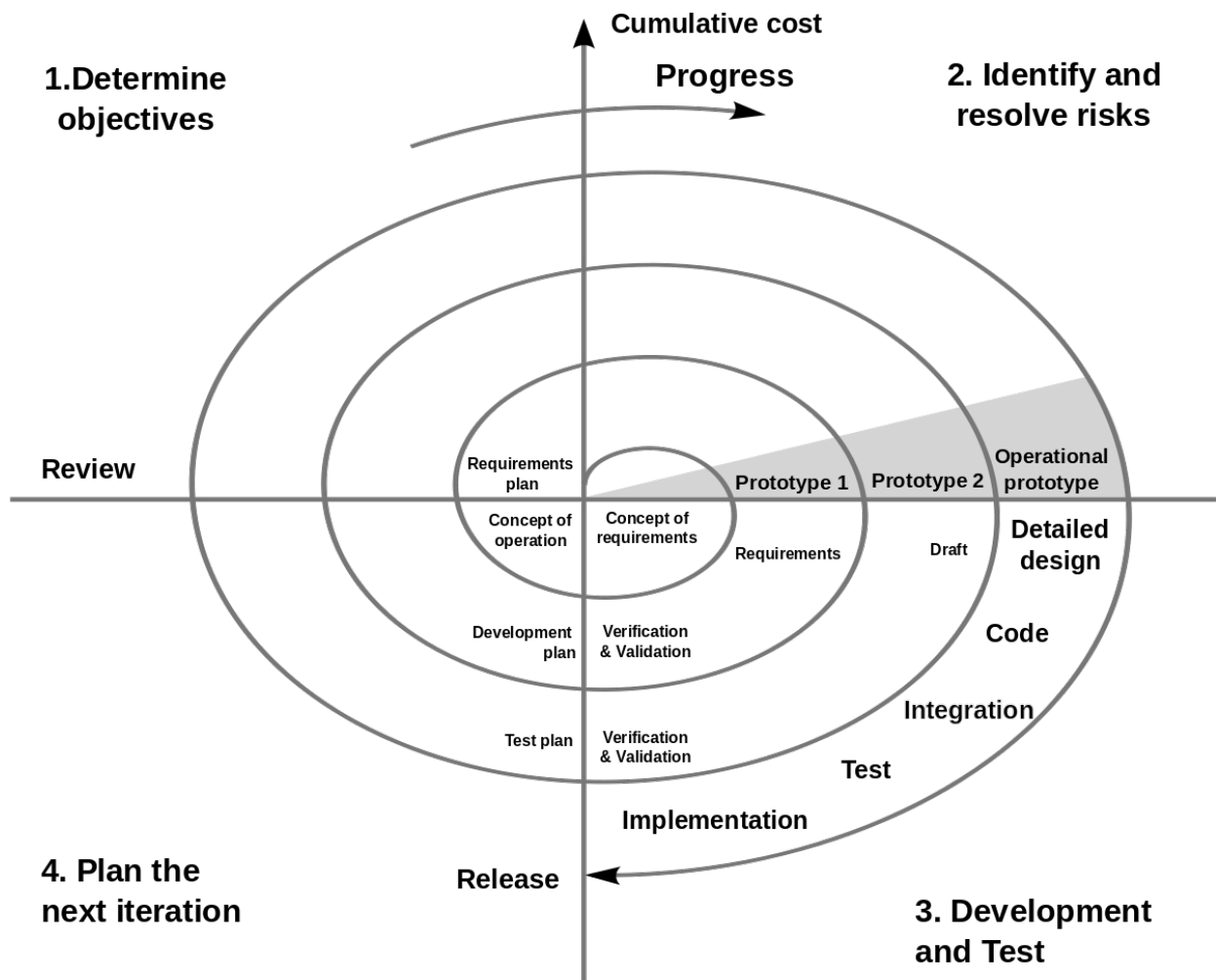

Fig 2.1 Spiral Model

CHAPTER – 3 SYSTEM REQUIREMENTS STUDY

3.1 Minimum Hardware Requirements

- 800 MHz Intel Pentium III or equivalent
- 256 MB of RAM
- 750 MB of free disk space
- Display (800 x 600 resolution or higher and 256 color mode)

3.2 Minimum Software Requirements

- Windows Operating System
- Chrome Or Other Browser
- Sql Server
- Visual studio

CHAPTER – 4 SYSTEM ANALYSIS

4.1 Study of Current System

Every work/task/records in the existing system is done on the paper manually which takes much more time. Updating the data and much more records (which is not automated) is very time consuming process. When everything is done manually there are always chances of human errors and the detection of the process is long process. Present system is not online, so there are many drawbacks for the administration and members. Members can see online

4.2 Problem and Weaknesses of Current System

- Everything is done on paper and these are highly prone to damages and require a good amount of security and space to store.
- Required Buying of goods more frequently as compared to the online system.
- Likely to have an error.

4.3 Requirements of New System

4.3.1 User Side System Requirements

Software Requirement:

- Windows Operating System
- Chrome Or Other Browser

Hardware Requirement:

- 800 MHz Intel Pentium III or equivalent
- 256 MB of RAM
- 750 MB of free disk space

CHAPTER – 5 SYSTEM DESIGN

5.1 Diagrams

The data flow diagram(DFD) is a graphical tool used for expressing system requirements in a graphical form. The DFD also known as the “bubble chart” as the purpose of clarification system requirements and identification major transformation that will become program in system design. Thus DFD can be stated as the starting point of the design phase that functionality decomposes the requirements specification down to the lowest level of details. The DFD consists of series of bubble joined by lines. The bubble represents data transformation and the lines represents the data flows in the system. A DFD describes what data flow is does not to construct a Data Flow Diagram, we use.

- Arrow: An arrow identifies the data flow in motion. It is a pipeline through which information is flow like the rectangle in the flowchart.
- Circle: A circle stands for process that converts data into information
- Open End Box: An open ended box represents a data store, data at rest or a temporary repository of data.
- Squares: A square defines a source or destination of system.

5.1.1 DFD Level 0

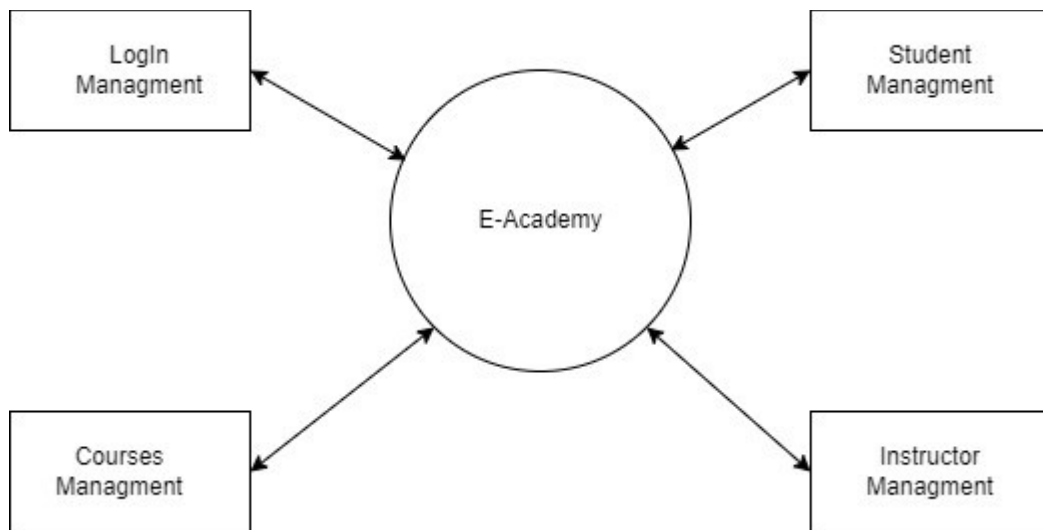

5.1.2 DFD Level 1

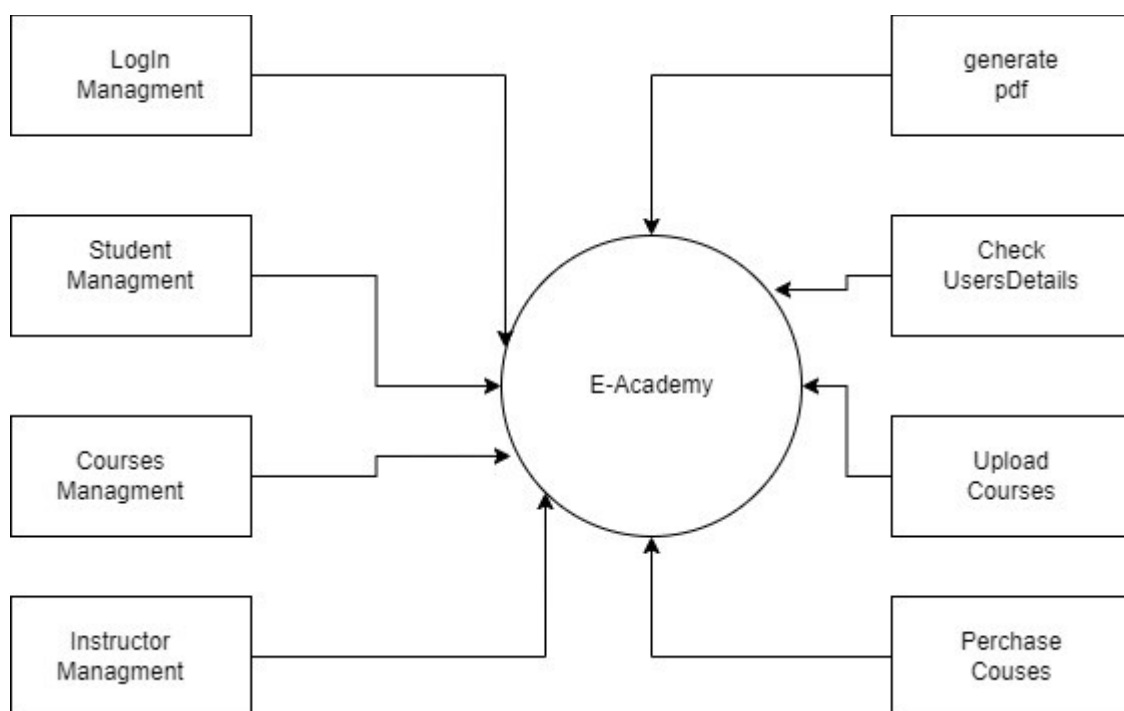

5.1.3 E-R Diagram

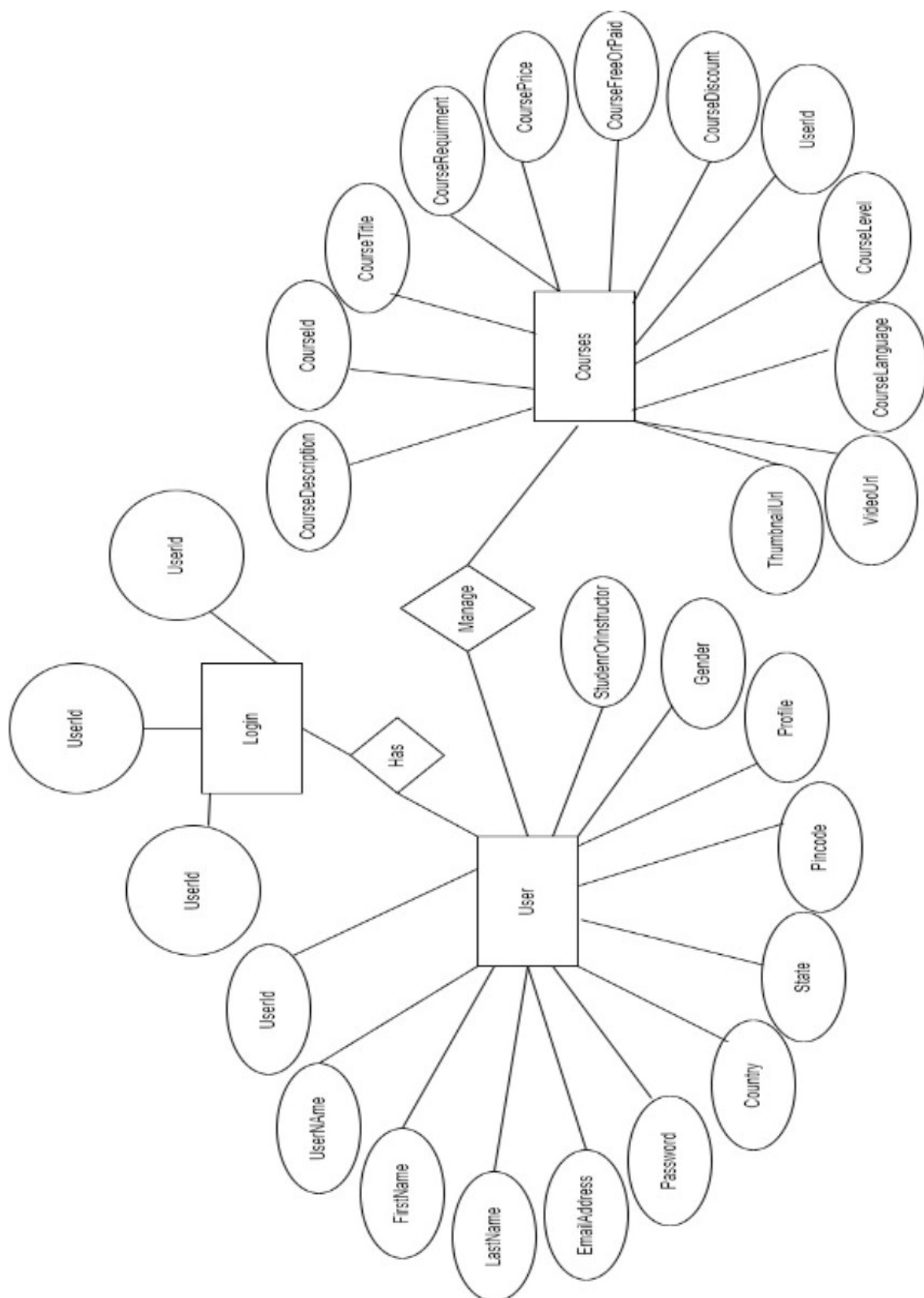

5.1.4 Use Case Diagram

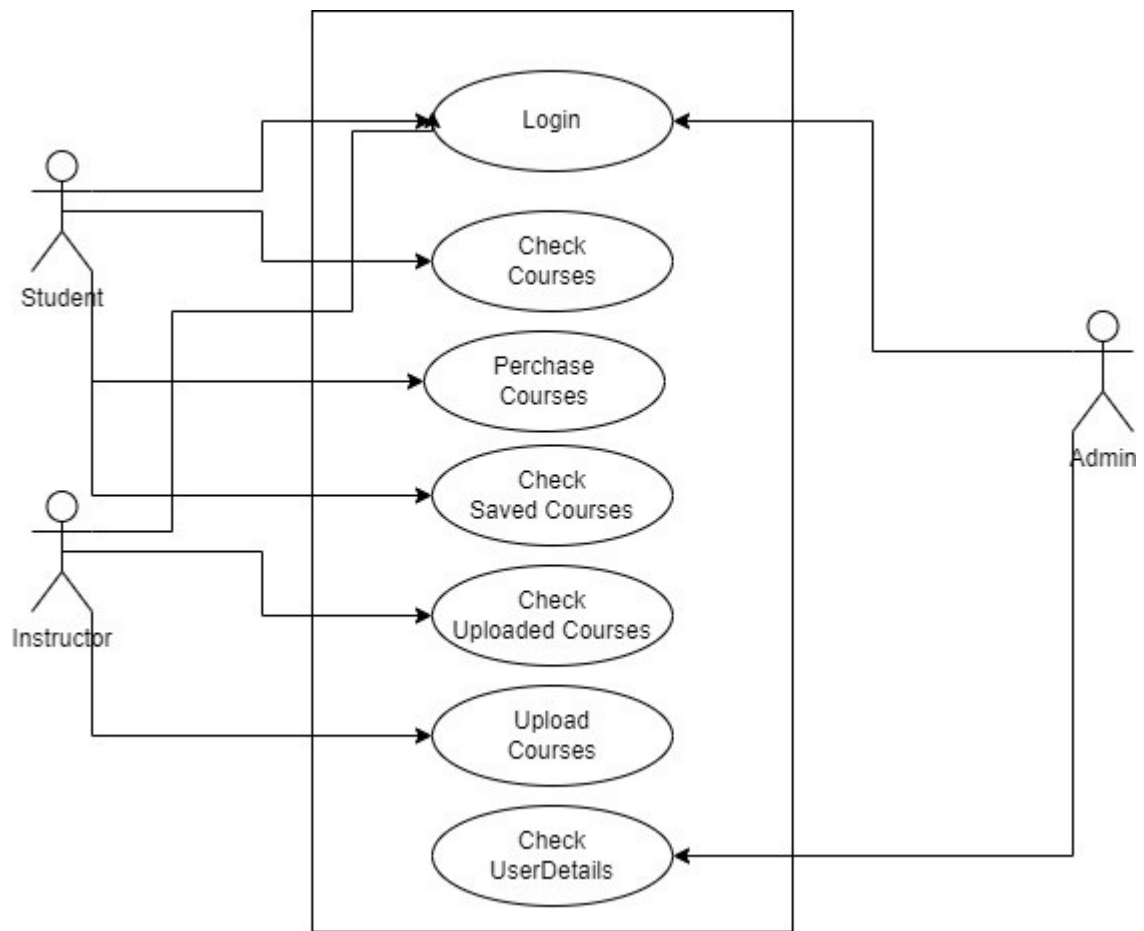

5.1.5 Flow Chart

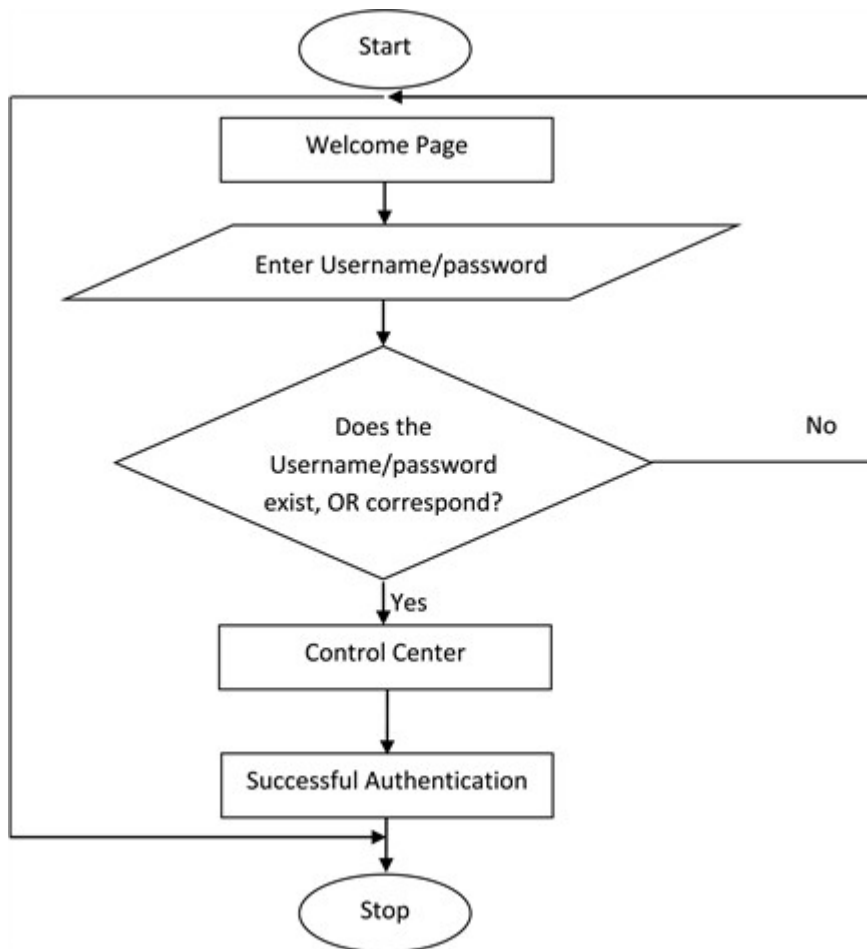

5.2 Data Dictionary

5.2.1 User Table

Name	Type	Key	Description
Id	int	Primary Key	admin and member ID for Login
Username	varchar(250)	Null	Username of admin and member
Password	varchar(250)	Null	Password for admin and member
FirstName	varchar(250)	Null	FirstName for Users
LastName	varchar(250)	Null	LastName for User
EmailId	varchar(250)	Null	Email for User
CountryId	int	Null	CountryId for Country
StateId	int	Null	StateId for state
Pincode	int	Null	Pincode for User
Address	varchar(250)	Null	Addres of User
CreateAt	datetime	Null	CreateAt for User
Gender	varchar(250)	Null	Gender of User
Profile	varchar(250)	Null	Profile for admin and member
StudentOrInstructor	varchar(250)	Null	Student and instructor

5.2.2 CourseDetails

Name	Type	Key	Description
Id	int	Primary Key	member ID for Login
CourseTitle	varchar(250)	Null	Course Title of Course
CourseDescription	varchar(250)	Null	Course description of course
CourseRequirment	varchar(250)	Null	Courses Requirment
CourseAbout	varchar(250)	Null	CourseAbout to course learn
CourseLevel	varchar(250)	Null	CourseLevel is course Level
CourseAudio	varchar(250)	Null	CourseAudio is course audio
CourseCategories	varchar(250)	Null	Course type define
CourseThumbnai	varchar(250)	Null	Define Thumbnail
CoursePrice	varchar(250)	Null	Define Course Price
CourseDiscount	varchar(250)	Null	Define Course discount
CourseRequiredEnroll	varchar(250)	Null	Define RequiredEnroll
CourseFreeOrPaid	varchar(250)	Null	Define Price

CourseVideo	varchar(250)	Null	Course video define
-------------	--------------	------	---------------------

5.2.2 UserCourse

Name	Type	Key	Description
Id	int	Primary Key	member ID for Login
CourseId	int	Null	Define CourseId
UserId	int	Null	Define UserID
PaymentId	int	Null	Define PaymentID

5.2.3 CountryMaster

Name	Type	Key	Description
Id	int	Primary Key	member ID for Login
CountryName	varchar(200)	Null	Define CountryId
CountryCode	int	Null	Define CountryCode
StateId	int	Foreign Key	Define StateId

5.2.4 StateMaster

Name	Type	Key	Description
Id	int	Primary Key	member ID for Login
StateName	varchar(200)	Null	Define StateName

CHAPTER – 6 CODE IMPLEMENTATION

6.1 Screenshots

Home Page:

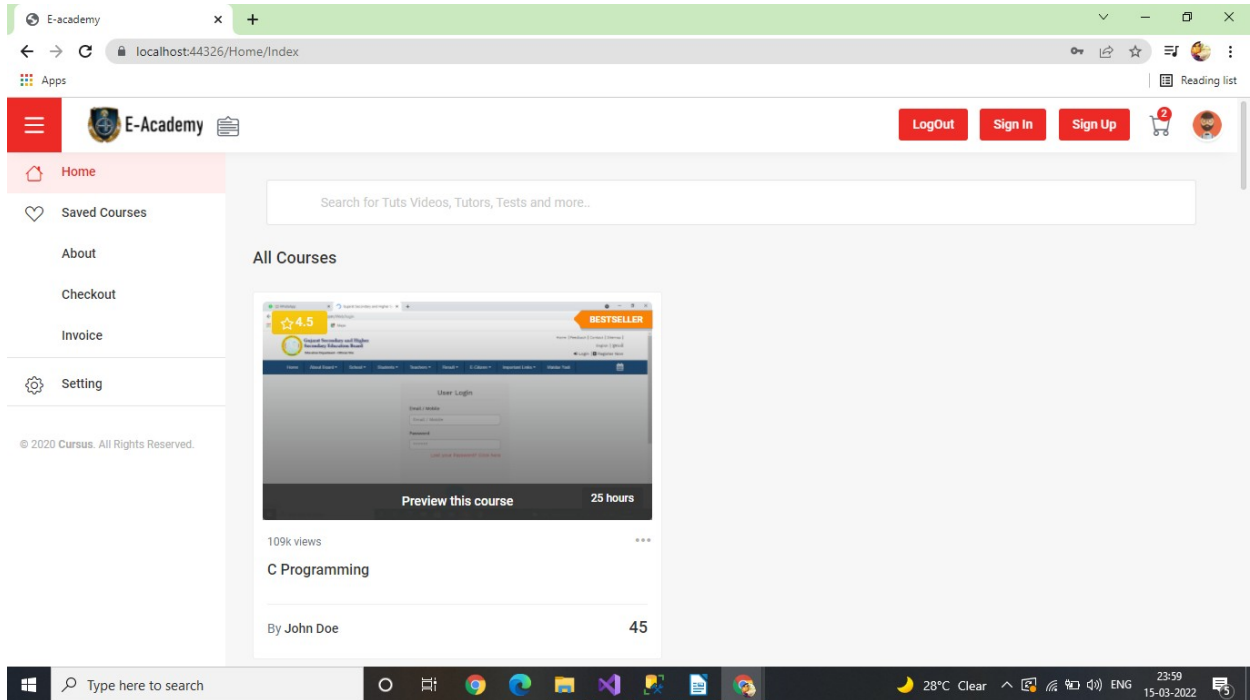

About Page:

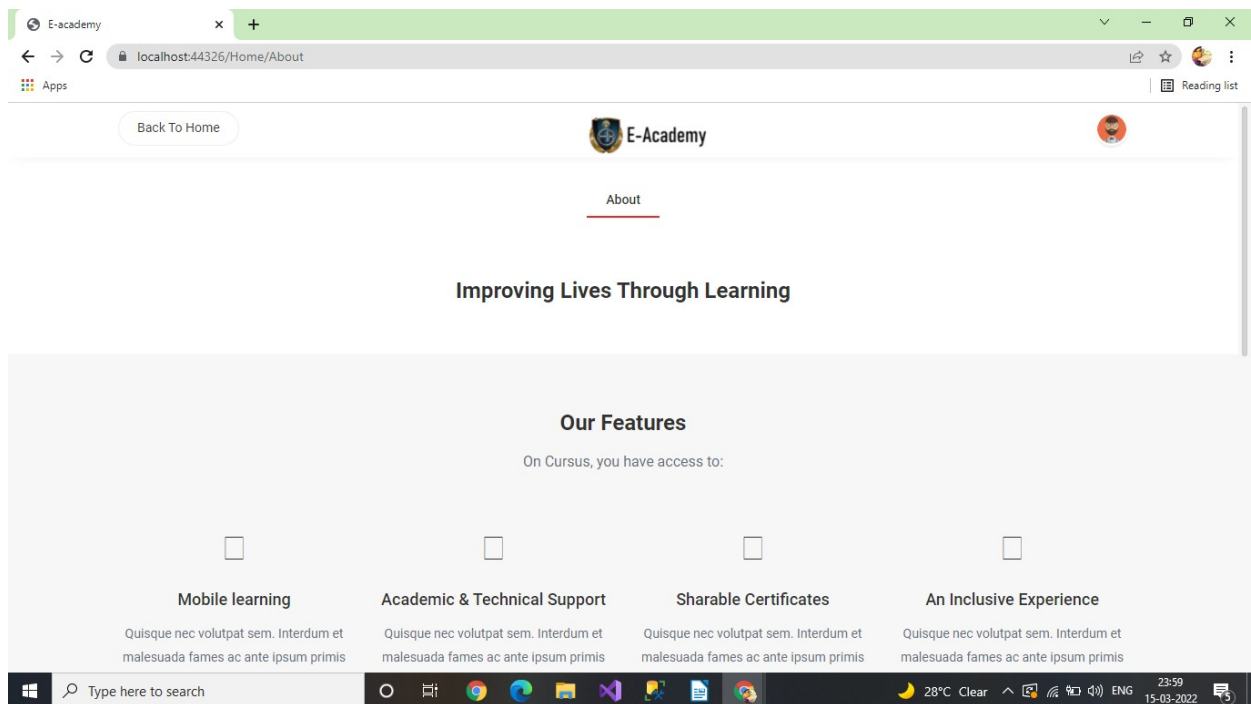

Login Page:

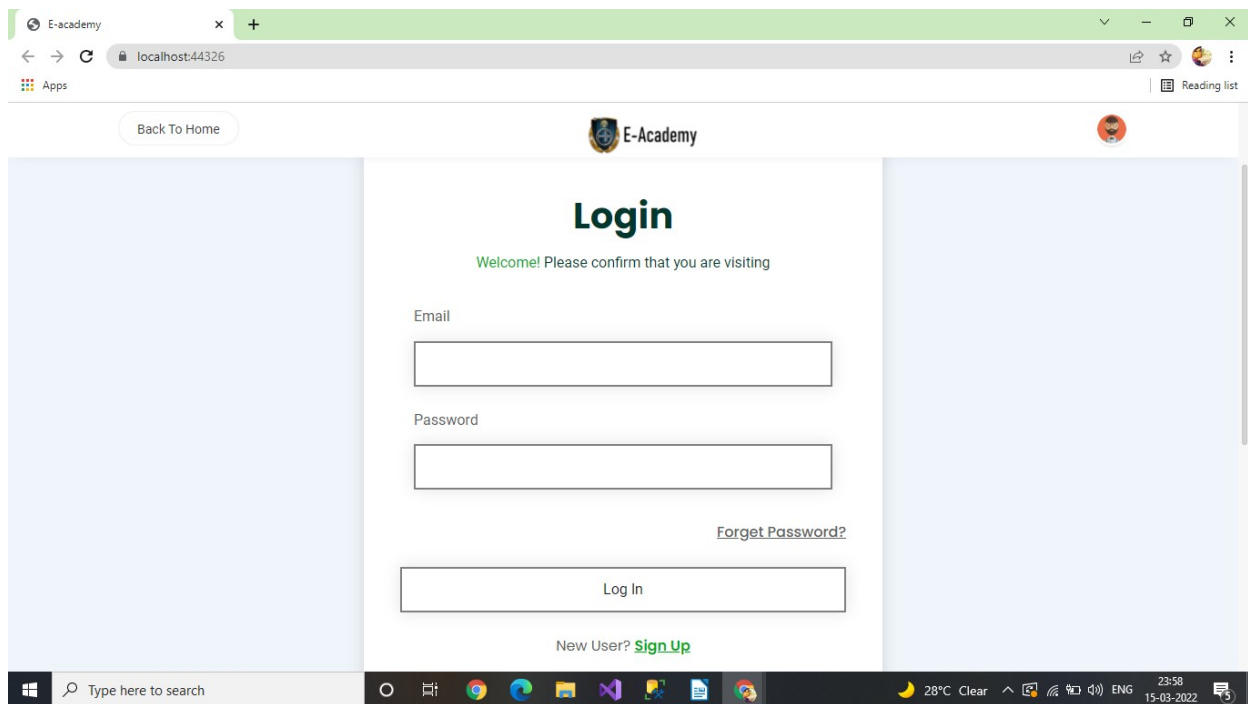

The screenshot shows a web browser window with the URL `localhost:44326`. The page features a header with a "Back To Home" button and the "E-Academy" logo. The main content area is titled "Login" and includes a welcome message: "Welcome! Please confirm that you are visiting". Below this, there are input fields for "Email" and "Password". A "Log In" button is positioned below the password field. A link for "Forget Password?" is located to the right of the password field. At the bottom of the form, there is a link for "New User? Sign Up". The browser's taskbar at the bottom shows the system tray with a date of 15-03-2022 and a time of 23:58.

Register Page:

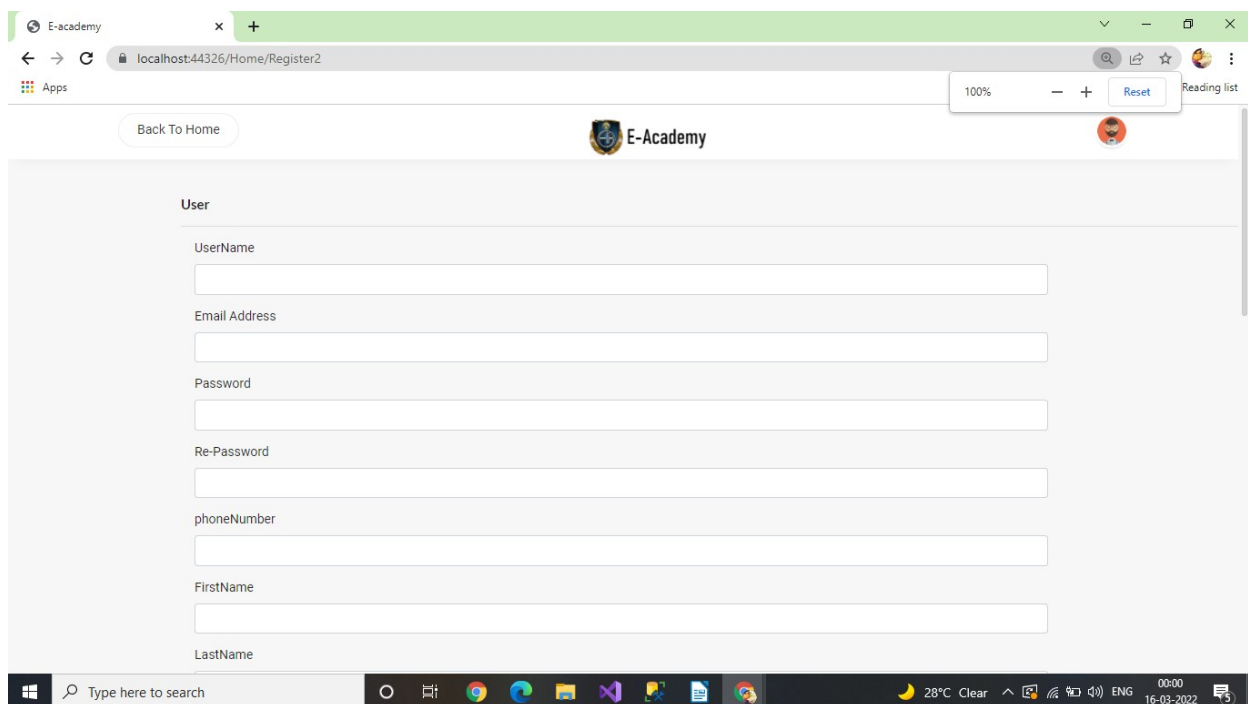

The screenshot shows a web browser window with the URL `localhost:44326/Home/Register2`. The page features a header with a "Back To Home" button and the "E-Academy" logo. The main content area is titled "User" and contains a registration form with the following fields: "UserName", "Email Address", "Password", "Re-Password", "phoneNumber", "FirstName", and "LastName". A "Reset" button is visible in the top right corner of the browser window. The browser's taskbar at the bottom shows the system tray with a date of 16-03-2022 and a time of 00:00.

Add CourseDetails Page:

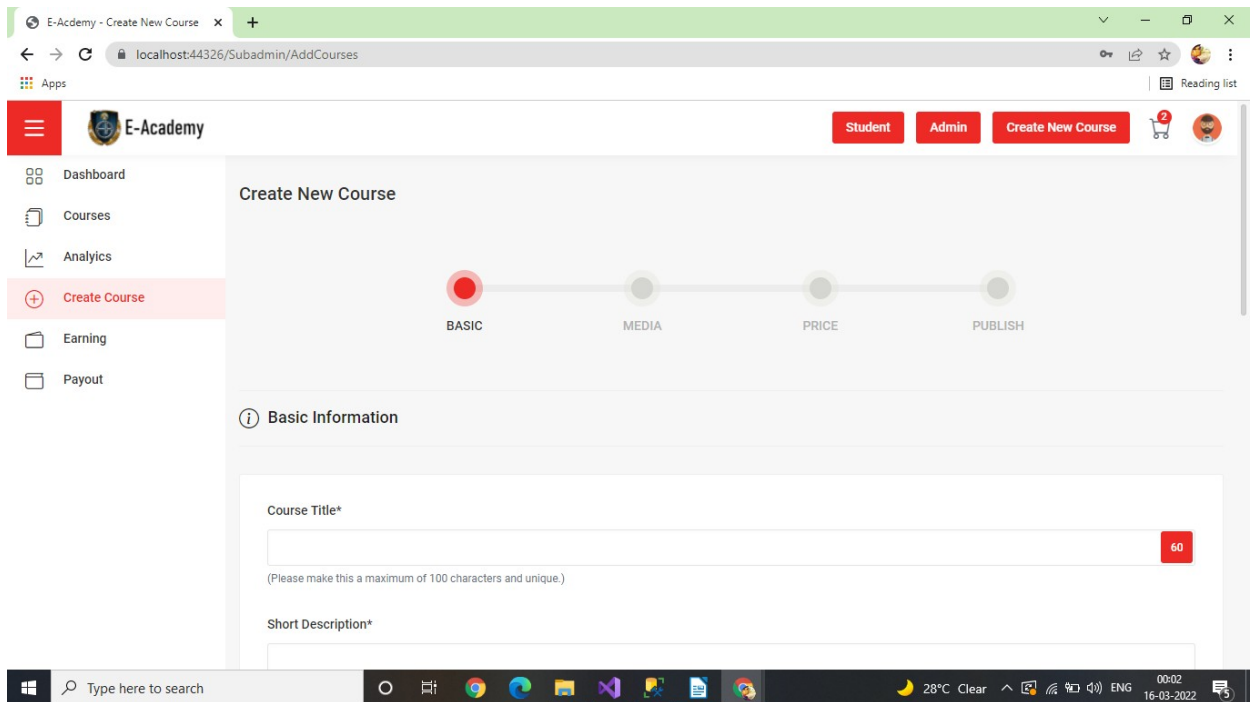

Add Video Page:

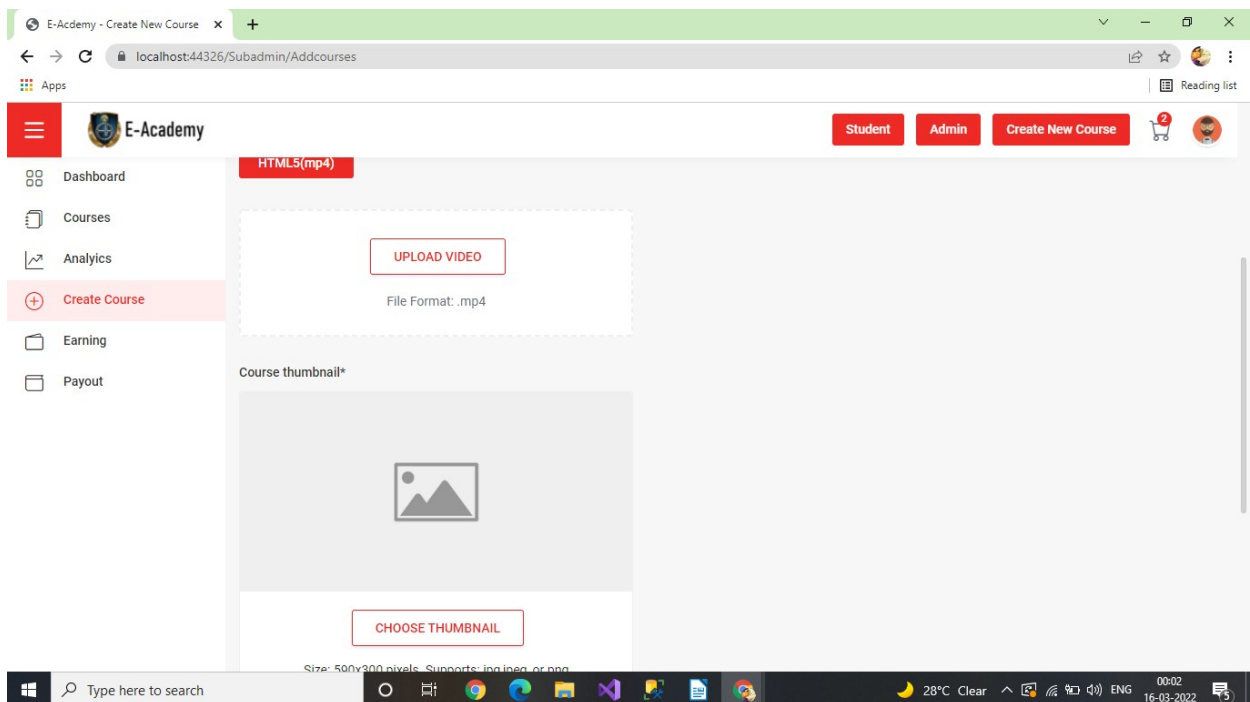

Final Submit Course Page:

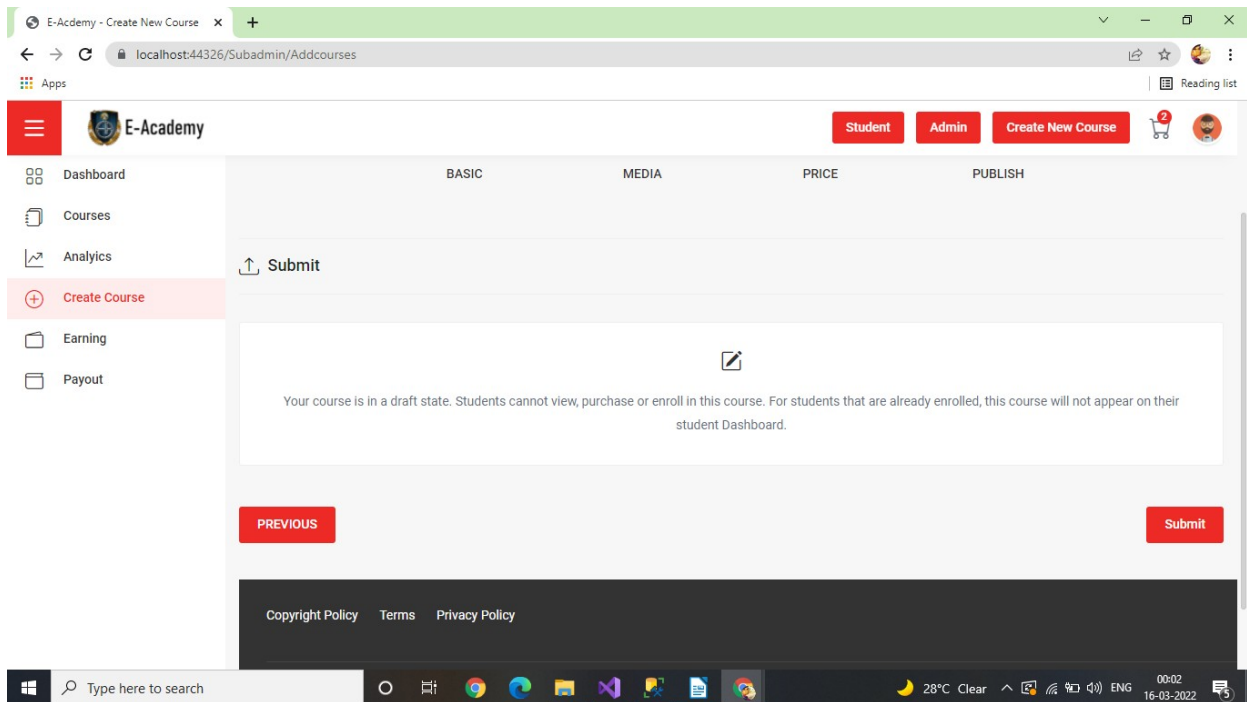

Course Price Add Page:

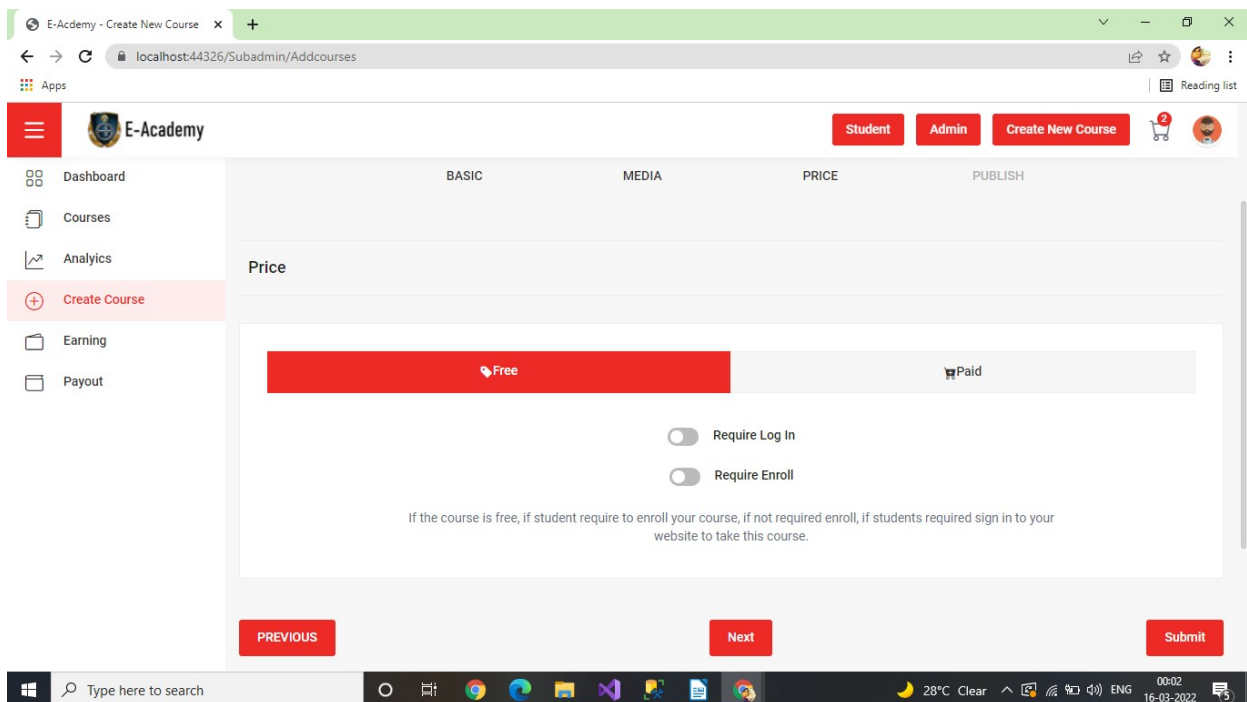

Instructor Courses Page:

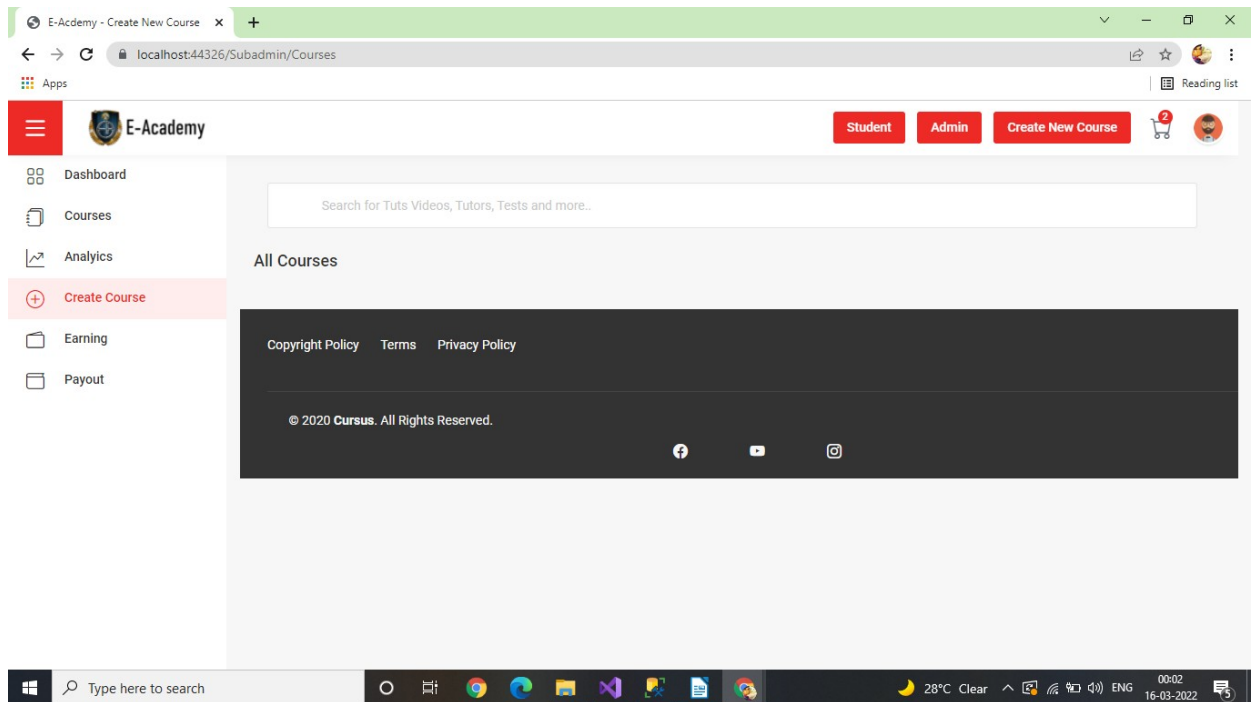

Course Detail Page:

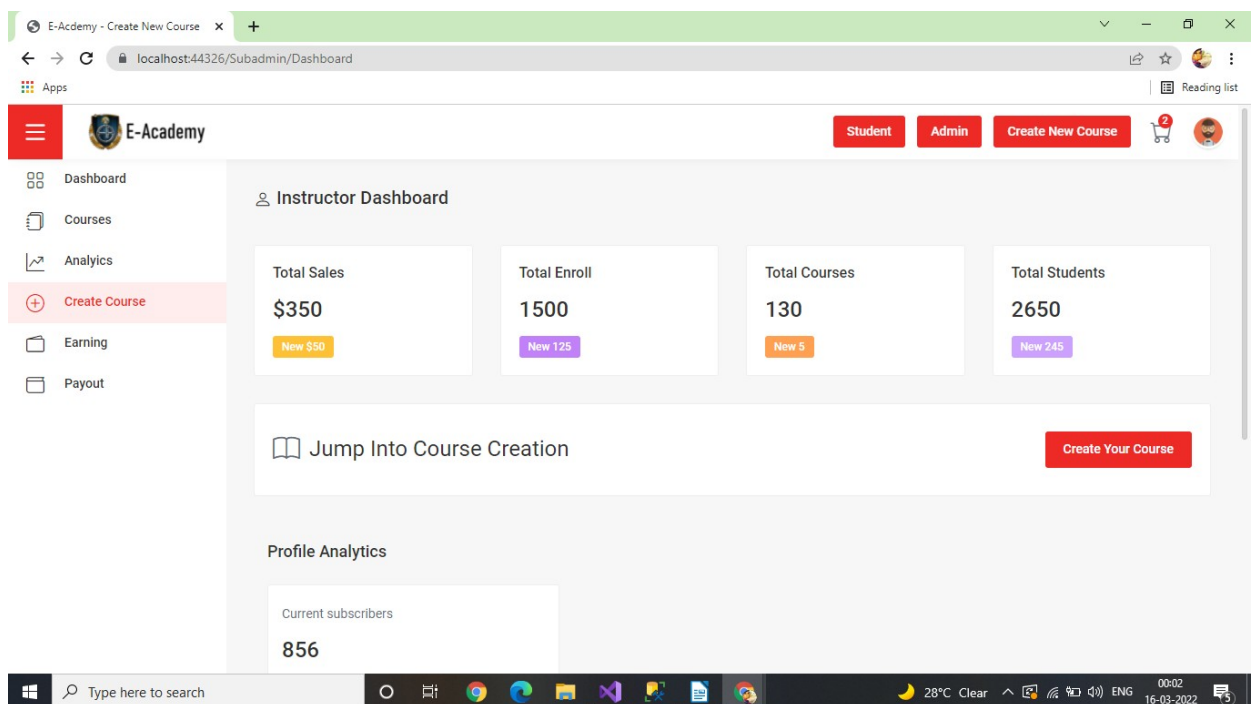

User Detail Page:

The screenshot shows the E-Academy user detail page. The browser address bar indicates the URL is localhost:44326/Admin/ViewDetails. The page header includes the E-Academy logo, a 'LogOut' button, and a shopping cart icon with a '2' notification. The main content is a table with the following columns: UserName, FirstName, LastName, EmailId, Address, PhoneNumber, City, CreatedBy, CreateAt, UpdatedBy, UpdatedAt, and Gender. The table contains five rows of user data.

UserName	FirstName	LastName	EmailId	Address	PhoneNumber	City	CreatedBy	CreateAt	UpdatedBy	UpdatedAt	Gender
avesh	mathakiya	mahamadavesh	mahamadavesh786@gmail.com	at. vaghasiya ta.wankaner dist. morbi pin.363621	9106631033	vaghasiya		13-03-2022 19:26:35			M
avesh	avesh	mahamadavesh	mahamadavesh786@gmail.com	at. vaghasiya ta.wankaner dist. morbi pin.363621	9106631033	vaghasiya		13-03-2022 21:23:35			1
sakir	avesh	mathakiya	aveshmathakiya786@gmail.com	at.vaghasiya	9638632569	wankaner		13-03-2022 21:44:26			1
avesh	avesh	mathakiya	aveshmathakiya786@gmail.com	at.vaghasiya ta.wankaner dist.morbi	9106631033	wankaner		13-03-2022 22:26:43			1
avesh	mathakiya	avesh	aveshmathakiya786@gmail.com	at.vaghasiya	8140339146	wankaner		13-03-2022 22:35:53			M

Student Edit Profile:

The screenshot shows the E-Academy student edit profile page. The browser address bar indicates the URL is localhost:44326/Home/Student_Edit. The page header includes the E-Academy logo and a shopping cart icon. The left sidebar contains navigation links: Home, Saved Courses, About, Checkout, Invoice, and Setting. The main content area is titled 'Edit Details' and contains a form with the following fields: UserName (alfej), FirstName (alfej), LastName (mathakiya), Email (alfejmathakiya10@gmail.com), Address (vaghasiya), PhoneNumber (9874563210), and City (wankaner). A green 'Save' button is located at the bottom of the form.

Instructor Edit Profile:

The screenshot displays a web browser window with the URL `localhost:44326/Subadmin/Instructor_Edit`. The application header includes the 'E-Academy' logo and a 'Create New Course' button. A sidebar on the left contains navigation options: 'Dashboard', 'Courses', and 'Create Course' (highlighted in red). The main content area is titled 'Edit Details' and contains a form with the following fields:

- UserName:
- FirstName:
- LastName:
- Email:
- Address:
- PhoneNumber:
- City:

A green 'Save' button is located at the bottom of the form. The Windows taskbar at the bottom shows the search bar, taskbar icons, and system tray information including '34°C Sunny' and the date '27-03-2022'.

CHAPTER – 7 LIMITATIONS AND FUTURE ENHANCEMENT

7.1 Advantages and Disadvantages

Advantages:

1. Secured data storage for authority end
2. Provide better graphical interface
3. Accurate system without any data redundancy.
4. Computation can be helpful as mean of saving time and money

Disadvantages:

1. Any system Error
2. Time to time Maintenance.

CHAPTER – 8 CONCLUSION

8. Conclusion

E-learning is becoming increasingly prominent in tertiary education. All available evidence points toward growing enrolments and provision albeit from a low starting point. However, after the hype of the new economy, growing disenchantment with e-learning has replaced over-enthusiasm. Failures of e-learning operations have, at least temporarily, overshadowed the prospects of widened and flexible access to tertiary education, pedagogic innovation, and decreased cost that was once embodied by e-learning. So where do we stand after the end of the hype of the new economy? What are the next steps to move e-learning forward in tertiary education and to reap its potential benefits?

CHAPTER – 9 REFERENCES

References

- w3school.com
- www.google.com
- Youtube.com