

# Knowledge Management in Higher Education Institutions

## Volume - II



### **Editors:**

Dr. K.S. Shivraj

Dr. Phayung Meesad

Dr. Akhilesh Kumar Sharma

# Knowledge Management in Higher Education Institutions

## Volume - II

International Conference on  
**Knowledge Management in Higher Education Institutions**  
(ICKHI 2024)  
30-31 January 2024



Organized by  
**Central Library**  
**Manipal University Jaipur, India**



Jointly with  
**University Library**  
**King Mongkut's University of Technology,**  
**North Bangkok, Thailand**

Editors  
**Dr. K.S. Shivraj**  
**Dr. Phayung Meesad**  
**Dr. Akhilesh Kumar Sharma**



**MANIPAL UNIVERSITY**  
**JAIPUR**

**Jaipur, Rajasthan**

First Edition Published in 2024 by  
**Manipal University Jaipur**  
Dehmi Kalan, Jaipur -303007, Rajasthan, India  
Ph: +91-141-3999100 Ext. 179  
www.jaipur.manipal.edu  
e-mail: karamadai.shivraj@jaipur.manipal.edu

The responsibility for the fact or opinion expressed in the papers are entirely of the authors. Neither the University nor the publisher are responsible for the same.

©Reserved

**Knowledge Management in Higher Education Institutions**  
Volume-II

by  
Dr. K.S. Shivraj  
Dr. Phayung Meesad  
Dr. Akhilesh Kumar Sharma

**ISBN: 978-81-952757-9-3**

Price: Rs.1,000/-

Laser Type Setting  
Dr.K.S.Shivraj

Printed in India at  
Manipal University Jaipur

# PREFACE

It is with immense pleasure and profound pride that we present the conference proceedings of the 3rd Edition of the International Conference on Knowledge Management in Higher Education Institutions (ICKHI 2024), held on 30-31 January 2024. This collection stands as a testament to the collaborative efforts and scholarly contributions of individuals from esteemed institutions worldwide who converged to delve into the dynamic realm of knowledge management in higher education.

Organized by the Central Library of Manipal University in collaboration with King Mongkut's University of Technology North Bangkok, Thailand, the conference served as a vibrant platform for scholars, professionals, and researchers to engage in stimulating exchanges of ideas and insights. It was a forum where diverse perspectives converged, fostering rich discussions on the pivotal theme of knowledge management in higher education.

We are delighted to announce that we received a total of 140 papers from professionals and research scholars across the globe. Out of these submissions, 90 papers were thoughtfully selected for inclusion in the conference proceeding volumes, covering a broad spectrum of topics encapsulated within eight distinct categories.

1. Knowledge Management in Information Centers (KM)
2. ICT Enabled Library Services (IT)
3. Open-Source Software & Resources in Higher Education (OS)
4. Digital / Virtual Libraries in Academic Institutions (DL)
5. Mobile and Semantic Web Technologies in Libraries (MS)
6. Copy Right Issues and Total Quality Management (CR)
7. E- Learning / Virtual Learning (EL)
8. LIS Education & Best Practices in Libraries (LS)

As we extend our sincere gratitude to Dr. Gopalakrishna Prabhu, President of Manipal University Jaipur, Dr. Jawahar Mal Jangir, Pro President, and Dr. Nitu Bhatnagar, Registrar of Manipal University Jaipur, for graciously affording us the opportunity to organize this impactful conference, we also extend our heartfelt appreciation to Prof. Dr. Teravuti Boonyasopon, Chairman, King Mongkut's University of Technology North Bangkok, Thailand for their invaluable support in jointly conducting this event.

Furthermore, we express our profound gratitude to the members of the International Advisory Committee, National Advisory Committee, and the Organizing Committee, as well as the dedicated staff of Manipal University Jaipur, India, and the King Mongkut's University of Technology North Bangkok, Thailand for their unwavering support and assistance throughout the planning and execution phases of the conference.

Last but certainly not least, we extend our deepest appreciation to all the authors whose scholarly contributions have enriched the discourse on knowledge management in higher

education. Your dedication has not only advanced the field but has also contributed significantly to inspiring further research and innovation.

It is our sincere hope that this compilation of papers will serve as a valuable resource, igniting new avenues of inquiry and guiding the endeavours of scholars, practitioners, and policymakers in the field of higher education and knowledge management.

Dr. K.S. Shivraj  
Dr. Phayung Meesad  
Dr. Akhilesh Kumar Sharma



## Message



I am delighted to learn that the Central Library of Manipal University Jaipur, in collaboration with King Mongkut's University of Technology North Bangkok (KMUTNB), Thailand, is organizing the third edition of the Online International Conference on Knowledge Management in Higher Education Institutions (ICKHI-2024) on January 30<sup>th</sup>-31<sup>st</sup>, 2024.

In higher education institutions, knowledge management (KM) plays a vital role in leveraging intellectual assets for improved teaching, research, and administrative processes. KM initiatives in academia aim to capture, organize, and disseminate both explicit and tacit knowledge among faculty, staff, and students. These efforts facilitate collaborative research, interdisciplinary cooperation, and the development of innovative educational practices. KM strategies often involve the creation of digital repositories, learning management systems, and academic networks to store and share scholarly resources. By harnessing institutional knowledge, universities can enhance curriculum development, student learning outcomes, and faculty professional development.

It is inspiring to note that more than 130 research papers have been received from academicians from all over India and various other countries. With such diverse and substantial participation, I am confident that this conference will foster a knowledge-driven environment, offering a shared platform for researchers, technologists, and scholars to exchange ideas and engage in discussions on emerging trends in the field. It is anticipated that the conversations and insights from the conference will spur innovations and ensure that everyone remains informed about the latest technological developments.

On behalf of Manipal University Jaipur, I extend a heartfelt welcome to all participants of ICKHI-2024. I extend my sincere congratulations to the Central Library and the organizing committee for their dedicated efforts in orchestrating this conference in a fitting manner.

I wish the conference great success.

**Dr. G K Prabhu**  
President  
Manipal University Jaipur



## Message



I am pleased to note that the Central Library of Manipal University Jaipur, in collaboration with King Mongkut's University of Technology North Bangkok (KMUTNB), Thailand, is hosting the third edition of the Online International Conference on Knowledge Management in Higher Education Institutions (ICKHI-2024) on January 30<sup>th</sup>-31<sup>st</sup>, 2024.

The importance of fostering knowledge management in the workforce is increasingly recognized, particularly with the rapid advancements in higher education. One of the major challenges for academicians is to apply their expertise across various realms of knowledge management and engage in interdisciplinary research. It is imperative to perceive this challenge as an opportunity for progress in higher education. Another significant challenge lies in identifying how these techniques can assist young researchers in enriching their knowledge and developing innovative applications in fields such as Science and Humanity, Social Sciences, Library Sciences, and other Allied Sciences.

I am confident that this conference will offer valuable insights into the diverse domains of Science and Humanity. It will serve as a platform for presenting the latest developments and applications in the fields of Knowledge Management and Innovation across various disciplines, including Engineering, Health Sciences, Social Sciences, and other related fields. The intellectually stimulating interactions and exchange of productive ideas are expected to benefit all participants.

I extend my congratulations to the Central Library on undertaking this endeavour and offer my best wishes for the success of the conference.

**Commodore (Dr.) Jawahar M Jangir**  
Pro-President  
Manipal University Jaipur







## Message



I am very happy to extend my warmest greetings to each of you, as we embark on an exciting journey towards the 3rd Edition of Online International Conference on Knowledge Management in Higher Education Institutions (ICKHI 2024), hosted by the Central Library of Manipal University Jaipur in collaboration with King Mongkut's University of Technology North Bangkok, Thailand on 30<sup>th</sup> to 31<sup>st</sup> January 2024. This conference promises to be a forum brimming with innovative ideas, insightful discussions, and valuable networking opportunities.

In the dynamic realm of Higher Education Institutions (HEIs), the role of knowledge management transcends mere information dissemination; it becomes the cornerstone of innovation and progress. As educational paradigms shift and technologies advance, the need to adeptly manage and leverage knowledge resources intensifies. HEIs must embrace a culture of continuous learning and adaptation to remain relevant in an ever-changing world.

Effective knowledge management practices not only enhance teaching and learning experiences but also empower academic communities to tackle complex challenges with agility and creativity. By fostering interdisciplinary collaboration and fostering a spirit of inquiry, HEIs can cultivate a fertile ground for groundbreaking research and holistic development.

I extend my heartfelt gratitude to the organizing committee, associates, and participants for their unwavering commitment to making ICKHI 2024 a resounding success. Your dedication and enthusiasm exemplify the spirit of academic excellence and international cooperation that defines Manipal University Jaipur and King Mongkut's University of Technology North Bangkok, Thailand.

Warm Regards,

**Dr. Nitu Bhatnagar**  
Registrar  
Manipal University Jaipur



## Contents

	Page Nos.
1 Library Kiosk: A Self-Service Tool for Libraries to Deliver Services to Patrons <i>Avinash Lande and Dr. Archana Arun Vanikar Kulkarni</i>	1
2 Influence of ICT on Vocational Interests of GCE A/L Students in Kurunegala District, Sri Lanka <i>K.K.A.H. Kumarasinghe and Y.H.P.S.S. Pathirathna</i>	6
3 Role and Impact of Blockchain with Special Reference to Academic Libraries <i>Rikta Turul and Diprit Turul</i>	12
4 Artificial Intelligence in Academic Libraries <i>S. Kamalaveni and Dr. G. Ulaganathan</i>	18
5 Implementation of Internet of Things in Academic Libraries <i>S. Kamalaveni and Dr. G. Ulaganathan</i>	24
6 The Mobile Knowledge Exchange: Exploring Student Attitudes and Perceptions of Mobile-Mediated Knowledge Sharing: A Study at St. Joseph Engineering College, Mangalore, Karnataka, India <i>Dr. Dayanandappa Kori</i>	31
7 Evaluation of Library Circulation Services in Engineering Colleges in Hyderabad and Ranga Reddy Districts: A Study <i>Dr. Kumara Swamy Reddy Kothapati</i>	38
8 Anuvadini AI Portal: AICTE's Revolutionary Approach to Enhancing Language Accessibility and Communication in Libraries and Academic Engagements <i>M. Prakash, J. Arumugam and M. Sathish Kumar</i>	45
9 The Role of Forensic Accounting and Management Control Systems as Tools in Combating Cyber Fraud in FinTech Services <i>M. Leelavathi, R. Gowtham and Dr. A. N. Radhika</i>	53
10 Revolutionizing Higher Education: Unleashing Knowledge Management and Artificial Intelligence in Library Services <i>Parre Ramya</i>	63

11	Applications of Big Data Tools in Libraries <i>J. Arumugam, R. Abraham Dinesh and S. Meganathan</i>	70
12	Transforming Libraries with Artificial Intelligence: Innovations and Impact <i>A. Kumarachelvan and Dr. G. Ulaganathan</i>	76
13	Application of Big Data in Libraries: A Study <i>S. Paramasivam and Dr. G. Ulaganathan</i>	81
14	An Overview of the Operational Impact of Artificial Intelligence in Libraries <i>Dr. P. Krishnakumar</i>	85
15	Big Data Analytics and Applications in Libraries <i>P. Ramu Naik</i>	91
16	Usage Methods of ICT Resources and Services by Users at Sri Aurobindo College Library, Bangalore: A Study <i>M. C. Durga Parsad</i>	98
17	Revolutionizing Library Services: A Comprehensive Study of AI Tools for Enhancing Library Services <i>Hafijull Mondal and Mrinmoy Paul, Sajal Kumar Mondal and Chand Sultana Khatun</i>	104
18	Proliferation of Literature on Artificial Intelligence in India: A Scientometric Analysis <i>Rajeev Kumar Attri and Dr. Ashok Kumar Upadhyay</i>	116
19	Issues and Challenges of Library Automation in College Libraries of Asansol: A Study <i>Biswajit Bhattacharya</i>	123
20	Emerging Trends and Services in Libraries: A Futuristic Approach <i>Anil Kumar Mishra, Vrij Kishor Mishra and Dr. Zulfikar Ahmad Khan</i>	128
21	Investigating the Influence and Obstacles of AI-Driven Chatbots in Educational Settings: Insights for 2023 <i>Zohaib Hassan Sain</i>	137
22	Application of an IoT-Enabled Solar-Powered Microcontroller System for Preservation of Archived Materials in Libraries <i>Mohan Teja Mattigiri, Nilufer Tamatgar and Dr. Mahabaleshwara Rao</i>	141

23	Revolutionizing Libraries with RFID, Biometric Gates and Self-Service Kiosks <i>Renald Moses, Rohini Manikandan and Anneruth</i>	151
24	Roles of Information and Communication Technology (ICT) in Knowledge Management (KM) at Nigerian Higher Institutions <i>Muhammad Muhammad Suleiman, Abubakar Ukashatu, Bilkisu Gambo Danmuchikwali, Yusuf Auwalu and Ali Muhammad Sulaiman</i>	158
25	The Strategy of Academic Libraries for Promoting Open Access Resources in Electronic Media: A Study of Management Institutes in the Mumbai Metropolitan Area <i>Sangeeta Kamble and Dr. Mayank Trivedi</i>	164
26	Open Source Library Management Software: A Comparative Study of KOHA and Evergreen <i>Rinku and Dr. DharamVir Singh</i>	170
27	A Study on the Design and Implementation of SLIMS at Kongu SRV International School Library <i>S. Vijay and S. Gunaseelan</i>	177
28	The Use of Open-Source Software by Library Users in Private Universities in Ghana <i>Silas Adjei</i>	188
29	Data Visualization Tools and Techniques: An Overview <i>Dr. Pronobi Porel and Dr. Swapan Khan</i>	196
30	Leveraging Open-Source Systems and Metadata Standards for Strategic E-Book Analytics in Libraries <i>Phayung Meesad and Jeerapol Kumkeam</i>	204
31	The Importance of Open Source Tools for Research <i>A. P. Ramesh, Dr. Purushothama Gowda and Dr. P. Pushpa</i>	216
32	Use of Open Source Software for Web-Based Subject Guides in an Academic Library <i>Dr. S. Yesan and C. Siva Kumar</i>	220
33	Awareness and Perception of Plagiarism among Post-Graduate Physical Sciences Students at North-Eastern Hill University <i>Bansharai Wartde and Jiarlimon Khongtim</i>	227

34	Exploring Open Source in Libraries: A Comprehensive Literature Review <i>Renald Moses, Rohini Manikandan and Anneruth</i>	235
35	Assessing Electronic Resource Utilization Among Undergraduate, Graduate and Faculty Users in Engineering College Libraries of Coimbatore District <i>K. Subramanian and Dr. G. Ulaganathan</i>	239
36	Intellectual Repositories in Institutions of Higher Learning with Special Reference to D-Space and E-Prints <i>Sanjay Kumar Jha and Dr. Ashok Kumar Upadhyay</i>	248
37	The Emergence of Information Civilization: The Role of Universities, Information Elites, and Consortia in Knowledge Sharing <i>Vineeta Chauhan</i>	256
38	A Study on the Use of Digital Libraries by Engineering Students: A Case Study <i>S. Rajasekaran, Dr. M. Mani and Dr. C. Pandeeswaran</i>	264
39	Navigating the Digital Landscape: A Study on the Effectiveness of E-Resources <i>T. S. Somashekhar, S. Shamala and Dr. Vitthal Bagalkoti</i>	270
40	Utilizing Institutional Repositories and Content Management Systems for Information Preservation and Dissemination: A Focus on D-Space and Drupal <i>V. Bharathkumar</i>	276
41	Digital Information Literacy Among Selected Engineering Students: A Study <i>S. Sheeba and Dr. S. Vijayakumar</i>	282
42	Web Presence of Library Consortia: A Webometric Study <i>Richa Arya and Aman Verma</i>	288
43	Analysis of Digital Library Information Services: A Comprehensive Review <i>Dr. P. Krishnamoorthy</i>	295
44	Exploring Digital Information Literacy Skills Among Library Users <i>S. Shamala, Somashekhar and Dr. Vitthal Bagalkoti</i>	302

45	Digital Preservation of Knowledge: Issues and Challenges <i>Sakhawat Hussain and Dr. Rajesh Kumar</i>	309
46	Knowledge Sharing and Dissemination in Educational Institutions: Practices and Comparative Insights Between Public and Private Sectors <i>Dr. Sharon Valarmathi</i>	315
47	A Study on Activities and Services of the National Digital Library of India: Perspectives on Digital Libraries <i>Kakoli Goswami and Pranjit Kalita</i>	321
48	Utilization of Electronic Databases by Users of Doon University <i>Shrikrishan and Dr. Dhiraj Sharma</i>	327
49	Hyflex Libraries: Bridging the Gap Between On-Campus and Online Resources <i>Dr. Sudhi S. Vijayan, Dr. V. R. Arunkumar and Dr. V. R. Renjith</i>	335
50	Digital/Virtual Libraries in Academic Institutions (DL): Smart Libraries <i>M. C. Yeswanth and Dr. K. Vijaykumar</i>	341
51	Usage and Challenges of Citation Databases in Research and Academics <i>Praveen Kapoor and Dr. Ashok Kumar Upadhyay</i>	344
52	Empowering Women through E-Resources: A Comprehensive Review <i>Susan Babu and Dr. A. Senthamilselvi</i>	355
53	Digital Privacy in University Libraries in Kerala <i>Aparna Nair and Dr. B. Mini Devi</i>	361
54	Collection Management of Electronic Information Resources for Academic Libraries <i>H. G. Srikanth and Dr. Malatesh N. Akki</i>	371
55	Connected Campuses: The Role of Networking in Private University Education <i>Sanjiv K. Sain and Dr. Rajesh Kumar Singh</i>	377
56	Information Literacy and User Education in Academic Libraries <i>Dr. S. Rajunaik</i>	384
57	Unveiling the Power of E-Content: Exploring Student Behavioral Change <i>Dr. Priyanka Suchak, Kausumi Nanavati Mehta and Yash Deliwala</i>	390



58	Advancements in Advanced Driver Assistance System Research: Insights from Indian Contributions with Special Reference to Scopus (2008-2023) <i>M. Sathish Kumar and Dr. L. Santhi</i>	396
59	Research Support Services: A State-of-the-Art Review <i>Jyoti Sharma and Dr. Deepmala</i>	404
60	Ethics in Research: Concepts, Needs, and Issues in Research Practices <i>Shabnam and Prof. Savita Kaushal</i>	413

# Library Kiosk: A Self-Service Tool for Libraries to Deliver Services to Patrons

**Avinash Lande<sup>1</sup> and Dr. Archana Arun Vanikar Kulkarni<sup>2</sup>**

<sup>1</sup>Librarian, D.Y. Patil College of Engineering, Akurdi, Pune, Maharashtra, India

<sup>2</sup>Librarian, B.P. Arts, S.M.A.Sc. and K.K.C. Commerce College, Chalisgaon, India

E-mail: lande.avinash2@gmail.com, archanasandeshkulkarni@rediffmail.com

## **Abstract**

*As we all know that we are living in 21<sup>st</sup> century and we must adopt changes which make up the requirement of the present era. Internet and information technology impacts on every field. In the field of Library and information center, Information and Communication Technology has brought many changes in physical and online service. Because of this our Library professionals have also some problems to face such changes in technology. Librarians have to change their role from traditional to techno savvy Librarian. We have to changes our approaches towards delivering of Library services. Librarians should collect, manage, preserve and deliver information in digital form. Nowadays it's very easy to get the information on Google in very short time with the help of Laptop, tablets, mobile phones etc. So it's a challenging task of Library professionals to manage and deliver digital collection and services. In this techno savvy age it is a need to initiate and start Library services and facilities through technological tools. Kiosk technology is one of the tools of them. In this paper, we are going to discuss about Kiosk types and its utilization and usefulness in various types of academic Libraries.*

**Keywords:** Library Kiosk, Self-Service Tool for Libraries

## **Introduction**

Nowadays, Libraries and Librarians play an important role in providing access to information, organizing it, and helping users to find the information their need. Accordingly, information services have become a key component for Libraries. The present user's interest is to get the information in need within a given timeframe. Though the present users can get access to the vast amount of information on the Internet and online databases, the role of Library information services has nowhere reduced. E-journals/Magazines, CDs, DVDs, online resources etc. also Libraries providing reference services, online services, RFID-based circulation systems etc. In recent years Libraries have used kiosk service for a Library function. As Dr S.R. Ranganathan said that in his fourth law to save the time of the reader. Library Kiosk service also saves the time of the users and assists. Library users for smooth working. Kiosk represents digital Library concepts and offers automated services to Library users. Services can include book issue, book Return, book renewal, cataloguing services, bibliographic services etc.als kiosk offer multiple benefits to Libraries.

## **Types of Kiosk Machine**

*1. Self-Service Kiosk:* Kiosk in self-service mode facilitates to use machine in a way that you don't have to wait for an employee to assist you, but it helps to directly interact with the company or a service provider that you are interested in. It saves your time to see and analyze services as per your way and choice. For example, ATVM is used to get the tickets at the railway platform. Here you have to simply approach the machine and select the options given on that screen and make a payment. Sign in of staff and students in colleges are another example of the self-service kiosk.

2. *Information Kiosk*: It's nothing but a device which is useful for giving information to the community. The information available in this Kiosk is very simple and understandable. User does not need any help or any advisor while using the information Kiosk machine. There may be an interactive and non-interactive Kiosk is available as per the requirement and needs of the organizations or companies. For example, Kiosk are available at hospitals, restaurants, hotels, companies etc.

3. *Internet Kiosks*: Such type of Kiosk has an internet connectivity to facilitate the users to access information on internet and other purposes. For the accessibility, it charges some cost for specific time period. It is mostly seen in hotels or other public places.

4. *Advertising Kiosks*: it is a type of Kiosk which is used for advertise of some product or any other thing. It's very useful to show the qualities and other parts of a product which attract the customer to their product. it impacts the selling of a product. Such type of kiosk we can see in Malls, Theatres etc.

5. *Way finding Kiosks*: This type of kiosk is very popular in public places. Wayfinding Kiosk is very useful to people to find their desire way where they have to go for specific purposes. It shows the roadmap to the users to understand the basic information about what the users are looking for. E.g. way finding Kiosks are generally seen in shopping mall where the customer wants to buy some product but could not be able to find the way, here this type of kiosk helps users to find exact way.

### **Benefits of Kiosk**

The above types of Kiosk have their own benefits which are commonly mentioned below.

1. *Lighten Users Irritation*: A perfectly design kiosk is very much helpful to minimize the user's irritation and satisfy users need because all the structured information in a very easy manner is given in it. It doesn't lose the concentration of the client to search the desire product or service he wants.

2. *Advertising of Product and Services*: An updated and modern Kiosk helps in making branding of the product and services. It makes tasks easy to create attraction and reliability. This helps in advertise your product which will effect in selling and utilizing the products and services.

3. *Minimum Exemption to Work of Employees*: This Kiosk will help your employees to minimize the work of customer service. Your organizational staff will be there to give the best service to the customers but Kiosk will help them to answer minor questions or problems of your customers, which is a very big task of day to day 's activities of your staff. This will save your employees time and give them some relaxation to concentrate on other important tasks. This will also impact on the customer also because they don't need any staff help to use or get the information about the service or work they have to enquire.

4. *Quickness and Timesaving Service*: Employees might not give a quick and timely service because of some physical constraints and limitations but the kiosk gives a timely and quick service by having touch screen facility and various features with it.

5. *Cost Effective and Build Efficiency*: Many organizations spend their money on employees to give best service to their customers. Various types of kiosks help organizations in saving cost on labor because it does the work of many employees with the same efficiency without having a break.

6. *Strengthening Usage and Selling of Product:* The major usefulness of well designed and well equipped Kiosk is to increase usage and sales of your product. It's not just a machine but an interactive path for the users or customers to know about the product or service. It promotes your product or service by having an user friendly screen or display. It increases your product sales and usage.

7. *Provide Security and Privacy Against Danger or Threat:* Most of us are not very much sure about the process of handling our debit or credit cards to any other persons for any payment. There may be a chance of fraudness. In this case a self service Kiosk helps you to keep your identity safe and make your payment securely. Such type of Kiosk can be seen in hotels, grocery stores or restaurants.

### **Critical Issues While Using Kiosk**

1. *Adjustability or Flexibility:* Most of the Kiosk required wired connectivity to operate it but it is not possible for every situation. Some of the services require more flexibility to access it but Kiosk may not fulfill it.
2. *Finance Factor:* There are various kiosks which prices are different as per the functionalities and facilities available with it. It impacts the selection of kiosks. Cost is very important factor while selecting a kiosk
3. *Trustworthy and Privacy:* While selecting any Kiosk, it is very important to think about its trustworthiness and privacy because it is connected with the intranet or internet. Your data might be copied by hackers or someone else. It's very important to give 24/7 information security to the selected kiosk which is a very challenging task.

### **Usefulness of Kiosk for Library and Information Centers**

In the present ICT environment, Libraries and information centers are also changing their roles from giving traditional to modern services and facilities. Kiosk also plays an important role in this regards. Various types of Kiosk are being useful for the Libraries to deliver Library services to the users. The following are the major and prime importance of Library Kiosk.

1. Kiosk is useful for giving Library information to the users.
2. It saves the time of Library staff to give instructions and suggestions of how to use Library services regularly.
3. It provides a platform to the users where they can access all the books, journals and other important information which is very important for the newly students who enter the Library first time
4. Library staff can demonstrate or give the Library presentation to the users of the Library or the committee members who visit the Library
5. Various links of e-journals database, Library website, eBooks and other e databases can be shown on the screen of Kiosk.
6. Kiosk helps to minimize the Library staff requirement in Library because it itself has an user friendly interface which is familiar to Library users and they rarely need help of Library staff.
7. Library OPAC can be shown with the help of Kiosk to give the bibliographic information of books and other materials of the Library.
8. Library kiosk provides a touch screen to the users which are very best for quick access to Library services and getting information about the Library.

### **Library Service and Self Service Kiosk Usefulness**

There are various types of services provided by Libraries out of which circulation service is very fundamental and major service provided by Libraries. In this regard, self-service Kiosk helps

Library staff to automated check in and check out books. It saves the time of the users and the Library staff.

### Implementation of Kiosk in Central Library of D Y Patil College Of Engineering, Akurdi, Pune

Library kiosk has been implementation in the central library of D Y Patil College of engineering, Akurdi,Pune. Various e-resources, OPAC, feedback form, book requisition form and all the related library services and facilities information have been made available on the display of library kiosk. It has a touch screen display to operate library kiosk.



Fig.1 Implementation of Kiosk in Central Library of D Y Patil College Of Engineering

### Conclusion

Library Kiosk plays an essential role in delivering Library and information services. Library users can not only borrow, return, and renew items at our self-service kiosks but they can also find and download digital titles, discover events and programs, receive reading recommendations, and pay fines and fees. The main purpose of the Library is to provide quality services to satisfy users with the right information at the right time. It's a necessity of time for the library to upgrade with new technologies. Kiosk provides easy, fast and suitable information related library to users.

### References

[1] 6 types of kiosks you should know about in 2022. (2022). Retrieved on 26 February 2022, from <https://www.lamasatech.com/blog/5-types-of-kiosks-that-you-should-know-about/>

- [2] Devi, C.K.,Devi, S.R., Kathija S. Rasagna V., Chaduvula K.(2021). Library information management system using KIOSK. EPRA International Journal of Research and Development, 6(7), 412-423.Retrieved from [https://www.researchgate.net/publication/308786787\\_A\\_Manual\\_for\\_Referencing\\_Styles\\_in\\_Research/link/57f14ed008ae8da3ce4ec234/download](https://www.researchgate.net/publication/308786787_A_Manual_for_Referencing_Styles_in_Research/link/57f14ed008ae8da3ce4ec234/download)
- [3] Holowicki, J., Benefits of interactive KIOSKS. (2020). Retrieved on 27 February 2022, from <https://www.promotion.tech/blog/benefitsofinteractivekiosks/>.
- [4] Kaur, H., Malhotra, S. (2018). Use of “Kiosks” as a Self Service Tools in Libraries. In 5th International Symposium on Emerging Trends and Technologies in Libraries and Information Services (ETTLIS), Noida, India, IEEE.
- [5] Wane S.A., (2019).KIOSK: A new trend for Digital Library. ELA Asia Pacific Journal of Library Management and Information Technology, 5(1), 1-5. Retrieved from [https://www.researchgate.net/publication/330924708\\_KIOSK\\_A\\_NEW\\_TREND\\_FOR\\_DIGITAL\\_LIBRARY](https://www.researchgate.net/publication/330924708_KIOSK_A_NEW_TREND_FOR_DIGITAL_LIBRARY)
- [6] What is a Kiosk – Definition, Types, Pros, and Cons & Examples. Retrieved on 18 February 2022, from <https://www.marketingtutor.net/what-is-a-kiosk-definition-types-pros-cons-examples/>

# Influence of ICT on Vocational Interests of GCE A/L Students in Kurunegala District, Sri Lanka

K.K.A.H. Kumarasinghe<sup>1</sup> and Y.H.P.S.S. Pathirathna<sup>2</sup>

<sup>1</sup>Dept. of Indigenous Health Sciences, <sup>2</sup>Department of Technology

<sup>1&2</sup>Faculty of Indigenous Health Sciences & Technology,

Gampaha Wickramarachchi University of Indigenous Medicine, Yakkala, Sri Lanka

E-mail: harshani@gwu.ac.lk

## Abstract

*The aim of this study was to investigate the influence of ICT on the vocational interests of GCE A/L students of the Kurunegala district. A sample of one thousand GCE A/L students was considered by using a simple random sampling technique. To data collection, researchers developed two scales – the Vocational Interests Scale and the Scale on Influence of ICT for vocations. Before administering these tools, researchers checked the reliability and validity of these Scales. In order to test the hypothesis of the study, the data were analyzed by using statistical methods like Product Moment Coefficient of Correlation and Regression Analysis. The study revealed that – a positive and significant relationship was found between ICT and the Vocational Interests of GCE A/L students. 30.6 percent of the variance of Vocational Interests was contributed by ICT.*

**Keywords:** ICT, Vocational Interest, School Education

## Introduction

In this expeditious transmuted modern sophisticated techno-scientific ecumenical society where internet, cell phone, e-mail, chatting, liberalization, globalization etc. are the frequently used terminologies of our adolescent generations. This 21st Century is known as the age of science and technology because of the tremendous advancement that has been made in scientific, technological and industrial fields. Exhilarating revelations and incipient inventions along with technological developments which are taking place every day are influencing human beings in every sphere of life, work and play ecumenical. It has influenced every aspect of life, like education, business, industry, banking, agriculture, medicine and sundry other fields, i.e. incipient and emerging technologies challenge the traditional edifying-cognition process and the ways of education.

The present education system of Sri Lanka is aggravating the quandary of unemployment. One of the most challenging authoritative ordinances of this 21st Century is to abstract unemployment and impecuniosity and procure a sustained economic magnification. Sri Lanka's changeover to an erudition-predicated economy requires an incipient generation of edified and adroit people. Consequently, it is the responsibility of society to prepare the puerile generation for this unique authoritative ordinance of the 21st Century. Today, vocational education has become synonymous with quality life as it contributes significantly to promoting the intrigues of individuals, enterprises, economy and society. The social, commercial, technical and cultural development of Sri Lanka depends on secondary edification. Secondary edification is one of those stages of education, which is given after primary edification but afore university inculcation. It plays a paramount role in the training of the youth in order to take an active part in the social reconstruction and economic development of a nation. It is at this stage that students acquire those basic skills and faculties which enable them to enter the job market or go for higher education. Therefore, the secondary inculcation system should be made so practical that the students after passing this stage do not run for admissions to universities and remain unemployed but become economically independent by having acquired some vocational adeptness of productive nature.

Thus, these students during their school years require avail in understanding the desideratum and consequentiality of career scheduling. Consequently, educators and administrators need to probe for the sundry career orientations, with a view to understanding the ways in which GCE A/L students make career scheduling and the sundry factors, which influence their scheduling.

It has been observed that students in Sri Lanka make career plans without having enough erudition; facilely falling to the pressures of parents and peers, thereby coercing them to take fictitious career decisions. Lamentably, this has led to dissatisfaction and maladjustments in their careers. Hence, it has become essential to give due weightage to the factors which influence their Vocational Intrigues in order to minimize the maladjustments in their vocational spheres as life contentment and ecstasy, to an astronomically immense extent depends upon job contentment which is the outcome of interest which one takes in his career. Vocational Interests designates an individual's interest towards a particular vocation i.e. the desire to work in a particular field as denotes to earn his/her livelihood. Vocational Fascinates is one of the most enduring and compelling areas of individual differences (Lubinski & Dawis, 1995) and the most popular betokens for characterizing, comparing and matching persons and environments (Hogan & Blake, 1996).

The basic skills of reading, writing and arithmetic (3 R's) remain the foundation of schooling and students learning. It has been found from various studies conducted in Sri Lanka and abroad that there was a positive Influence of use of ICT in teaching-learning of various subjects. As in the study of Mauther, M. Z. (1999) revealed that when the computer was used to its full potential, it helped students achieve more in learning vocabulary, grammar and comprehension to the learner's with different IQ, motivation and attitude

The rudimentary skills of reading, writing and arithmetic (3 R's) remain the substratum of schooling and students learning. It has been found from sundry studies conducted in Sri Lanka and abroad that there was a positive Influence of avail of ICT in teaching-learning of sundry subjects. As in the study of Mauther, M. Z. (1999) revealed that when the computer was habituated to its full potential, it availed students achieve more in learning lexicon, grammar and comprehension to the learner's with different IQ, motivation and posture.

It availed the students learn better because it provides them with a lot of liberation and responsibility to learn at their own pace and the students were found to have positive posture towards Computer Aailed English language Teaching. Samal, Y. (2000) found that both the Edification Television Programme and School Broadcast Programme to have positive Influence on school achievement of pupils. Yadav, K. (2004) had found a consequential gain in terms of students' achievement through ICT enabled instructional package. According to Rathod, J. (2005) the developed ICT based instructional package was more Influence for teaching English grammar and also the students had constructive responses towards the developed ICT based instructional package. The students and teachers both were found to have a favorable opinion towards the developed instructional package. Siddique, U. (2013), confirmed that Computer Assisted Instruction (CAI) was an Influence tool for teaching and learning Physical Sciences.

Thus, technology avails students in accomplishing their goal of having a solid substructure of rudimentary skills and inculcating in them an interest to learn. Realizing this, schools are now introducing ICT tools to ameliorate students' rudimental skills. The utilization of audio and video tools in the classrooms rejuvenates the subject is consequential, which avails to stimulates student's minds and thus facilitates learning. Pictures sound and animation, multimedia



considerably enhances students' facility to recall fundamental facts, as well as ameliorating their construal of intricate systems.

Researchers, after scrutinizing sundry reviews of cognate literature had observed that numerous researches on the relationship between Vocational Interests and other variables like socio-economic status, gender difference, father's career, etc. were conducted. But in today's expeditious transmuting modern techno-scientific ecumenical society of 21st Century, our students have an incipient style of celebrating which makes them different and independent right from an early age. They want to decide their own vocations and determine their own future professional magnification. This prompted the present Researchers to work with variables other than the types of variables mentioned above and ergo, wanted to ken how Vocational Interests of today's generation is Influenced by ICT. Researchers from a review of cognate literature conducted both in Sri Lanka and abroad on variable ICT had found that most of the studies had positive Influence of ICT on sundry edifying subjects like English, French, etc. and additionally found positive Influence of ICT on student's achievement. These studies incentivized researchers to take ICT as a variable in the present study and takenits Influence on Vocational Interests of GCE A/Ls students.

### **Objectives of the Study**

To find the Influence of ICT on Vocational Interests of GCE A/L students.

### **Hypothesis of the Study**

In order to achieve the above objective, the following null hypothesis was formulated:

$H_0$ : There will be no significant Influence of ICT on Vocational Interests of GCE A/L students.

### **Methodology**

The Research Design Was Descriptive as the information amassed from the subjects was not manipulated. The population utilized for the study was students of GCE A/Ls of Kurunegala district. One thousand secondary school students were considered by utilizing simple random technique as a sample. For the purport of amassment of data, researchers developed two scales – (i) Vocational Interests Scale and (ii) the Scale on Influence of ICT for Vocations. Afore administering these implements, researchers checked the reliability and validity of these scales.

In order to refine and have a statistically sound and theoretically consequential 'Vocational Interests scale' researchers had applied factor analysis. Factor Analysis singled out nineteen (19) factors or areas with eighty (80) items along with their corresponding factor loadings. The factors or areas are –Teaching, Performing Arts, Engineering, Health, Clerical Jobs, Entrepreneurship, Sports Professionals, Social Scientist, Contrivance Technician, Finance & Accounts, Social Services, Conventional Jobs, Creative Arts, Managerial Services, Airline Services, Investigative Services, Media, Counselor, and Literary Arts. Reliability was found to be 0.939 by utilizing the Cronbach Alpha formula. The content validity of the Vocational Interests Scale was established by circulating the content of the scale among a panel of experts in the field of Education and Psychology. Researchers also developed the Scale on Influence of ICT (IT) for Vocations.

Factor Analysis singled out six (06) factors with thirty (30) items along with their corresponding factor loadings. The factors were – Knowledge of IT, Utilization of IT Services, IT & Artistic Jobs, Vocation Options in Computer, IT & Entrepreneurial Services and IT for Human Welfare. The reliability of the scale was 0.844 by utilizing the Cronbach Alpha formula. The Scale on Influence of ICT for Vocations was circulated among a panel of experts in the field of Education and Psychology for content validity.

### Findings of the Study

The following was the finding of this present study: Positive and significant relationship was found between ICT and Vocational Interests of GCE A/L students. 30.6 percent of the variance of Vocational Interests was contributed by ICT. Product Moment Correlations of Coefficient and Simple Regression Analysis was used as the collected data were normally distributed.

In order to find the Influence of ICT on Vocational Interests, researchers first analyzed the scores to study the relationship between ICT and Vocational Interests of GCE A/L students. The following table (Table I) depicts the value of Product Moment Coefficient of Correlation.

TABLE I PRODUCT MOMENT COEFFICIENT OF CORRELATION BETWEEN ICT AND VOCATIONAL INTERESTS OF GCE A/L'S STUDENTS (N = 1000)

Variables	df	Calculated r	p
ICT	998	0.554**	0.000
Vocational Interests			

\*\* Significant at the 0.01 level (2-tailed), df: degree of freedom

From table I, it could be said that the coefficient of correlation between ICT and Vocational Interests was 0.554\*\*, significant at 0.01 level which indicates a positive and significant relationship. As there was a significant relationship between ICT and Vocational Interests, researchers could determine the Influence of ICT on Vocational Interests. The following table (Table II) depicts the value of Simple Regression Analysis.

TABLE II SIMPLE REGRESSION ANALYSIS BETWEEN ICT AND VOCATIONAL INTERESTS OF GCE A/L STUDENTS (N = 1000)

Model	Unstandardized Coefficients		Standardized Coefficients		
	B	Std. Error	Beta	T	Sig
(Constant)	85.985	8.276	0.554**	10.390	.000
ICT	1.584	0.075		20.996	.000
R=0.554			R Square=0.306		

\*\*Significant at 0.01 level (2-tailed).

It has been observed from the above table that the square of R was 0.306, which designates that ICT contributed 30.6 percent of the variance in Vocational Interests. In integration, the positive Beta value, which was paramount at 0.01 level, denoted that ICT had a positive Influence on Vocational Fascinates. Consequently, researchers are of the opinion that ICT has availed the students to enhance their Interests about the different areas of vocations i.e. ICT has consequential Influence on Vocational Interests of GCE A/L students. Hence, the above null hypothesis is rejected.

Furthermore, researchers calculated the correlation values between six dimensions of ICT and the nineteen areas of Vocational Interest by using Product Moment Correlation of Coefficient. The following table (Table III) shows the correlations values between them.

TABLE III COEFFICIENT OF CORRELATIONS BETWEEN SIX DIMENSIONS OF ICT (IT) AND NINETEEN AREAS OF VOCATIONAL INTERESTS OF GCE A/L STUDENTS (N = 1000)

Areas of Vocational Interests	Dimensions of ICT					
	Knowledge of IT (IT-1)	Use of IT Services (IT-2)	IT & Artistic jobs (IT-3)	Career options in Computer (IT-4)	IT & Entrepreneurial Services (IT-5)	IT for Human Welfare (IT-6)
Teaching	.193**	.132**	.290**	.231**	.329**	.189**
Performing Arts	.149**	.158**	.620**	.208**	.265**	.154**
Engineering Services	.221**	.135**	.002NS	.229**	.153**	.089**
Health Services	.206**	.167**	.215**	.215**	.280**	.184**
Clerical Jobs	.161**	.066*	.307**	.279**	.394**	.196**
Entrepreneurial Services	.174**	.081**	.262**	.267**	.351**	.180**
Sports Professionals	.222**	.187**	.235**	.291**	.351**	.171**
Social Scientists	.225**	.109**	.263**	.281**	.421**	.185**
Gadget Technicians	.226**	.189**	.224**	.398**	.324**	.225**
Finance & Accounts	.259**	.162**	.153**	.281**	.298**	.187**
Social Services	.087**	.028NS	.395**	.123**	.285**	.066*
Conventional Jobs	.180**	.082**	.174**	.205**	.293**	.177**
Creative Arts	.183**	.266**	.334**	.217**	.190**	.117**
Managerial Services	.159**	.105**	.137**	.219**	.232**	.148*
Airline Services	.261**	.230**	.083**	.152**	.184**	.089**
Investigative Services	.172**	.117**	.098**	.187**	.244**	.116**
Media	.166**	.130**	.360**	.194**	.353**	.139**
Counselor	.177**	.126**	.159**	.214**	.268**	.171**
Literary arts	.156**	.151**	.152**	.133**	.219**	.103**

\*Significant at 0.05 level (2-tailed). \*\*Significant at 0.01 level (2-tailed). NS: Not Significant at any level

It was evident from the above table that all the dimensions of ICT (Knowledge of IT, Use of IT Services, IT & Artistic jobs, Career Options in Computer, IT & Entrepreneurial Services and IT for Human Welfare) had positive and significant relationships (at 0.01 and 0.05 levels, 2-tailed) with all the areas of Vocational Interests (Teaching, Performing Arts, Engineering Services, Health Services, Clerical Jobs, Entrepreneurial Services, Sports Professionals, Social Scientists, Gadget Technicians, Finance & Accounts, Social Services, Conventional Jobs, Creative Arts, Managerial Services, Airline Services, Investigative Services, Media, Counselor and Literary Arts). The IT & Artistic Jobs – one of the dimensions of ICT however, had positive but not-significant (at any levels) relationship with the Engineering Services area of Vocational Interests. Finally, it has been denoted that Positive and significant relationship was found between ICT and Vocational Interests of GCE A/L students. 30.6 percent of the variance of Vocational Interests was contributed by ICT.

## Conclusion

It was concluded from the finding of the objective that students who were habituated with ICT were found to be more fascinated to explore the world of vocations. Hence, it may be concluded that ICT played a very influential role in inculcating Vocational Interests among GCE A/L students. This trend is because of ICT revolution that is affecting the whole world and it has been instrumental in bringing down the boundaries, atomized variants of jobs; opened numerous opportunities for the cross-section of people the world over, enhanced generation, development and information of vocational guidance more facilely accessible to all and consequently Sri Lanka is additionally suddenly witnessing an incipient age of vocations, vocations that were unheard of and undiscovered in anterior years. In the present era, ICT has played a paramount role in every sphere of life and education is no exception to it. The result of the present study additionally found that the utilization of ICT implements had a positive Influence on Vocational Interests. This betokens that ICT plays a consequential role in inculcating students' Vocational Interests. ICT has opened up a plenary incipient potential in technology-predicated learning. The present findings should incentivize every edifying institution to utilize and infuse ICT into their curriculum. The present investigation was restricted only to students studying in government schools of Kurunegala district; the findings cannot be generalized for all GCE A/L students. Hence, in order to generalize these findings, further research could be done with students of other Schools. In order to get better, authentic and generalized results for GCE A/L students, districts other than Kurunegala could be considered in the future.

## References

- [1] Hogan, R., & Blake, R.J. (1996). Vocation Interests: Matching Self-Concept with the Work Environment. In Murphy, K.R (Ed.), *Individual Differences and Behaviour in Organization*. San Francisco: Jossey-Bass, 89-144.
- [2] Lubinski, D., & Dawis, R.V (1995). *Assessing Individual Differences in Human Behavior: New Methods, Concept And Findings*. Palo Alto CA: Davies-Black.
- [3] Mohankumar, V., & Sanjay, B. (2014). NVEQF ToNSQF: The Journey and Outcome. *Sri Lankan Journal Of Adult Education*, 75(2), April-June 2014, 37-60.
- [4] Muather, M, Z. (1999). Development Of Computer Assisted English Language Teaching For VIII Standard Students. Abstract of Research Studies Conducted By Teacher Education Institutions In Sri Lanka, D.R. Goel, R.L. Madhavi, CASE, The M.S. University Of Baroda, 246.
- [5] Rathod, J. (2005). Development And Implementation Of An ICT Based Instructional Package For English Grammar To Gujarati Medium Students Of Standard VIII Of Jamnagar City, Abstract of Research Studies Conducted By Teacher Education Institutions In Sri Lanka, D.R. Goel, ChhayaGoel, R.L. Madhavi, CASE, The M.S. University of Baroda, 266.
- [6] Samal, Y. (2000) Influenceiveness of the School Broadcast Programmes of All Sri Lanka Radio (AIR) and Educational Television (ETP) Programmes of Doordarshan with references to school achievement of the learners, Abstract of Research Studies Conducted by Teacher Education Institutions in Sri Lanka, D.R. Goel, Chhaya Goel, R.L. Madhavi, CASE, The M.S. University of Baroda, 249.
- [7] Siddiqui, U (2013). A Comparative study of the Influences of Traditional Teaching and Computer Assisted Instructions on GCE A/L students' attitude and achievement in Physical Science. Unpublished PhD Thesis, Kurunegala Muslim University.

# Role and Impact of Blockchain with Special Reference to Academic Libraries

Rikta Turul<sup>1</sup> and Diprit Turul<sup>2</sup>

<sup>1</sup>Dept. of Library and Information Science, Kalinga University, Chhattisgarh, India

<sup>2</sup>Dept. of Computer Science & Technology, Guru Nanak Institute of Technology, Kolkata, India

E-mail-turulrikta@gmail.com

## Abstract

*As the world becomes increasingly more digital and the amount of data has grown over the past decade, Academic libraries are continuously facing the problem of providing a huge amount of e-resources, while also ensuring their legitimacy and availability. However, with the development of block chain technology, its ability to utilize distributed ledgers and advanced cryptographic security a measure, a transformative solution has presented itself. Libraries will be hugely impacted by this innovative technology through the implementation of block chain technology through technological advancement. This report will zoom in on the possible impacts and all the possible outcomes and provide a case study on the implementation of BLOCKCHAIN in the Academic library.*

**Keywords:** Block chain, Cryptography, Data security, academic Library, Distributed, Network.

## Introduction

### A. Block Chain

Block chain Also Known as Distributed ledger Technology (DTL) is one of the most advantageous inventions of modern era. It makes the history of any digital asset transparent and unalterable through the use of Decentralization and cryptographic hashing. There 3 main parts of Block chain: Blocks- Every chain in a block chain consists of multiple blocks and every block consists of

**Nodes-** one of the most important concepts in block chain technology is the decentralisation of data. No one computer or an organization can claim the chain, instead the big chain is distributed in various nodes which are inter connected.

**Miners-** New blocks on a blockchain is created through a process called Mining. every block in a block chain has its unique nonce and hash but also refers to the hash of the previous blocks in the chain so mining is very difficult specially when it is a larger chain.

Block chain has various use case but the main use case we are going to discuss is the use of blockchain in ACADEMIC library. Although Blockchain is a comparatively new technology it already has a rich and interesting history, Blockchain originated from earlier ideas about secure digital transactions and record-keeping. 2008: Satoshi Nakamoto publishes the Bitcoin whitepaper, outlining a decentralized digital currency.

### B. Academic Library

The academic library serves a very important role in providing students the required information and resources as it has a vast collection of books, periodicals, and other materials, often at a very low or no cost. This also opens up a world of knowledge and information to people. Libraries are much more than a place to borrow and return books it is a bank of knowledge which when utilized carefully can be very beneficial.

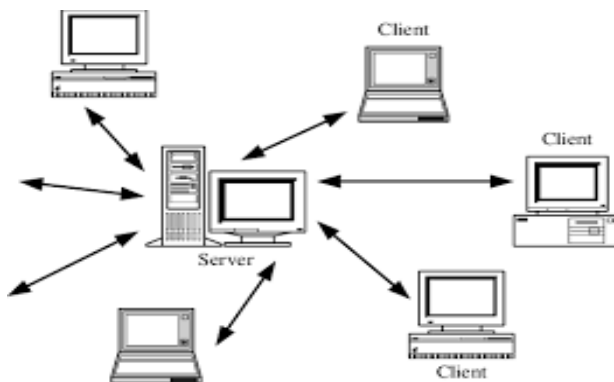

Fig. 1 General representation of Client server Network

However, challenges are increasing – as librarians; we are suffering from the navigation of misinformation, rumour, and so on. As a result, Block Chain Technology represents a new way of thinking, analyzing, and solving problems. Libraries provide a wealth of information resources, including academic journals, books, e-books, databases, and multimedia materials. Libraries conduct workshops and training sessions on topics like information searching, critical thinking, and source evaluation. By providing accessory source training and outreach programs academic libraries play a critical role in empowering information-poor users and bridging the gap. The 3 main advantages of academic libraries:

1. Access to Information
2. Learning and Education
3. Community and Social Connection

Academic Libraries are more exciting than ever because of the inclusion of many user-oriented programs, digital services, and even market place to exchange books. However, libraries keep facing challenges such as misinformation, rumour and so on. Many libraries host art exhibits, film screenings, and other cultural events. This allows individuals to experience different cultures and broaden their horizons. Sure, the image you sent me is of the Five Laws of Library Science, which were proposed by S.R. Ranganathan in 1931. The laws are:

1. Books are for use.
2. Every reader his/her book.
3. Every book has its reader.
4. Save the time of the reader.
5. The library is a growing organism.

### *C. Networking in a Digital Library*

Every library should be inter connected to share data over the internet so that the decentralized data can be accessed and created. So, we need to take a look at the connection between two computers over internet.

*1. Client–Server Network:* Servers: Centralized computers that store, manage, and provide resources (files, applications, databases, etc.) to clients. Clients: Devices (computers, smartphones, tablets) that request and access resources from servers. Client-server networks provide a structured and efficient way to share resources and services across multiple devices, making them a

fundamental building block of modern computing infrastructure. Easier to manage resources, security, and updates from a central server. Easily add more clients or servers as needed to accommodate growth.

2. *Peer-to-Peer Network*: A peer-to-peer network is a decentralized network architecture where each node acts as both a client and a server. Devices join the network and share a portion of their resources, such as storage space, processing power, or bandwidth. No single point of failure makes the network more resilient to outages and attacks. No need for expensive central servers or infrastructure. Data is typically stored and distributed across multiple nodes, enhancing privacy. The underlying technology behind crypto currencies like Bitcoin relies on a P2P network.

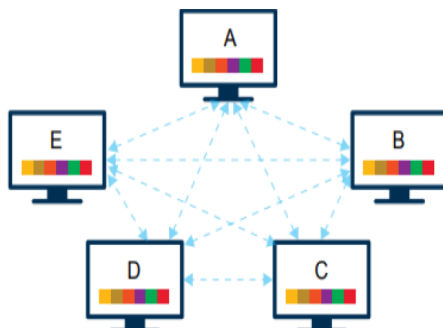

Fig.2 General representation of Peer-to-peer Network

As we can understand from the above study, we need to establish a well-connected peer-to-peer network to introduce Block chain technology in our academic library. So, if we introduce block chain in the library we need to take a look at some key points related to the library: -

1. Distributed
2. Immutable
3. Verifiable

When truth, Trust, and Technology a factor to consider we can rely on Block chain for information sharing. It has authority proof to check Data Entering the system.

### How can Block chain help in a library-?

The areas of application of Block chain in the library are:

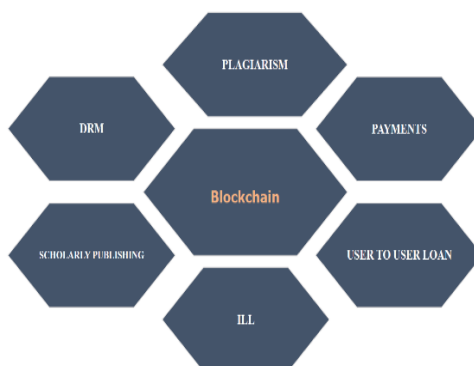

Fig. 3 Association of Block chain with aspects of Library

1. It can help Share digital assets between different libraries and institutions: - Sharing digital assets between libraries and institutions can be a powerful tool for promoting collaboration, accessibility, and the democratization of knowledge. In today's digital age, where information is readily available but often fragmented, effective resource sharing is more crucial than ever.
2. Improve digital rights management: - Block chain removes the need for centralized intermediaries, empowering creators to manage their rights directly and securely. Encryption to protect content from unauthorized access. Block chain-based DRM platforms can give creators more control over their work and empower users to access and use content in more flexible and transparent ways.

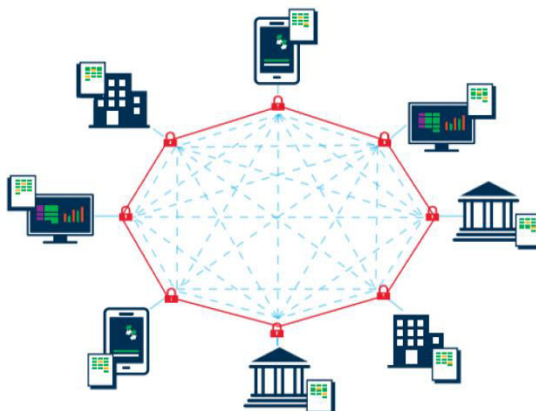

Fig.4 Connection between different devices in a library

3. OCLC enhancement: - Decentralized Bibliographic Data Management Block chain could create a distributed, global catalog of bibliographic records, eliminating reliance on centralized systems and enhancing resilience. Secure and Transparent Resource Sharing Smart contracts could automate lending and borrowing processes, reducing administrative overhead and expediting resource sharing
4. Great Civic engagement: - Block chain technology has the potential to enhance civic engagement in several ways. Here are some ways in which block chain can be leveraged for great civic engagement:
  - a. Transparent and Secure Voting Systems
  - b. Decentralized Identity Verification
  - c. Smart Contracts for Governance
  - d. Crowd funding for Civic Projects
5. Digital security to safeguard against data censorship: - While traditional digital security tools offer protection, block chain technology introduces a unique approach to safeguarding data against censorship. Here's how it empowers individuals and organizations. Technology in Development: Block chain technology is still evolving, and its potential for combating censorship is actively being explored.

### Usage of Block chain in Library

Block chain In the library is opening various different opportunities that were out of the limit before block chain was around. We will take a look at various different various opportunities: -



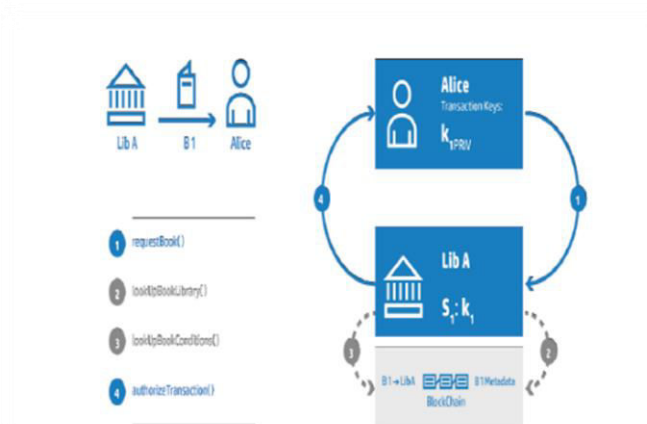

Fig. 5 The block representation of library and client interaction

Inter-library digital preservation and tracking: - Inter-library digital preservation and tracking is a complex and emerging field, Shared repositories, built and maintained by consortia of libraries, offer centralized storage and access to preserved digital objects. Examples include LOCKSS and CLOCKSS. Tools like Archipelagic and Dur Cloud track the lifecycle of digital objects, including migration, replication, and access events. Sharing resources and expertise across libraries reduces individual preservation costs. Long-term preservation through distributed storage and expertise.

*A. Corporate Library Records Keeping:* Corporate libraries play a crucial role in managing, storing, and providing access to valuable information that fuels company operations and decision-making—E-books, databases, presentations, videos, audio recordings, software, emails, etc. There are various advantages such as improved information access and usability for employees and enhanced decision-making with readily available data.

*B. Operational Data Management:* Effective records keeping is essential for this function, ensuring information is readily available, secure, and compliant with regulations. Here's a breakdown of key aspects of corporate library record keeping. Choosing appropriate storage mediums (physical shelves, digital repositories) and retrieval methods (online portals, manual search). Software for automating many record-keeping tasks, including cataloging, circulation, and user management. Tools for creating and managing website content, often integrated with digital libraries.

*C. Scholarly Publishing:* The block chain can help librarians keep track of the publications done by several scholars all around different institutes and achieve that work, especially in the world of Journal articles, this creates a time-stamped record in the block chain that other researchers can quickly verify in the future. They did this by cryptography hash of a trial protocol.

*D. Digital Rights Management:* Systems and technologies that protect and manage the use of digital content, ensuring that copyright holders maintain control over their intellectual property. Eliminates the need for centralized intermediaries, reducing costs and potential points of failure. Automates tracking of content usage and rights management. They are protecting the authenticity and ownership of digital art and collectibles.

## Conclusion

In conclusion, we can state that Block chain technology presents a groundbreaking opportunity to revolutionize academic libraries. It is based on decentralization and verifiable security offers solution to the critical challenges libraries face in the digital age, such as ensuring data integrity. The potential applications of block chain in academic libraries are vast and exciting. Despite these challenges, the transformative potential of block chain for academic libraries is undeniable. Emphasize the future potential of block chain and its promise to revolutionize academic libraries. However, implementing block chain in libraries requires careful consideration. Challenges like technical complexity, scalability, and integration with existing systems need to be addressed. By incorporating these elements, you can craft a compelling and insightful conclusion that leaves a lasting impression on your readers.

## References

- [1] Efimov, D., & Ros chin, P. (2018). The all-pervasiveness of the block chain technology. *Procedia Computer Science*, 123, 116–121. <https://doi.org/10.1016/j.procs.2018.01.019>
- [2] Gray, G. R. (2021). Understanding blocks chain. *Block chain Technology for Managers*, 11–41. [https://doi.org/10.1007/978-3-030-85716-5\\_2](https://doi.org/10.1007/978-3-030-85716-5_2)
- [3] Hayes, A. (n.d.). Block chain facts: What is it, how it works, and how it can be used. Investopedia. <https://www.investopedia.com/terms/b/blockchain.asp>
- [4] Hussaini, S., Haruna, M., & Shrivastava, D. K. (2022). Block chain: The gateway to new technology and its applications for academic libraries. *Journal of Information Technology and Sciences*, 8(1), 12–21. <https://doi.org/10.46610/jjoits.2022.v08i01.003>
- [5] Library technology reports. (n.d.). <https://journals.ala.org/index.php/ltr>
- [6] Lu, Y. (2019). The Block chain: State-of-the-art and research challenges. *Journal of Industrial Information Integration*, 15, 80–90. <https://doi.org/10.1016/j.jii.2019.04.002>
- [7] Marques da Fonseca, L., Barzegar, H., & Pahl, C. (2023). Decentralized identification and information exchange in distributed, block chain-based internet architectures: A technology review. *Proceedings of the 19th International Conference on Web Information Systems and Technologies*. <https://doi.org/10.5220/0012254900003584>
- [8] Merrell, I. (2022). Block chain for De-centralized Rural Development and Governance. *Block chain: Research and Applications*, 3(3), 100086. <https://doi.org/10.1016/j.bcra.2022.100086>
- [9] Sanjay, & Nabihasan. (2020). Block chain technology and its application in libraries. *LIBRARY HERALD*, 58(4), 118–125. <https://doi.org/10.5958/0976-2469.2020.00030.10>

# Artificial Intelligence in Academic Libraries

**S. Kamalaveni<sup>1</sup> and Dr. G. Ulaganathan<sup>2</sup>**

<sup>1</sup>Research Scholar, <sup>2</sup>Research Guide, Associate Professor / Librarian & Head

<sup>1&2</sup>Department of Library and Information Science,

Dr. SNS Rajalakshmi College of Arts & Science, Coimbatore, Tamil Nadu, India

E-mail: kamalavenimba.veni@gmail.com, drgulaganathan@gmail.com

## Abstract

*Artificial Intelligence is revolutionizing libraries by improving functionality, data analysis, remote access, and big data research. It's also improving accessibility for visually disabled users, using AI-powered text-to-speech software. AI can perform routine tasks that require human expertise, freeing up librarians to focus on advanced research. This technology is increasingly important in education, research, and mobile devices.*

**Keywords:** Artificial Intelligence, Academic Libraries.

## Introduction

Artificial Intelligence and new technology are revolutionizing libraries, improving search capabilities, and transforming their role in society. AI-powered search engines make it easier for users to find necessary information. Artificial intelligence is being used in library cataloging and indexing services to automate the process of assigning subject headings and keywords, saving time and resources, and ensuring accurate and comprehensive indices of library materials. Artificial Intelligence technology can analyze user behavior, library materials usage, and preferences to improve services and enhance offerings. It can also assist in digital preservation efforts, updating all library materials when implementing new technology, ensuring long-term preservation of digital materials.



Artificial Intelligence Library



Fig.1 Artificial Intelligence in Academic Libraries

## **Intelligence**

Artificial Intelligence (AI) refers to the development of digital computers or robots capable of performing tasks associated with intelligent beings, such as reasoning, discovery, and learning from past Experiences.<https://www.britannica.com/technology/artificial-intelligence#ref219078> (Retrieved on 02.10.2023)

## **Concept and Definition of Artificial Intelligence**

John McCarthy, a Stanford Professor, coined the term "AI" in 1955, focusing on the science and engineering of creating intelligent machines capable of learning, similar to humans. (Retrieved on 03.10.2023)<https://hai.stanford.edu/sites/default/files/2020-09/AI-Definitions-HAI.pdf>

## **Definition of Artificial Intelligence**

Defining AI is challenging due to the lack of a universally accepted definition, leading to confusion. The variety of definitions is inherent to the nature of artificial intelligence.

*In Its Broadest Definition*, AI is often associated with algorithms, but this is not a useful analysis. Algorithms, derived from Persian mathematician Mohammed ibn Musa al-Khwarizmi, predate AI and can include tasks like pocket calculator operations or cookbook instructions.

*In Its Strictest Definition*, AI, the imitation of human intelligence, is not currently exist due to its simple applications, making its definition inappropriate for our report.

A Common Definition of AI is a technology that enables machines to imitate complex human skills, but its exact definition remains unclear as it doesn't specify the specific skills required for AI to perform complex tasks in complex environments. AI refers to systems that display intelligent behavior by analyzing their environment and taking actions with some degree of autonomy to achieve specific goals, as defined by computer scientist Nils John Nilsson and the High-Level Expert Group on Artificial Intelligence. [https://link.springer.com/chapter/10.1007/978-3-031-21448-6\\_2](https://link.springer.com/chapter/10.1007/978-3-031-21448-6_2). (Retrieved on 03.10.2023) H. Sheikh *et al.*, Mission AI, Research for Policy, 2Nilsson, 2009: 13.

## **Objective of Study**

1. The study aims to understand the concept of artificial intelligence and its impact on libraries.
2. The study aims to assess the readiness of academic libraries to utilize artificial intelligence.
3. The study aims to identify the obstacles libraries encounter when implementing artificial intelligence.
4. The study aims to understand the prerequisites for incorporating artificial intelligence technology into the academic libraries sector.
5. The goal is to improve academic library services and facilities.
6. The study seeks to comprehend the prerequisites for integrating artificial intelligence technology into the academic library sector.
7. The goal is to provide top-notch service to users
8. To establish a well-equipped digital library.
9. The goal is to establish a high-quality library policy that facilitates easy information retrieval.

## **Review of Literature**

Isaiah Michael Omame and Juliet C. Alex-Nmecha (2020) Artificial intelligence systems can be utilized in various services such as technical, reference, circulation, resource management, and information retrieval/dissemination in libraries.

Subaveerapandiyan A (2023) Libraries must balance AI's benefits with human-centric values, enhancing librarians' work. Further research is needed to understand AI's long-term impact on library operations. Collaboration between libraries, researchers, and developers is crucial for AI solutions. Knowledge sharing and best practices exchange are essential.

### **IFLA Statement on Libraries and Artificial Intelligence**

IFLA highlights the transformative capabilities of artificial intelligence systems, highlighting their potential for public welfare and innovation, provided proper preparations and ethical considerations are taken.

Kaijun Yu *et al.*, (2019) Artificial intelligence will transform the education system, making libraries more important as social education, learning centers, knowledge centers, and communication centers. Libraries should embrace AI positively, enhancing knowledge exchange and interpersonal interactions, and promoting service efficiency.

Aylin Ecem Gürsen *et al.*, (2023) This case study explores the use of AI in university library operations, focusing on digital transformation, smart, intelligent, and participatory libraries, as studied by researchers.

Garima Gujral *et al.*, (2019) AI can be utilized by librarians for reference services, teaching information literacy, monitoring, and retrieval processes. It can provide insights to collections and facilitate file storage, fostering collaborative partnerships between librarians and stakeholders.

Raykar Durga Suhas *et al.*, (2023) This paper explores the potential of artificial intelligence in library management, highlighting its transformative capabilities in automating repetitive tasks, enhancing resource discovery, personalizing user experiences, and enabling data-driven decision-making, despite the challenges posed by the increasing volume and complexity of information.

Augustine Alhaji ADEJO and Ali Yakubu MISAU (2021) Artificial Intelligence should be integrated into all academic libraries to improve efficiency and service delivery in the ICT era. Staff should be trained on AI usage, and annual budget allocation should be included for departmental training.

Subaveerapandiyan A (2023) The integration of Artificial Intelligence in libraries faces ethical and privacy concerns, necessitating careful considerations. Libraries must balance AI's benefits with human-centric values, ensuring AI complements librarians' work, and further research is needed.

Jamila Hamdan and NourEldin Osman (2022) Field studies are expanding to explore the needs of artificial intelligence technologies, focusing on their potential to provide various services and solutions for critical information retrieval systems.

Hanan Ahmed Farag *et al.*, (2021) The study recommends attending seminars and training courses on artificial intelligence for library support staff and librarians to understand and utilize these technologies, preparing the internal environment for robotics technology through financial, technical, and human support.

Oladokun, B. D., & Emmanuel, V. O. (2022). The research study highlights the importance of library use data in enabling learning analytics, enhancing future user learning journeys by providing valuable information about their behavior and service usage.

Suryakanth Halburagi and Prashant Mukarambi (2023) Artificial Intelligence simulates human intelligence in machines, performing tasks like learning, problem-solving, and decision-making. It uses algorithms, data, and machine learning to analyze complex information.

Isaiah Michael Omame and Juliet C. Alex-Nmecha (2020) The study suggests that libraries must innovate and re-examine their practices to thrive in the new knowledge economy, with artificial intelligence enhancing operations and services delivery in a digital society.

### **Challenges of Implementing Artificial Intelligence in Libraries**

Most libraries currently lack AI systems, posing challenges in implementing them in academic libraries.

1. The library staff members are reportedly lacking in technical skills and knowledge to effectively utilize and operate artificial intelligence systems.
2. The library faces constraints due to insufficient funding for the development and procurement of artificial intelligence systems due to tight hardware and software budgets.
3. The cost of developing and maintaining artificial intelligence systems in libraries is significantly high.
4. The power supply for artificial intelligence systems in libraries, particularly in developing countries, is often inadequate.
5. The article discusses the intricate aspects of enhancing expert and artificial intelligence systems.
6. Limited natural language capabilities.
7. Intelligent systems lack a common human knowledge base, which severely limits their ability to perform various functions.
8. The effort and technical expertise required to develop intelligent library systems is directly proportional to their power and complexity. However, the lack of skilled personnel and expensive development tools in academic libraries contributes to the lack of such systems.
9. Library automation vendors have limited artificial intelligence experts, necessitating hiring new personnel for comprehensive work in the complex field beyond conventional automation systems.

### **Requirements of Artificial Intelligence Technology in Academic Library**

The implementation of Artificial Intelligence technology in an academic library can improve operational efficiency and user experience, but certain requirements must be considered.

1. *Information Management:* Artificial Intelligence technology requires vast data for model training and accurate predictions, necessitating a well-organized, easily accessible database for libraries to support these applications.
2. *Robust Artificial Intelligence Infrastructure:* The design of an AI infrastructure should be tailored to meet the library's specific needs, including hardware, software, computers, and connectivity requirements.
3. *Expertise in AI Development:* Libraries require experts in artificial intelligence enhancement to build and maintain new systems, requiring expertise in programming languages, data analytics, machine learning algorithms, and related tools.
4. *Training And Quality Data maintenance:* Libraries require high-quality data sets that are current, relevant, and representative of their collections and user base to effectively train Artificial Intelligence models.
5. *Data Privacy and Security:* Libraries must implement robust data privacy and security protocols to safeguard user data and comply with data protection regulations.

6. *Artificial Intelligence Applications*: Libraries should identify specific use cases for artificial intelligence, such as automation, personalized user experiences, and recommendation engines, to enhance their library operations.
7. *Integration with Existing Library Systems*: The library needs to seamlessly integrate AI technology with its existing systems to prevent disruptions and facilitate the adoption of the new technology among staff and users.

The successful implementation of Artificial Intelligence technology in a library necessitates meticulous planning, substantial investment, and continuous support from industry experts.

### **Advantages of Artificial Intelligence**

1. Reduction of Human Error
2. Reduce the Risk (Zero risk)
3. 24/7 Support
4. Perform repetitive Jobs
5. Faster Decision
6. New Inventions
7. Digital Assistance

### **Disadvantages of Artificial Intelligence**

1. High Production cost
2. Risk of Unemployment
3. Increasing Human's laziness
4. Emotionless
5. Lack of creativity

### **Conclusion**

Artificial Intelligence technology is poised to revolutionize libraries by automating processes, enhancing user experience, and improving accessibility to information. It can provide personalized recommendations, streamline information searches, and automate tasks like cataloging and indexing. AI-powered chatbots can also assist users with common questions. Despite challenges and ethical considerations, the benefits of AI in libraries are significant.

### **References**

- [1] A. Subaveerapandiyan, (2023) "Application of Artificial Intelligence (AI) In Libraries and Its Impact on Library Operations Review" (2023). *Library Philosophy and Practice* (e-journal). 7828. <https://digitalcommons.unl.edu/libphilprac/7828>
- [2] Asemi, A., & Asemi, A. (2018). Artificial intelligence (AI) application in library systems in Iran: A taxonomy study. *Library Philosophy and Practice* (e-journal). Retrieved September 30, 2023 from: <http://digitalcommons.unl.edu/libphilprac/1840/>
- [3] Augustine Alhaji ADEJO and Ali Yakubu MISAU (2021) "Application Of Artificial Intelligence In Academic Libraries In Nigeria" (2021). *Library Philosophy and Practice* (e-journal). 6639. <https://digitalcommons.unl.edu/libphilprac/6639>
- [4] Australian Human Rights Commission. (2021). Human rights and technology. [https://tech.humanrights.gov.au/sites/default/files/2021-05/AHRC\\_RightsTech\\_2021\\_Final\\_Report.pdf](https://tech.humanrights.gov.au/sites/default/files/2021-05/AHRC_RightsTech_2021_Final_Report.pdf) [Google Scholar]
- [5] Aylin Ecem Gürsen *et al.*, (2023), "Artificial Intelligence Utilization in Libraries", *'Athens Journal of Science'*, Volume.10, Issue.2, June 2023 – Pp. 83-94
- [6] *GarimaGujral et al.*, (2019), Perceptions and Prospects of Artificial Intelligence Technologies for Academic Libraries: An Overview of Global Trends 12th International CALIBER-2019

- KIIT, Bhubaneswar, Odisha 28-30 November, 2019 INFLIBNET Centre, Gandhinagar, Gujarat
- [7] Hanan Ahmed Farag *et al.*, (2021), "Artificial Intelligence Investing in Academic Libraries: Reality and Challenges" (2021). *Library Philosophy and Practice* (e-journal). 5309. <https://digitalcommons.unl.edu/libphilprac/5309>
- [8] Heath, N. (2018). *What is AI? Everything you need to know about artificial intelligence*. Retrieved September 30, 2023 from: [www.zdnet.com/article/what-is-ai-everything-you-need-to-know-about-artificial-intelligence/](http://www.zdnet.com/article/what-is-ai-everything-you-need-to-know-about-artificial-intelligence/)
- [9] <https://www.britannica.com/technology/artificialintelligence#ref219078> (Retrieved on 02.10.2023)
- [10] IFLA Statement on Libraries and Artificial Intelligence
- [11] Irizarry-Nones, A., Palepu, A., & Wallace, M. (2017). *Artificial intelligence (AI)*. Retrieved from: [www.bu.edu/lernet/artemis/years/2017/projects/FinalPresentations/A.I.%20Presentation.pdf](http://www.bu.edu/lernet/artemis/years/2017/projects/FinalPresentations/A.I.%20Presentation.pdf)
- [12] Isaiah Michael Omame and Juliet C. Alex-Nmecha (2020) Artificial Intelligence Libraries, <https://www.researchgate.net/publication/338337072>
- [13] Jamila Hamdan and Nour Eldin Osman (2022), "The Role of Artificial Intelligence Abilities in Library Services", *The International Arab Journal of Information Technology*, Vol. 19, No. 3A, Special Issue 2022, Pp.566-573.
- [14] Kaijun Yu *et al.*, (2019) The Application of Artificial Intelligence in Smart Library, *Advances in Economics, Business and Management Research*, volume 100, International Conference of Organizational Innovation (ICOI 2019), Vol.100, Pp.708-713
- [15] McGraw-Hill Encyclopedia of Science and Technology. (2007). Artificial Intelligence. In *Encyclopedia of Science and Technology* (10th ed.; Vol. 2, pp. 228–230). New York: McGraw-Hill.
- [16] Oladokun, B. D., & Emmanuel, V. O. (2022). Machine learning and AI technologies: Gauging the implications to contemporary library services in the 21st Century Nigeria. *Nigerian Library Link*, 21(2), 44-49.
- [17] Raykar Durga Suhas *et al.*, (2023), "The use of artificial intelligence in library management", *Journal of Emerging Technologies and Innovative research*, June 2023, Volume 10, Issue 6, Pp.122-123
- [18] Robotics and AI for Customer Service Using Machine Learning: Botsandus. (2019).
- [19] Subaveerapandiyan A (2023), "Application of Artificial Intelligence (AI) In Libraries and Its Impact on Library Operations Review" (2023). *Library Philosophy and Practice* (e-journal). 7828. <https://digitalcommons.unl.edu/libphilprac/7828>
- [20] Suryakanth Halburagi and Prashant Mukarambi (2023) , "Use of Artificial Intelligence (AI) Technology Futures in Library", *International Journal of Research in Library Science (IJRLS)*, Volume 9, Issue 2 (April-June) 2023, Pp. 14-19



# Implementation of Internet of Things in Academic Libraries

S. Kamalaveni<sup>1</sup> and Dr. G. Ulaganathan<sup>2</sup>

<sup>1</sup>Research Scholar, <sup>2</sup>Research Guide, Associate Professor / Librarian & Head

<sup>1&2</sup>Department of Library and Information Science,

<sup>1&2</sup>Dr. SNS Rajalakshmi College of Arts & Sciences, Coimbatore, Tamil Nadu, India

E-mail: kamalavenimba.veni@gmail.com, drgulanathan@gmail.com

## Abstract

*Technology has significantly impacted our daily lives, fostering curiosity, creativity, and problem-solving. Its applications include artificial intelligence, cloud computing, machine learning, predictive analytics, and business intelligence tools, aiming to provide the best life for future generations. The study explores the application of Internet of Things (IoT) in libraries, focusing on its impact on building, collection management, instruction, data security, and information literacy. The study emphasizes the need for librarians to be aware of the various applications of IoT in libraries and address security issues. The aim is to improve services and increase user satisfaction by incorporating new technologies.*

**Keywords:** Internet of things; Definition; History; characteristics of Iot; Application of Iot in general and LIS

## Introduction

Electronic devices like smart phones and mobiles are integral to modern living, enabling constant internet connectivity through broadband networks and affordable WI-FI systems. These devices facilitate information access, booking, online shopping, and map navigation in daily life. The "Internet of things" includes apps, shopping sites, messengers, software, and maps. These devices save time and money, are easy to access, and can be modified by anyone. Open sources software, like Koha and D-Space, allows users to study without charge.



Fig. 1 Applications of IoT in Libraries

## Concept

A. According To By Alexander S. Gillis, Technical Writer and Editor

IoT is a network of interconnected devices, embedded with sensors and software, used in various industries for enhanced efficiency, customer service, decision-making, and business value

enhancement. It includes natural and man-made objects like heart monitors and biochips. Oct. 31, 2023, 8:41 AM ET (Yahoo News)

*B. Wiretap Snabs \$22m To Expand IoT Business Based On Distributed, Mesh Technology*

The Internet of Things (IoT) refers to the vast array of physical objects equipped with sensors and software that interact with minimal human intervention through wireless networks. It includes devices like phones, appliances, thermostats, lighting systems, security cameras, vehicles, and even animals. The Internet of Things (IoT) simplifies complex tasks, with billions of connected devices currently in use, often beyond human capabilities.

**Definition**

The Internet of Things (IoT) is a network of physical objects embedded with electronics, software, sensors, actuators, and connectivity, enabling data exchange with manufacturers, operators, and other connected devices. According To Alexander S. Gillis, IoT is a network of interconnected devices, machines, objects, animals, or people with unique identifiers, enabling data transfer without human interaction.

**History**

*A. According To By Keith D. Foote on January 14, 2022*

The Internet of Things (IoT) refers to devices with an on/off switch connected to the internet, enabling machines to communicate information over the internet. Machines have been providing direct communications since the 1830s and 1840s, with the first radio voice transmission in 1900, and computers began in the 1950s..The internet, a crucial component of the Internet of Things (IoT), originated from DARPA in 1962 and evolved into ARPANET in 1969.

In the 1980s, commercial service providers facilitated ARPANET's evolution into the modern Internet, with satellites and landlines serving as fundamental communications for IoT.

In 1993, the Department of Defense established a stable GPS system, followed by commercial satellites, enhancing the IIoT's functionality.

**Review of Literature**

Muhamad and Darwesh (2020), A library model using IoT and RFID technology improves library services across various sections. It classifies reference services, generates theft alarms, manages circulation time, and provides GSM navigation for due date tracking and user privacy.

Devi, Mirudhula and Devi (2021) proposed and designed advanced library management system using RFID technology for book circulation and reduce manpower.

Li (2021) The researcher developed an intelligent IoT-based e-book retrieval system for university libraries, addressing challenges with limited network licenses and semantic similarity. Smart context sensors provide feedback and situational awareness technology.

Maepa and Moeti (2021) Tshwane University of Technology developed an IoT-based smart library seat occupancy and reservation prototype using RFID and FSR technologies. The web application allows users to monitor occupancy and reserve seats using different colors.

Karthikeyan *et al.*, (2021) The study developed an optical character recognition (OCR) algorithm for book text reorganization, detecting the book's exact location using an ultrasonic sensor. The

scanned text is processed by a Raspberry Pi, converting it into an audio file and aiding visually challenged individuals.

Jianning Qin, (2018) The Internet of Things (IoT) is a crucial technology in logistics, processes, and workflow organizations, improving organizational structures and enabling real-time monitoring and optimization of processes. It has been reported to create new business models, particularly in the global trend of providing all goods as a service.

Jignesh makwana, (2021) IoT, or the Internet of Things, is a vast network of connected objects that captures data about usage and environment. It is closely related to libraries, providing global connectivity and enabling them to function more efficiently and smartly. IoT libraries can find patterns and gather information, making them more relevant and useful in today's modern library environment.

Sheeja N K, (2019) Researchers suggest IoT applications in libraries can track materials, promote self-check-outs, provide consulting, training, information sharing, and enhance library marketing, highlighting the infinite possibilities of IoT in library applications.

Satish Kumar, (2016) Library management is an important aspect of IOT technology. Although most libraries have adopted bar code recognition, computer networks, computer software and other modern management and technology, there are still many problems for the library staff.

Hafijull Mondal, (2021) The Internet of Things (IoT) is a network of interconnected devices that collect and transfer data wirelessly, enabling automation in various forms of buildings. IoT devices monitor and control mechanical, electrical, and electronic systems, making everyday objects smart and requiring no manual intervention.

### **Statement of the Problem**

*The Topic of a Current Research Article is given below*

1. Use of Internet of Things (IoT)
2. Applications in academic library activities and services

### **Objective of Study**

1. To identify the basics concepts of the Internet of Things (IoT) and its structure.
2. To identify the definition of IoT
3. To identify the history of IoT
4. To furnish an overview of IoT
5. To identify the various possibilities of IoT applications in the library.
6. Advantages of IoT system
7. Disadvantages of IoT system

### **Scope and Limitation of the Study**

Library types include public, academic, special, and sub-types, with various users. Library users aim for information tailored to their scope with precision, speed, and low cost. Traditional libraries struggle, while smart libraries use computer, network, and internet technology. This article discusses the activity and service of academic libraries, focusing on IoT applications.

### Signification of the Study

Information is now a commodity that can be sold, replacing farming and industry as means of livelihood. Professionals like doctors, lawyers, teachers, and engineers rely on information for their success. Libraries are unique organizations for collecting and disseminating information, and understanding modern technology tools is essential for their continuous creation, collection, dissemination, and retrieval. This study highlights the significance of information in today's society.

### Characteristics of IoT

Retrieved from <https://datatrained.com/post/characteristics-of-iot/> on 30.11.2023

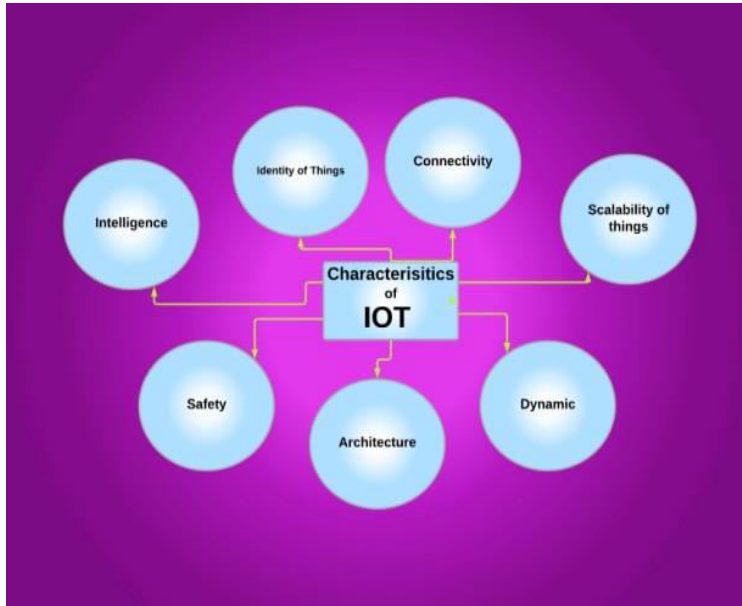

Fig.2 Characteristics of IoT

#### A. Connectivity

IoT connects devices, enabling communication, sharing of information, and remote control of objects, creating a connected world where everything is interconnected and user data is shared.

#### B. Identity of Things

Identity is a unique characteristic of individuals, such as the unique IMEI number on mobile phones, which helps identify people and things on the Internet identity is a crucial concept in IoT, defining the uniqueness and control of devices by providing a unique name and allowing them to be distinguished.

#### C. Scalability

Scalability is crucial for IoT systems, allowing them to grow without affecting performance by adding more hardware or software layers.

#### D. Dynamic or Self-Adapting

IoT's dynamic nature necessitates self-adaptability to adapt to changes, as seen in the camera's ability to adjust its quality based on light, a crucial characteristic for system growth and self-adaptability.

### *F. Safety*

IoT connects everything to the internet, simplifying user experiences, but also poses risks to sensitive personal details, making safety a crucial characteristic.

### *G. Intelligence*

The evolution of digital personal assistants like Alexa, Cortana, and Siri exemplifies the intelligence of electronic devices, while IoT devices, consisting of smart sensors and devices, require constant updates to ensure their functionality and accuracy.

### **Application of IoT in Generally**

1. Smart Home
2. Wearable's
3. Connected Cars/smart Cars
4. Smart Industry
5. Smart Cities
6. Smart Agriculture
7. Smart Retail
8. Energy Management
9. Smart Healthcare
10. Smart Poultry and Farming
11. Smart Dust

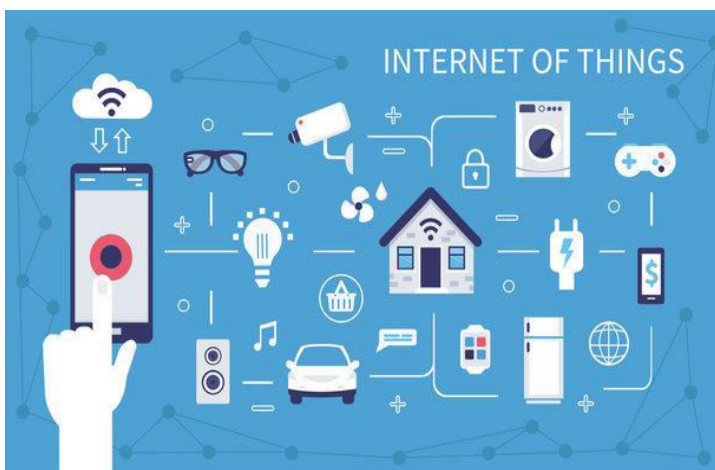

Fig.3 Applications of IoT in Libraries

### **Application in Library Services**

Most prominent applications derived from the literature reviewed are listed below:

#### *1. Smart Infrastructure*

Internet of Things -based library buildings use sensors to monitor operations, optimize lighting, cooling, heating, and fire protection. They provide a clean, comfortable learning environment, with intelligent fire and security systems. IoT technology collects data on resource usage, building suitability, restroom cleanliness, and furniture movement. It also allows users to know access to cubicles, desktops, and printers, aiding in strategic space management decisions.

## 2. Services and Facilities

IoT enables libraries to offer personalized services, providing contextual hints, information about resources, mobile applications integration, communication about new additions, account status, events, and catalog searches, current awareness services, enhancing user experience.

## 3. Locating Books and Other Reading Materials

IoT enhances library services by providing contextual hints, resource information, mobile app integration, new additions communication, account status updates, events, and catalog searches.

## 4. Library Orientation and Information Literacy Program

The library orientation programmer uses IoT applications to familiarize new members with library resources, services, and facilities, enabling librarians to teach users about services through mobile apps, virtual tours, and video content exploration.

## 5. Modern Circulation System

The library is implementing an IoT system using Android-based UHF mobile readers to manage materials, alert users about holdings, overdue dates, and fine details.

## 6. Stock Verification System

Library resources can be controlled using sensors and IoT, enabling easy traceability of misplaced materials. UHF RFID tags on shelf materials allow Android mobile readers to view a detailed list, reducing stock verification time and misplaced books.

## Conclusion

The article highlights the increasing demand for IoT applications in library activities, highlighting its benefits in saving time, energy, and money while maximizing resource utilization. IoT technology offers sustainable information development practices in the knowledge society. However, challenges like security, privacy, and standardization hinder its adoption in libraries. Librarians must collaborate to enhance services and facilities, utilizing IoT technologies in various services.

## References

- [1] Anita L. Deshpande. (2022) Usages of IOT in Smart Library, *International Journal of Innovative Science and Research Technology*, (7)9, 405-407
- [2] Archana Saxena(2016)Impact of mobile technology on libraries: a descriptive study, *International Journal of Digital Library Services*, (3)4, Pp1-58
- [3] Bansal, Alka; Arora, Dipti; and Suri, Alka, (2018) "Internet of Things: Beginning of New Era for Libraries" (2018). *Library Philosophy and Practice (e-journal)*. 2081. <http://digitalcommons.unl.edu/libphilprac/2081>
- [4] Based on internet of things. *UHD Journal of Science and Technology*, 4(2), 63–74. <https://doi.org/10.21928/uhdjst.v4n2y2020.pp63-74>
- [5] Bindu K (2021) Internet of things (iot) and academic libraries, *JETIR* May 2021, (8)5, 1745-1747
- [6] Hafijull Mondal(2021), Application of IOT in Library, *International Journal of Research Publication and Reviews*, (2)3, 2021 Pp 5-11
- [7] [https://csrc.nist.gov/glossary/term/internet\\_of\\_things\\_IoT](https://csrc.nist.gov/glossary/term/internet_of_things_IoT)
- [8] <https://www.britannica.com/science/Internet-of-Things>
- [9] <https://www.dataversity.net/brief-history-internet-things/>
- [10] <https://www.rtsrl.eu/blog/what-is-internet-of-things-iot/>

- [11] <https://www.techtarget.com/iotagenda/definition/Internet-of-Things-IoT>
- [12] Jeeva Jose. (2023) Internet of things, Khanna Book publishing, Rs.399/-, 978 93-86173-59-1, Pp.1-350
- [13] Jianning Qin,(2021)The Research of the Library Services Based on Internet of Things, *Advances in Social Science, Education and Humanities Research*, (89), 421-420.
- [14] Karthikeyan, D., P., A. V, Surendhirababu, K., Selvakumar, K., Divya, P., Suhasini, P., & Palanisamy, R. (2021). Sophisticated and modernized library running system with OCR algorithm using IoT. *Indonesian Journal of Electrical Engineering and Computer Science*, 24(3), 1680. <https://doi.org/10.11591/ijeecs.v24.i3.pp1680-1691>.
- [15] Kennedy Arebamen Eiriemiokhale and Jam, Bukola Olutola, (2023)Application of the Internet of Things for Quality Service Delivery in Nigerian University Libraries, *Indian Journal of Information Sources and Services*, Vol.13, No.1, 2023, pp.17-25, DOI: <https://doi.org/10.51983/ijiss-2023.13.1.3463>
- [16] Maepa, M. R., & Moeti, M. N. (2021). Iot-based smart library seat occupancy and reservation system using rfid and fsr technologies for south african universities of Priyanka Sinha and Dr. Khushpreet Singh Brar
- [17] Mahdi Mohammadi, Mehri Ezadi Yegane(2021)How can We Equip Academic Libraries with IOT Technologies: Practical Guidelines, *International Journal of Digital Content Management*,(2)2Winter &spring 2021
- [18] Makori, E.O. (2017). Promoting innovation and application of internet of things in academic and research information organizations. *Library review*, 66(8/9), 655-678.
- [19] Makwana, jignesh, "Use of Internet of Things (IoT) Applications in Modern Library Activities and Services" (2021). *Library Philosophy and Practice* (e-journal). 6693. <https://digitalcommons.unl.edu/libphilprac/6693>
- [20] Mrs Ashwini Nag (2016) Internet Of Things Applications In Academic Libraries, *International Journal of Information Technology and Library Science*, (5)1, Pp1-7
- [21] Muhamad, S. S., & Darwesh, A. M. (2020). Smart university library management system
- [22] Priyanka Sinha1 (2022) Application of Internet of Things (IoT) in Libraries, <https://www.researchgate.net/publication/362544831>
- [23] Rajender Kumar (2023)Students' Perspectives on the Application of Internet of Things for Redesigning Library Services at Kurukshetra University, from the journal Open Information Science <https://doi.org/10.1515/opis-2022-0154>,
- [24] Rupali D. Bhure (2018)Application of internet of things in secured library management system, *International Research Journal of Engineering and Technology (IRJET)*,(5)4 Apr-2018, Pp 2064-2066
- [25] Rutwik Ananda kolhe1 et. Al, (2020)Smart library management system using iot, international journal of advance scientific research and engineering trends, (4)12 ICCEME 2019-2020, ISSN (Online) 2456-0774
- [26] Satish Kumar,(2016)Application of 'Internet of Things' (IoT) Technology in Library Management & Services, *International Journal of Scientific & Innovative Research Studies*, Vol (4), Issue-2,February -2016,Pp 1-7
- [27] Sheeja N K(2019)Internet of Things (IoT) in Academic Libraries,Pp45-51
- [28] Suresh C Jakati, Kiran Kumar G(2022),Impact of the internet of things (IOT) on academic libraries and its users, *International Journal of Multidisciplinary Research and Development*, (9) 8, 2022, Page No. 25-28.

# The Mobile Knowledge Exchange: Exploring Student Attitudes and Perceptions of Mobile-Mediated Knowledge Sharing: A Study at St. Joseph Engineering College, Mangalore, Karnataka, India

**Dr. Dayanandappa Kori**

Information Scientist Dr Hari Singh Gour Central University Sagar, Madhya Pradesh, India

E-mail: koridh@gmail.com

## **Abstract**

*This study explores the attitude of students towards knowledge sharing through mobile phone technology at St. Joseph Engineering College, Mangalore. As mobile phones have become increasingly prevalent in educational settings, it is crucial to understand students' perceptions and preferences regarding the use of this technology for sharing knowledge. Quantitative research methods were employed, and a structured questionnaire was used as the primary data collection tool. The questionnaire was distributed to a sample of students from various departments of the engineering college. The collected data were analyzed using descriptive and inferential statistics to gain insights into students' attitudes towards knowledge sharing through mobile phone technology. The findings of the study indicate that the majority of students at St. Joseph Engineering College, Mangalore, hold a positive attitude towards knowledge sharing through mobile phone technology. They recognize the potential benefits of using mobile phones as a means of accessing and sharing educational resources, collaborating with peers, and staying updated with relevant information. Factors such as perceived usefulness, ease of use, and social norms were found to influence students' attitudes towards mobile-based knowledge sharing. These results have significant implications for educational institutions, policymakers, and educators seeking to leverage mobile phone technology for knowledge sharing purposes. By understanding students' attitudes and preferences, educators can design effective strategies and interventions that align with students' needs.*

**Keywords:** Attitude of Students, Knowledge Sharing, Quantitative Research Methods.

## **Introduction**

Knowledge sharing plays a vital role in the learning process and the acquisition of knowledge. With the rapid advancements in technology, mobile phone technology has emerged as a powerful tool for knowledge sharing among students. This study aims to explore students' attitudes towards knowledge sharing through mobile phone technology at St Joseph Engineering College in Mangaluru.

## **Literature Review**

Previous studies have explored the attitudes of students towards knowledge sharing through mobile phone technology in various educational settings. Gikas and Grant (2013) conducted a study on undergraduate students and found that mobile technology, such as smartphones and tablets, facilitated knowledge sharing and collaborative learning. Students reported positive attitudes towards using mobile devices for sharing information, accessing educational resources, and collaborating with peers. Al-Emran *et al.*, (2016) investigated the attitude of university students towards using mobile devices for knowledge sharing. The study revealed that students perceived mobile technology as an effective tool for accessing information, engaging in collaborative activities, and sharing knowledge. They also reported increased motivation and convenience in accessing learning materials through mobile devices. In a study by Weng *et al.*,



(2017) on medical students, it was found that mobile technology enhanced knowledge sharing and communication among students. Students expressed positive attitudes towards using mobile devices for accessing medical resources, discussing case studies, and collaborating on research projects. Chen *et al.*, (2019) conducted research on engineering students and found that mobile technology supported knowledge sharing and collaborative learning. Students perceived mobile devices as useful tools for accessing course materials, discussing academic topics, and participating in group projects. According to a study by Khan *et al.*, (2020) on university students, mobile technology facilitated knowledge sharing and interaction among students. Students reported positive attitudes towards using mobile devices for accessing educational content, participating in online discussions, and seeking help from peers. These previous studies indicate that students generally have positive attitudes towards knowledge sharing through mobile phone technology. Mobile devices are perceived as convenient tools for accessing information, collaborating with peers, and enhancing the learning experience. However, it's important to note that these findings may vary across different educational contexts and student populations. Conducting a study specific to St Joseph Engineering College Mangaluru would provide valuable insights into the attitudes of students at that particular institution.

### Methodology

To achieve the research objectives a survey questionnaire will be administered to a sample of students from St Joseph Engineering College to collect quantitative data on their attitudes towards mobile-based knowledge sharing.

### Research Objectives

1. To examine students' attitudes towards knowledge sharing through mobile phone technology.
2. To identify the factors that influence students' engagement in mobile-based knowledge sharing activities.
3. To explore the perceived benefits and challenges of utilizing mobile phone technology for knowledge sharing.
4. To provide insights and recommendations for educational institutions to facilitate effective mobile-based knowledge sharing practices.

TABLE I GENDER OF THE RESPONDENTS

S. No.	Gender	Respondents
1	Male	41 (49.4%)
2	Female	42 (50.6%)
Total		83 (100%)

The table I provides information about the genders of the survey respondents. Out of 83 respondents, 42 (50.6%) were female, while 41 (49.4%) were male. The study had a relatively balanced distribution of respondents based on gender, with a slight majority of female participants.

The table II shows the academics perceived, Based on the analysis of the attitudes towards mobile phone technology presented in Table II, the following observations can be made: Using Mobile Phone Technology Is/might be an excellent idea: The majority of respondents (31.3%) mostly agree with this statement, followed by 26.5% who slightly agree. On the other hand, only 6.0% completely disagree with this idea. Using Mobile Phone Technology is/might be a pleasant experience: Similar to the previous statement, the majority (28.9%) mostly agree that using mobile phone technology is a pleasant experience. However, there is a slightly higher percentage of respondents (14.5%) who slightly disagree compared to the previous statement. Using Mobile

Phone Technology is/might be beneficial to me: In this case, the majority (37.3%) mostly agree that using mobile phone technology is beneficial to them. The percentage of respondents who completely agree (12.0%) is slightly lower compared to the previous statements. Using Mobile Phone Technology increases my knowledge in my field: The majority of respondents (28.9%) mostly agree that mobile phone technology increases their knowledge in their respective fields.

TABLE II ACADEMICS PERCEIVED

S. No.	Attitudes	Completely Agree	Mostly Agree	Slightly Agree	Slightly Disagree	Mostly Disagree	Completely Disagree
1	Using Mobile Phone Technology Is/might be an excellent idea.	10 (12.0%)	26 (31.3%)	22 (26.5%)	11 (13.3%)	9 (10.8%)	5 (6.0%)
2	Using Mobile Phone Technology is/might be a pleasant experience	11 (13.3%)	24 (28.9%)	21 (25.3%)	12 (14.5%)	7 (8.4%)	8 (9.6%)
3	Using Mobile Phone Technology is/might be beneficial to me	10 (12.0%)	31 (37.3%)	20 (24.1%)	9 (10.8%)	6 (7.2%)	7 (8.4%)
4	Using mobile Phone technology increases my knowledge in my field	15 (18.1%)	24 (28.9%)	20 (24.1%)	12 (14.5%)	7 (8.4%)	5 (6.0%)
5	Using mobile Phone technology increases my motivation towards study	8 (9.6%)	17 (20.5%)	21 (25.3%)	18 (21.7%)	11 (13.3%)	8 (9.6%)
6	Using mobile Phone technology Increases my communicate on with classmates.	23 (27.7%)	26 (31.3%)	22 (26.5%)	5 (6.0%)	2 (2.4%)	5 (6.0%)
7	Using Mobile Phone Technology enables me to do my work conveniently.	16 (19.3%)	29 (34.9%)	21 (25.3%)	8 (9.6%)	2 (2.4%)	7 (8.4%)
8	Using Mobile Phone Technology can increase my productivity	13 (15.7%)	21 (25.3%)	27 (32.5%)	9 (10.8%)	8 (9.6%)	5 (6.0%)
9	Using Mobile Phone Technology can improve my efficiency in my daily work	13 (15.7%)	20 (24.1%)	26 (31.3%)	12 (14.5%)	4 (4.8%)	8 (9.6%)
10	Using Mobile Phone Technology can save me a lot of time in general.	17 (20.5%)	22 (26.5%)	25 (30.1%)	9 (10.8%)	7 (8.4%)	3 (3.6%)
11	Using Mobile Phone Technology can enhance my effectiveness in carrying out my daily	14 (16.9%)	26 (31.3%)	22 (26.5%)	12 (14.5%)	5 (6.0%)	4 (4.8%)

However, there is a significant proportion (14.5%) who slightly disagree with this statement. Using Mobile Phone Technology increases my motivation towards study: The majority (25.3%) slightly agree that mobile phone technology increases their motivation towards study. However, there is also a considerable percentage (21.7%) who slightly disagree with this statement. Using Mobile Phone Technology increases my communication with classmates: The majority (31.3%) mostly agree that mobile phone technology increases their communication with classmates. Only a small percentage (2.4%) mostly disagree with this statement. Using Mobile Phone Technology enables me to do my work conveniently:

The majority (34.9%) mostly agree that mobile phone technology enables them to do their work conveniently. However, there is a small proportion (2.4%) who mostly disagree with this statement. Using Mobile Phone Technology can increase my productivity: The majority (32.5%) slightly agree that mobile phone technology can increase their productivity. The percentage of respondents who completely agree (15.7%) is lower compared to the previous statements. Using Mobile Phone Technology can improve my efficiency in my daily work: Similar to the previous statement, the majority (31.3%) slightly agree that mobile phone technology can improve their

efficiency in daily work. Using Mobile Phone Technology can save me a lot of time in general: The majority (30.1%) slightly agree that mobile phone technology can save them a lot of time. The percentage of respondents who completely agree (20.5%) is relatively high compared to other statements. Using Mobile Phone Technology can enhance my effectiveness in carrying out my daily work: The majority (31.3%) slightly agree that mobile phone technology can enhance their effectiveness in daily work. It is important to note that the respondents' attitudes vary across different statements, indicating a diverse range of perceptions towards the use of mobile phone technology among academics.

TABLE III ACADEMICS' PERCEIVED USEFULNESS

S. No.	Attitudes	Agree Strongly	Agree Moderately	Agree Slightly	Disagree Slightly	Disagree Moderately	Disagree Strongly
1	Mobile Learning tools help accomplish task more quickly	17 (20.5%)	36 (43.4%)	20 (24.1%)	7 (8.4%)	1 (1.2%)	2 (2.4%)
2	Mobile Learning increase academic performance	15 (18.1%)	23 (27.7%)	16 (19.3%)	13 (15.7%)	4 (4.8%)	12 (14.5%)
3	Use of Mobile Learning resulted in increase productivity	14 (16.9%)	26 (31.3%)	17 (20.5%)	12 (14.5%)	7 (8.4%)	7 (8.4%)
4	Use of Mobile Learning will increase effectiveness	15 (18.1%)	21 (25.3%)	20 (24.1%)	13 (15.7%)	7 (8.4%)	7 (8.4%)
5	Mobile Learning makes learning easier	15 (18.1%)	27 (32.5%)	16 (19.3%)	10 (12.0%)	7 (8.4%)	8 (9.6%)
6	Mobile Learning is useful for learners	16 (19.3%)	26 (31.3%)	20 (24.1%)	7 (8.4%)	8 (9.6%)	6 (7.2%)
7	It is easy to access information from Mobile Learning	22 (26.5%)	28 (33.7%)	21 (25.3%)	5 (6.0%)	3 (3.6%)	4 (4.8%)
8	It is easy to use Mobile Learning tools to communicate with colleagues	26 (31.3%)	30 (36.1%)	16 (19.3%)	3 (3.6%)	3 (3.6%)	5 (6.0%)
9	It is easy to become skillful at using Mobile Learning	23 (27.7%)	25 (30.1%)	14 (16.9%)	10 (12.0%)	5 (6.0%)	6 (7.2%)
10	I can use Mobile Learning to communicate and share knowledge with colleagues/ friends in class often	20 (24.1%)	37 (44.6%)	12 (14.5%)	5 (6.0%)	5 (6.0%)	4 (4.8%)
11	I use Mobile Learning to communicate with the instructor often	16 (19.3%)	33 (39.8%)	17 (20.5%)	5 (6.0%)	10 (12.0%)	2 (2.4%)
12	I always use Mobile Learning to interact with my learning	14 (16.9%)	31 (37.3%)	19 (22.9%)	10 (12.0%)	5 (6.0%)	4 (4.8%)
13	Mobile Learning use for sharing knowledge with friends	19 (22.9%)	36 (43.4%)	15 (18.1%)	5 (6.0%)	4 (4.8%)	4 (4.8%)
14	Mobile Learning help learners to create knowledge	19 (22.9%)	31 (37.3%)	14 (16.9%)	8 (9.6%)	8 (9.6%)	3 (3.6%)

The table III shows the academics' perceived usefulness, based on the analysis of the attitudes towards mobile phone technology presented in table, the following observations can be made: Positive Perception: Overall, respondents showed a positive perception of mobile learning technology. For most statements, the majority of respondents either agreed moderately or agreed strongly, indicating that they find mobile learning tools and technology useful and beneficial. Task Accomplishment and Academic Performance: Respondents particularly expressed strong agreement that mobile learning tools help them accomplish tasks more quickly and that mobile learning can increase academic performance. This suggests that they see mobile learning as a valuable aid for their academic endeavors. Productivity and Effectiveness: A significant number of respondents agreed moderately that mobile learning resulted in increased productivity and would

increase the effectiveness of their learning. This demonstrates that they believe mobile learning can positively impact their learning outcomes and performance. Ease of Use and Communication: Respondents generally found mobile learning tools easy to use and felt confident in communicating with colleagues or instructors through these platforms. This indicates that the user-friendliness and communication features of mobile learning were positively received. Sharing Knowledge and Creating Knowledge: A considerable proportion of respondents agreed moderately that mobile learning facilitates sharing knowledge with friends and helps learners create knowledge. This suggests that they see mobile learning as a collaborative and knowledge-building tool. Varied Levels of Agreement: While the majority of respondents tended to agree with the statements, there were varying levels of agreement. Some statements had higher agreement percentages, while others had relatively lower agreement percentages, indicating that respondents had different levels of acceptance for different aspects of mobile learning. Minimal Disagreement: In general, there was minimal disagreement with the statements. Disagreement was more pronounced in some statements, but it was relatively low compared to the overall positive attitudes expressed.

## Findings

1. *Socio-Demographic Profile*: Table I provides information about the socio-demographic profile of the respondents. This table helps to understand the characteristics of the participants in the study and provides a context for interpreting their attitudes towards mobile phone technology.

2. *Attitudes towards Mobile Phone Technology*: Table II presents the respondents' attitudes towards mobile phone technology, focusing on factors such as perceived usefulness, perceived ease of use, and attitudes towards mobile learning. It provides a comprehensive overview of the attitudes and opinions of the participants towards mobile phone technology in education. The table includes statements related to the advantages and disadvantages of mobile learning, as well as the respondents' level of agreement or disagreement with each statement.

3. *Academics' Perceived Usefulness*: Table III specifically focuses on the academics' perceived usefulness of mobile learning tools and their impact on various aspects of academic performance and productivity. It presents a detailed breakdown of the respondents' agreement or disagreement with statements related to the usefulness of mobile learning tools in accomplishing tasks, improving academic performance, increasing productivity, and facilitating communication and knowledge sharing. These tables collectively provide insights into the attitudes, perceptions, and beliefs of academics towards mobile phone technology in education. They offer valuable information about the benefits and challenges associated with mobile learning, as well as the overall acceptance and utility of mobile phone technology among the respondents. The data presented in these tables can guide further analysis and discussions related to the integration and effectiveness of mobile learning in academic settings.

## Suggestions

Based on the analysis of attitudes towards mobile phone technology, the following suggestions can be made:

1. *Training and Professional Development*: Provide training and professional development opportunities for academics to enhance their skills and knowledge in utilizing mobile learning tools effectively. This can help address any concerns or challenges they may have and increase their confidence in incorporating mobile technology into their teaching practices.
2. *Pedagogical Integration*: Emphasize the pedagogical integration of mobile learning tools rather than focusing solely on the technology itself. Educators should be encouraged to explore innovative instructional strategies and learning activities that leverage the unique

features of mobile devices to enhance student engagement, collaboration, and critical thinking.

3. *Addressing Concerns*: Take into account the concerns expressed by academics regarding distractions and reduced face-to-face interaction. Design guidelines and best practices that help educators strike a balance between mobile technology use and traditional teaching approaches. This can include setting clear expectations for device use, incorporating collaborative activities that encourage interaction, and integrating mobile tools purposefully into the curriculum.
4. *Research and Evaluation*: Encourage further research and evaluation of mobile learning initiatives to gather more evidence on their impact and effectiveness. This can help build a strong evidence base that supports the integration of mobile technology in education and informs best practices.
5. *Collaboration and Sharing*: Promote collaboration and knowledge sharing among academics regarding their experiences and best practices in using mobile learning tools. This can be facilitated through online communities, conferences, or workshops where educators can exchange ideas, resources, and lessons learned.
6. *Accessibility and Digital Equity*: Ensure that mobile learning initiatives take into consideration issues of accessibility and digital equity. Recognize that not all students may have equal access to mobile devices or reliable internet connectivity. Develop strategies to mitigate these disparities and provide support to students who may not have access to their own devices.
7. *Ongoing Support*: Provide ongoing technical support and assistance to academics in the effective use of mobile learning tools. This can include help desks, online resources, and peer mentoring programs to address any challenges or technical issues that may arise.

By implementing these suggestions, educational institutions can create a supportive environment for academics to embrace mobile learning and harness its potential for enhancing teaching and learning experiences.

## **Discussion and Conclusion**

The analysis of attitudes towards mobile phone technology, as presented in Tables I, II, and III, provides valuable insights into the perceptions and opinions of academics regarding the use of mobile learning tools in education. The following discussion and conclusion can be drawn from the findings: **Positive Perception of Mobile Learning**: The data from Tables II and III indicates a generally positive perception of mobile learning among academics. The majority of respondents agreed that mobile learning tools are useful, increase productivity, make learning easier, and are beneficial for learners. This suggests that academics recognize the potential of mobile technology in enhancing educational practices and improving student outcomes. **Perceived Benefits of Mobile Learning**: The analysis of table reveals that respondents acknowledged the advantages of mobile learning, including its flexibility, accessibility to information, and potential for enhancing student engagement and learning outcomes. These positive perceptions align with the growing body of research highlighting the benefits of mobile technology in education, such as promoting active learning, personalized instruction, and real-time access to resources. **Concerns and Disadvantages**: While the overall attitude towards mobile learning was positive, there were also concerns and disadvantages expressed by the respondents. The data from table indicates that a notable percentage of academics expressed concerns about mobile learning being distracting and potentially reducing face-to-face interaction. These concerns highlight the need for careful implementation strategies that address these issues and maintain a balance between technology integration and traditional teaching approaches. **Acceptance and Use of Mobile Learning**: The findings from table suggest a relatively high acceptance and use of mobile learning among

academics. Respondents reported using mobile learning tools for various purposes, such as communication, knowledge sharing, and interaction with instructors and peers. This indicates that academics are actively engaging with mobile technology to facilitate teaching and learning processes. Based on the analysis of the data, it can be concluded that academics generally perceive mobile learning as a valuable tool in education. They recognize its potential benefits in terms of productivity, learning enhancement, and knowledge sharing. However, concerns regarding distractions and reduced interpersonal interactions should be addressed to ensure effective integration of mobile technology in educational settings. Overall, the findings emphasize the importance of considering academics' attitudes and concerns when designing and implementing mobile learning initiatives. Strategies should be developed to maximize the benefits of mobile technology while addressing potential challenges. Further research and professional development opportunities can contribute to enhancing educators' confidence and competence in utilizing mobile learning tools effectively.

## References

- [1] Al-Emran, M., Mezhuyev, V., Kamaludin, A., & Shaalan, K. (2016). Students' attitudes towards using mobile devices for learning: A case study in a Gulf country. *International Journal of Interactive Mobile Technologies*, 10(2), 4-10. <https://doi.org/10.3991/ijim.v10i2.5579>
- [2] Chen, C. H., Wang, M. H., & Chen, Y. L. (2019). College students' attitudes and self-efficacy toward the use of mobile devices for English listening exercises. *International Journal of Distance Education Technologies*, 17(2), 52-64. <https://doi.org/10.4018/IJDET.2019040104>
- [3] Gikas, J., & Grant, M. M. (2013). Mobile computing devices in higher education: Student perspectives on learning with cellphones, smartphones & social media. *Internet and Higher Education*, 19, 18-26. <https://doi.org/10.1016/j.iheduc.2013.06.002>
- [4] Khan, I. A., Mahmood, S., & Ullah, S. (2020). Influence of smartphones on higher education: Students' perspective. *Education and Information Technologies*, 25(4), 3385-3401. <https://doi.org/10.1007/s10639-020-10249-7>
- [5] Weng, C. H., Hsieh, Y. J., Shih, Y. H., Kuo, K. M., & Huang, H. L. (2017). How medical students' attitudes towards the learning of anatomy in a flipped classroom can be influenced by the design of online materials. *BMC Medical Education*, 17(1), 115. <https://doi.org/10.1186/s12909-017-0958-6>

# Evaluation of Library Circulation Services in Engineering Colleges in Hyderabad and Ranga Reddy Districts: A Study

**Dr. Kumara Swamy Reddy Kothapati**

Librarian, Sri Venkateswara College of Engineering, Andhra Pradesh, Tirupati, India

E-mail: kumarlibrary@gmail.com

## **Abstract**

*This study examines the evaluation of library circulation services of engineering colleges in Hyderabad and Ranga Reddy Districts. A total of 23 library professional's responses were collected and analyzed. The result shows that majority of the libraries (78.26%) are not working on holidays. The majority of the libraries (69.57%) are using computerized system for issue and return of documents, most of the libraries (95.65%) the documents are issued and returned on all the working days in a week. All the twenty-three libraries (100.00%) under three categories viz., private non-minority, private minority and government, are following open access system in all the wings of their libraries for the benefit of users.*

**Keywords:** Evaluation, Circulation, Engineering Colleges.

## **Introduction**

Libraries are said to be the backbone of any organization to which they are attached. They are supposed to provide appropriate information to its users in time. In any library, circulation section deals with borrowing and returning of library materials, collection of overdue charges and generation of statistics relating to circulation of documents to different groups of users. The information desires of the users of libraries whether they are academic college or the engineering colleges have also become complex and challenging due to the tremendous publications and interdisciplinary explores that are being promoted at the level of higher education. The librarians working in these institutions need to pay honest attention to obtain appropriate and need based literature in these subjects to the utmost satisfaction of their academic staff and students. In this critical situation, librarians should have a clear understanding of their users' needs and their information seeking behavior so that the libraries can satisfy the user needs as well as improve the prevailing services accordingly.

## **Relevant Literature**

Suryanarayana and Hugar (1988)<sup>1</sup> described the preliminary plan for an automated circulation system based on the experience gained in the library of IIT, Bombay. Sharma (2001)<sup>2</sup> conducted a survey on engineering college libraries in Haryana using questionnaire method. Ninety per cent of the libraries are kept open for eight hours a day to suit the college working hours. Majority of the libraries (70%) had open access and 65% were using Browne charging system for circulation. A high percentage of the libraries (55%) had computer system and 82% of them were using computer for acquisition purpose.

Dinkins (2003)<sup>3</sup> found that at Stetson University, circulation patterns varied by subject area and were also affected by whether books were selected by librarians or department faculty. Music books selected by librarians had the highest proportional circulation: 39% of books accounted for 80% of circulation. Knievel *et al.*, (2006)<sup>4</sup> urge librarians to use detailed circulation data and statistics to inform "evidence-based decision making" in this era of decreasing library budgets. Chinna Balu (2011)<sup>5</sup> conducted a survey of twenty-nine engineering college libraries and their users in Sri Venkateshwara University area of Andhra Pradesh. The data was collected from twenty-nine librarians and 1,853 users of engineering colleges with the help of a questionnaire.

The findings of the study are: majority of the users (66.7%) are visiting the library regularly and majority of them (59.2%) visit the library to borrow books; nearly half of the users (48.6%) are spending one hour in the library; most of the users (96.9%) are satisfied with the working of the library on working days; majority of users are satisfied with the reference service, circulation service, and document reservation facility; most of the users (81.4%) are satisfied with reading space and furniture; and most percentage of users (86.5%) are satisfied with efficiency of the library staff. Tayewo Olayinka (2013)<sup>6</sup> Circulation of Library materials are central and imperative in every Library operation. This study aspects into the activities that make up circulation of Library materials, and discusses the processes and procedures for the registration of Library clientele, charging and discharging services. The study reviewed how this has impacted on the Circulation services in the library noting the advantages. Concludes that circulation activities reflect, compliment and promote the services and image of the library and need to be given priority attention and manned by competent staff.

G.Veena and Prabhakara Narasimha Kotari (2016)<sup>7</sup> examine the user's satisfaction in library facilities, resources and services of the students of SDM College Library, Ujire. 300 questionnaires were distributed among students to collect relevant data. The findings of the study showed that 177(59.0%) of respondents have the habit to visit to the library daily, majority 210 (70.0%) are highly satisfied with collection of text books 160 (53.3%) respondents considered circulation services as excellent. The study suggested that college library should carry out user studies at regular intervals, in order to identify user's information needs and their information gathering behaviors.

### **Objectives of the Present Study**

1. To know the working hours on working days and holidays;
2. To know the circulation services of selected engineering college libraries;
3. To know the different sections in the selected engineering college libraries;

### **Scope and Limitations**

The study is primarily concerned with libraries of engineering colleges functioning within the territorial jurisdiction of the Hyderabad and Ranga Reddy districts in Telangana. There are about 186 engineering colleges in the study area and out of them 23 engineering colleges were established in the year 2000 or before. The present study is limited to 23 engineering colleges which were established in the year 2000 or before. The main criterion for selection of twenty-three engineering colleges in this study is that colleges which are of recent origin are not ideal for inclusion in the sample due to the fact that these colleges may not have well established library collection, services, physical as well as information communication technology infrastructure. Besides, eighteen colleges out of the twenty-three selected engineering colleges are offering postgraduate courses in different disciplines of engineering and technology

### **Data and Methodology**

A structured questionnaire was designed and used for collecting data. The data was collected from the librarians of 23 engineering colleges. Copies of questionnaire were personally distributed to the librarians and the response rate was 100%. The data collected from the questionnaires was analyzed and interpreted.

### **Analyses and Interpretation**

#### *A. Working Hours on Working Days*

The distribution of libraries according to working hours on working days is presented in Table I.



TABLE I DISTRIBUTION OF LIBRARIES ACCORDING TO WORKING HOURS ON WORKING DAYS

Working Hours (a.m. – p.m.)	Colleges			Total	
	Private	Non-Minority	Private Minority		Government
9:00 – 6:00	9 (56.25)		3 (75.00)	1 (33.33)	13 (56.52)
9:00 – 7:30	2 (12.50)		0	2 (66.67)	4 (17.39)
8:00 – 8:00	5 (31.25)		1 (25.00)	0	6 (26.09)
Total	16 (100.00)		4 (100.00)	3 (100.00)	23 (100.00)

Note: Figures in parentheses denote percentages.

Table I shows that the majority of libraries (56.52%) work from 9:00 a.m. to 6:00 p.m. i.e., 9:00 hours on all working days, 26.09 per cent of them work from 8:00 a.m. to 8:00 p.m., i.e., 12:00 hours, and the remaining 17.39 per cent work from 9:00 a.m. to 7:30 p.m. i.e., 10:30 hours. It is understood that all the libraries are functioning for 9 to 12 hours a day. Out of the sixteen colleges under private non-minority category, nine libraries (56.25%) work from 9:00 a.m. to 6:00 p.m., five libraries (31.25%) work from 8:00 a.m. to 8:00 p.m. and the remaining two libraries (12.50%) work from 9:00 a.m. to 7:30 p.m.

Out of the four colleges under private minority category, three libraries (75.00%) works from 9:00 a.m. to 6:00 p.m. and the remaining one library (25.00%) work from 8:00 a.m. to 8:00 p.m. Out of the three colleges under government category, two libraries (66.67%) work from 9:00 a.m. to 7:30 p.m. whereas the remaining one library (33.33%) works from 9:00 a.m. to 6:00 p.m. In total, there are about six colleges under private category working from 8:00 a.m. to 8:00 p.m. i.e., twelve hours in a day. It is understood that some colleges have integrated facility of college, library and hostels at one location only. In these campuses the libraries function for twelve hours a day.

### B. Working Hours on Holidays

The distribution of libraries according to working hours on holidays is presented in Table II. Table II shows that the majority of the libraries (78.26%) are not working on holidays. It is also evident from the table that 13.04 per cent of them work from 10:00 a.m. to 2:00 p.m. and the remaining 8.70 per cent work from 9:00 a.m. to 12:30 p.m. Hence it can be concluded that majority of the engineering college libraries are not working on holidays in both the sessions. Out of the sixteen colleges under private non-minority category, thirteen libraries (81.25%) do not work on holidays, two libraries (12.50%) work form 9:00 a.m. to 12:30 p.m. and the remaining one library (6.25%) works from 10:00 a.m. to 2:00 p.m.

TABLE II DISTRIBUTION OF LIBRARIES ACCORDING TO WORKING HOURS ON HOLIDAYS

Working Hours (a.m. – p.m.)	Colleges			Total	
	Private	Non-Minority	Private Minority		Government
9:00 – 12:30	2 (12.50)		0	0	2 (8.70)
10:00 – 2:00	1 (6.25)		1 (25.00)	1 (33.33)	3 (13.04)
Not working	13 (81.25)		3 (75.00)	2 (66.67)	18 (78.26)
Total	16 (100.00)		4 (100.00)	3 (100.00)	23 (100.00)

Note: Figures in parentheses denote percentages.

Out of the four colleges under private minority category, three libraries (75.00%) do not work on holidays and the remaining one library (25.00%) works from 10:00 a.m. to 2:00 p.m. Out of the

three colleges under government category, two libraries (66.67%) do not work on holidays whereas the remaining one library (33.33%) works from 10:00 a.m. to 2:00 p.m.

### C. Charging System

The distribution of libraries according to the charging system followed is presented in Table III.

TABLE III DISTRIBUTION OF LIBRARIES ACCORDING TO THE CHARGING SYSTEM FOLLOWED

Charging System	Colleges			Total
	Private Non-Minority	Private Minority	Government	
Ledger System	2 (12.50)	1 (25.00)	0	3 (13.04)
Browne Charging System	2 (12.50)	2 (50.00)	0	4 (17.39)
Computerized System	12 (75.00)	1 (25.00)	3 (100.00)	16 (69.57)
Total	16 (100.00)	4 (100.00)	3 (100.00)	23 (100.00)

Note: Figures in parentheses denote percentages.

It is evident from Table III that the majority of the libraries (69.57%) are using computerized system for issue and return of documents. It is also evident from the table that 17.39 per cent of them are using Browne charging system and the remaining 13.04 per cent are using ledger system. Out of the sixteen colleges under private non-minority category, twelve libraries (75.00%) are using computerized system for issue and return of documents, two libraries (12.50%) are using ledger system and the remaining two libraries (12.50%) are using Browne charging system. Out of the four colleges under private minority category, two libraries (50.00%) are using Browne charging system for issue and return of documents, one library (25.00%) is using ledger system and the remaining one library (25.00%) is using computerized system. All the three government engineering college libraries (100.00%) are using computerized system for issue and return of documents. It is observed from the table that all the three libraries under government category are using computerized charging system. Automation of circulation section requires financial resources to acquire the required computer systems and peripherals, library automation software and trained man power. Hence, it is understood that government engineering institutions have sufficient financial resources and human resources for automation of their in-house operations.

### D. Issue and Return of Documents

The distribution of libraries according to days on which 'issues and returns' are performed is presented in Table IV.

TABLE IV DISTRIBUTION OF LIBRARIES ACCORDING TO ISSUE AND RETURN OF DOCUMENTS

Day(s)	Colleges			Total
	Private Non-Minority	Private Minority	Government	
All the Days in a Week	16 (100.00)	3 (75.00)	3 (100.00)	22 (95.65)
Particular Day (s) in a Week	0	1 (25.00)	0	1 (4.35)
Total	16 (100.00)	4 (100.00)	3 (100.00)	23 (100.00)

Note: Figures in parentheses denote percentages.

It is evident from Table IV that in most of the libraries (95.65%) the documents are issued and returned on all the working days in a week and the remaining 4.35 per cent replied that the documents are issued and returned only on particular day(s) in a week. In all the sixteen private

non-minority colleges (100.00%) and also in all the three government colleges (100.00%), the documents are issued and returned on all the working days in a week. Out of the four colleges under private minority category, in three libraries (75.00%) the documents are issued and returned on all the working days in a week, whereas in one college (25.00%) the documents are issued and returned on particular day(s) in a week.

*E. Collection of Overdue Charges*

The distribution of libraries according to collection of overdue charges from their users is presented in Table V.

TABLE V COLLECTION OF OVERDUE CHARGES

Response	Colleges			Total
	Private Non-Minority	Private Minority	Government	
Yes	14 (87.50)	4 (100.00)	3 (100.00)	21 (91.30)
No	2 (12.50)	0	0	02 (8.70)
Total	16 (100.00)	4 (100.00)	3 (100.00)	23 (100.00)

Note: Figures in parentheses denote percentages.

The data presented in the Table V shows that most of the libraries (91.30%) are collecting overdue charges from the users for not returning documents within the due date and the remaining 8.70 per cent of them replied negatively in this regard. Out of the sixteen colleges under private non-minority category, fourteen libraries (87.50%) are collecting overdue charges and the remaining two libraries (12.50%) are not collecting overdue charges from their users. All the four college libraries (100.00%) under private minority category and all the three college libraries (100.00%) under government category are not collecting overdue charges from their users.

*F. Access System Followed*

The library can follow either open access system or closed access system. In open access system, the user has the freedom to go to the shelves directly and browse the books of his/her choice in the stack area of the library. In the closed access system, the user approaches the library staff for books of his/her choice. The distribution of libraries according to the access system followed is presented in Table VI.

TABLE VI DISTRIBUTION OF LIBRARIES ACCORDING TO THE ACCESS SYSTEM

Response	Colleges			Total
	Private Non-Minority	Private Minority	Government	
Open access	16 (100.00)	4 (100.00)	3 (100.00)	23 (100.00)
Closed access	0	0	0	0
Mixed	0	0	0	0
Total	16 (100.00)	4 (100.00)	3 (100.00)	23 (100.00)

Note: Figures in parentheses denote percentages.

The data presented in Table VI shows that all the twenty-three libraries (100.00%) under three categories viz., private non-minority, private minority and government, are following open access system in all the wings of their libraries for the benefit of users.

### G. Library Sections

In order to provide effective library services to their stakeholders, the library is organized into different sections. The distribution of libraries according to existence of different sections is presented in Table VII.

TABLE VII DISTRIBUTION OF LIBRARIES ACCORDING TO LIBRARY SECTIONS

Section	Colleges			Total
	Private Non-Minority (N=16)	Private Minority (N=4)	Government (N=3)	
Acquisitions Section	16 (100.00)	4 (100.00)	3 (100.00)	23 (100.00)
Technical Processing Section	16 (100.00)	4 (100.00)	3 (100.00)	23 (100.00)
Periodicals Section	16 (100.00)	4 (100.00)	3 (100.00)	23 (100.00)
Textbook Section	16 (100.00)	4 (100.00)	3 (100.00)	23 (100.00)
Reference Section	16 (100.00)	4 (100.00)	3 (100.00)	23 (100.00)
SC/ST Book Bank Section	16 (100.00)	0 (0.0)	3 (100.00)	19 (82.61)
Circulation Section	16 (100.00)	4 (100.00)	3 (100.00)	23 (100.00)
Reprographic Section	16 (100.00)	4 (100.00)	3 (100.00)	23 (100.00)

Note: i. Librarians are permitted to tick more than one answer, ii. Figures in parentheses denote percentages.

It is evident from Table VII that all twenty-three libraries (100.00%) have acquisitions section, technical processing section, periodicals section, text book section, reference section, circulation section and reprographic section. It is also evident from the table that most of the libraries have SC/ST Book Bank section (82.61%). The SC/ST Book Bank section is available in all the sixteen libraries (100.00%) under private non-minority category and also in all the three libraries (100.00%) under government category. The SC/ST Book Bank section is not available in all the four libraries (100.00%) under private minority category.

### Major Findings

1. Most of the libraries (95.65%) the documents are issued and returned on all the working days in a week.
2. Majority of the libraries (69.57%) are using computerized system for issue and return of documents.
3. Most of the libraries (91.30%) are collecting overdue charges from the users for not returning documents within the due date.
4. All the twenty-three libraries (100.00%) under three categories viz., private non-minority, private minority and government, are followed open access system.
5. All twenty-three libraries (100.00%) have acquisitions section, technical processing section, periodicals section, text book section, reference section, circulation section and reprographic section.

### **Suggestions and Conclusion**

The circulation desk, as the public relation section of the library, plays a frontline and essential role in promoting its image. Through this section, library procedures are made accessible to the general public. It therefore follows that the sensitive nature of this section requires competent man power to operate it. The need to equip it adequately need not be exaggerated. Still, the available facilities at the circulation desk of the college library have to a very large extent enable the staff attends to the clientele adequately. Overdue charges are considered by some librarians as a source of income but generally the purpose of an overdue charges system is to ensure the prompt return of books by the end of loan period. The non-return of books when due interferes with the right of other borrowers and results in a poorer level of service.

### **References**

- [1] Chinna Balu, C. (2011). *A survey of engineering college libraries and their users in Sri Venkateswara University area*. Sri Venkateswara University, Andhra Pradesh, Tirupati. <https://shodhganga.inflibnet.ac.in/handle/10603/195961>.
- [2] Dinkins, D. (2003). Circulation as assessment: Collection development policies evaluated in terms of circulation at a small academic library. *College & Research Libraries*, 64(1), 46-53.
- [3] G.Veena and Prabhakara Narasimha Kotari (2016) User Satisfaction with Library Resources, Services and Facilities: A Study in SDM College Library, Ujire. *Indian Journal of Information Sources and Services*, 6 (1), 1-4.
- [4] Knievel, J. E., Wicht, H., & Connaway, L. S. (2006). Use of circulation statistics and interlibrary loan data in collection management. *College & Research Libraries*, 67(1), 35-49.
- [5] Sharma S C (2001). Status of engineering college libraries in Haryana: A survey. *ILA Bulletin*, 37; 101-106.
- [6] Suryanarayana (N) and Hugar (N C). Planning an automated circulation system for an academic library. *Lucknow Librarian*. 20, 2; 1988; 53-67.
- [7] Tayewo Olayinka (2013). Circulation Activities in Tertiary Institutions in Nigeria: A Discourse on Circulation Transactions of Yaba College of Technology Library. *Information and Knowledge Management*, 3 (4), 24-32.

# Anuvadini AI Portal: AICTE's Revolutionary Approach to Enhancing Language Accessibility and Communication in Libraries and Academic Engagements

M. Prakash<sup>1</sup>, J. Arumugam<sup>2</sup> and M. Sathish Kumar<sup>3</sup>

<sup>1&2</sup>Librarian, <sup>3</sup>Research Scholar

<sup>1&2</sup>PSG College of Technology, Coimbatore, Tamil Nadu, India

<sup>3</sup>Department of Library, PSGR Krishnammal College for Women, Coimbatore, Tamil Nadu, India

E-mail: mprakashlis@gmail.com, jacs1986tv1@gmail.com, sathishbhc123@gmail.com

## Abstract

*This article explores the revolutionary approach of AICTE's Anuvadini AI Portal in transforming language accessibility and communication within libraries and academic engagements. With India's diverse linguistic landscape posing both a cultural emblem and an educational challenge, Anuvadini emerges as a pivotal solution, offering translation tools for 22 Indian and foreign languages. The tools span various categories such as voice, video, education, PDF, and image, aiming to break language barriers and foster communication. The objectives include understanding the Anuvadini AI Portal's fundamental options, evaluating its diverse features, and showcasing merits and demerits within the context of various tools. The tools encompass multifunctional capabilities, language diversity, innovative audio enhancement, educational support, and efficient PDF handling. However, limitations include file size restrictions, internet dependency, quality assurance concerns, a learning curve for certain tools, and limited language coverage nuances. The article concludes by emphasizing the transformative potential of Anuvadini while acknowledging the need for continuous updates, user guidance, and considerations for nuanced language contexts to ensure its effectiveness and inclusivity.*

**Keywords:** Language Accessibility, Library Operations, Translation Tools, Voice Tools, Video Tools, Education Tools, PDF Tools, Image Tools, Communication, Innovation, AICTE, AI Tools

## Introduction

In the intricate tapestry of India's linguistic diversity, language stands as both a cultural emblem and a formidable barrier. With 80% of the population identifying as native language speakers, the richness of regional dialects defines the nation's identity but poses a significant challenge in delivering standardized education to students speaking diverse languages. The ANUVADINI Voice & Document AI Translation Tools, featuring support for 22 Indian and foreign languages, emerges as an indispensable solution to bridge this linguistic gap within higher education. By dismantling language barriers, ANUVADINI aims to unify India and the global community, echoing the spirit of "Ek Bharat Shrestha Bharat" and "One Earth, One Family, One Future!" Originally conceptualized to provide equitable access to quality education, ANUVADINI promises enhanced communication and information flow across various sectors. This article explores the revolutionary potential of the Anuvadini AI Portal developed by AICTE, focusing on its diverse tools catering to language accessibility, library operations, and academic engagements.

## Objectives

1. To Understand the Fundamental Options and Various Tools within the Anuvadini AI Portal
2. To Evaluate the Diverse Features and Functionalities of Anuvadini AI Portal
3. To Showcase Merits and Demerits within the Context of Various Tools

## **Review of Literature**

Chan, C. K. Y. (2023) investigated the development of an AI education policy for higher education, specifically focusing on the perceptions and implications of text generative AI technologies. Collecting data from 457 students and 180 teachers and staff in Hong Kong universities through quantitative and qualitative research methods, the study proposes an AI Ecological Education Policy Framework. This framework, organized into Pedagogical, Governance, and Operational dimensions, offers a comprehensive approach to address the multifaceted implications of AI integration in university teaching and learning. The Pedagogical dimension emphasizes enhancing teaching and learning outcomes, the Governance dimension addresses privacy, security, and accountability concerns, while the Operational dimension tackles infrastructure and training matters. The proposed framework provides stakeholders with a nuanced understanding of their roles and responsibilities in the context of AI integration, fostering responsible and ethical usage. However, the study acknowledges limitations, such as a relatively small sample size and a focus solely on text-based generative AI, urging the need for further research to comprehend both advantages and risks associated with AI in academic settings. The proposed AI Ecological Education Policy Framework serves as a valuable foundation for educational institutions to navigate responsible AI implementation while maximizing its benefits.

Cox and Tzoc (2023) explore the transformative impact of ChatGPT on academic libraries, providing a comprehensive overview of its potential implications for higher education. Highlighting ChatGPT's rapid popularity, reaching one million users within a week of its November 2022 launch, the authors delve into its capabilities as a large language model (LLM) tool employing deep learning techniques. The study discusses how ChatGPT can generate a wide range of content, from essays to medical diagnoses, based on its training on diverse textual sources. The authors scrutinize ChatGPT's role in academic settings, addressing its use in areas such as discovery and search, research assistance, reference services, teaching, and the creation of educational materials. Furthermore, the study contemplates ethical concerns related to plagiarism, copyright, and biases in AI-generated content. While acknowledging the revolutionary potential of AI tools, the authors emphasize the importance of integrating these technologies thoughtfully into library services, considering biases, quality improvement, and their role in supporting human interactions in libraries. The study prompts librarians and information professionals to engage in ongoing conversations about leveraging AI tools while maintaining the distinct value of human expertise in library services.

Fitria, T. N. (2021) studied the transformative impact of Artificial Intelligence (AI) in education, particularly in the teaching and learning process. The study delves into various applications of AI, such as Virtual Mentor, Voice Assistant, Smart Content, Presentation Translator, Global Courses, Automatic Assessment, Personalized Learning, Educational Games, and Intelligent Tutoring System (ITS). The research highlights AI's potential to revolutionize the education landscape, automating tasks like correcting assignments and conducting assessments, thereby allowing teachers to focus on non-systemic aspects of education. Fitria underscores that AI, born from the creative minds of human natural intelligence, is a valuable tool but cannot replace the innate qualities of teachers. The article emphasizes that education is a multifaceted process involving not only knowledge acquisition but also the development of social skills and character. While AI contributes to personalize learning experiences, it may hinder human interaction and the cultivation of essential social skills. Author acknowledges the benefits AI brings to students and educators, such as flexible learning schedules, personalized learning experiences, and automatic assessment tools. However, the article cautions about potential drawbacks, including the high cost, dependence on infrastructure, cybersecurity concerns, and the risk of AI-induced plagiarism. Despite these challenges, this research anticipates a positive impact of AI in education,

particularly in facilitating learning during pandemics and adapting to evolving educational demands. In the conclusion, this research emphasizes the irreplaceable role of educators in inspiring, motivating, and character development, areas where AI falls short due to its lack of emotions and feelings. The author advocates for educators to embrace technological advancements while preserving the essential human touch in education. The research provides a comprehensive overview of AI in education, highlighting its promises and challenges and emphasizing the indispensable role of teachers in shaping students' holistic development.

### Translation Tools

S.No.	Name of the Tool	Description
1	Online Document Translation Tool	It helps to translate files of up to 20 pages via language selection as source and destination. For larger translations, email cconeat[at]aicte-india[dot]org and cc startupfellow5[at]aicte-india[dot]org. Upload .pdf or .docx files, compare, and contribute text using Voice for seamless collaboration.
2	Ananta (AI engine with boundless deep search capabilities across MS Word, PDFs, PPTX, textual content, audio, and video formats.)	Create a new ANANTA account or log in. Choose the source document's language, then upload your file (.doc, .txt, .pptx, .pdf, .mp3, .wav, .mp4) and submit. Leverage Custom Summary, Document Generative QnA, or Ask a Question features for deeper document comprehension. Save the session or append additional files for enhanced insights.
3	Voice Based Multi lingual platform (A web-based tool for generating forms in various Indian languages.)	Either upload a .wav file or record directly on the page. Preview the uploaded or recorded file, adjust parameters as needed, and then submit. Compare the result displayed on the screen with the original file, and finally, click download to complete the process.
4	Virtual Keyboard (An online tool for entering text in multiple Indian languages.)	It is internet-based utility enabling text input across various Indian languages. Users can choose from multiple languages and access features like Word Count, Printing, Saving as Doc or Pdf files, and Resetting.
5	Government of India Schemes Voice-enabled search for Schemes & Initiatives (Chat GPT).	Easily navigate Indian Government Schemes using voice-activated search through Chat GPT technology. Upon language selection, the portal instantly offers scheme information and accommodates queries. Additionally, multiple language options are available for selection.
6	Dictation Tool (This tool simplifies the process of note-taking.)	This tool streamlines note-taking for transcribers and users, allowing concurrent text editing and viewing of sessions. It offers dictation ordering, a real-time text editor, and session storage capabilities.
7	Legal Glossary (Entry to an extensive and credible repository)	Provides an extensive array of legal terms, comprising over 35,000 precisely translated words and phrases in various Indian regional languages. Users have the ability to: Explore Indian laws in multiple regional languages. Initiate searches by typing or recording in their preferred language. Share translations, validated by legal professionals to guarantee precision and authenticity.
8	BhashaDaan (Explore and curate an assortment of Indian language words and sentences.)	Explore and contribute to the compilation of Indian language words and sentences through Anuvadini-c, a community-powered repository. Discover the finest Indian language prompts categorized by sectors, professions, or specific use cases.



**Voice Tools**

S.No.	Name of the Tool	Description
1	Speech to Speech (Translation Service)	Choose your language from the provided dropdown menu for speaking. Begin recording by clicking 'Start Recording.' Use the 'Pause/Resume Recording' button to take breaks and resume recording. The recorded text will be displayed on the screen in your native language. Choose the voice gender from the gender dropdown menu to proceed. Select the desired language for translation from the language dropdown menu. Initiate the translation process by clicking the 'Convert to Speech' button. Play the converted audio using the play button. Adjust the pace and pitch of the AI-generated audio. Download the audio as a (.wav) file by clicking the 'Download As Audio' button.
2	3D Audio (Improve the stereo sound by incorporating a three-dimensional effect.)	Facilitate captivating spatial audio experiences by generating the perception of a three-dimensional environment around the listener through the strategic placement or movement of sounds in different directions. Either upload a file in the supported .wav format or record directly from the page. Preview the uploaded or recorded file, adjust parameters as needed, and submit. Compare the result with the provided file displayed on the screen. Conclude the process by clicking on the download option.
3	Auto Panner (Create a dynamic shift in the audio, moving it back and forth between the left and right channels.)	Innovatively manage audio files to autonomously regulate the panning of audio within a stereo image, either moving it from left to right or in a circular pattern, thereby crafting distinctive listening encounters. Choose to upload a file in the supported .wav format or record directly from the page. Upon upload or recording, preview the file, modify parameters as needed, and submit. Evaluate the result against the provided file displayed on the screen. Conclude the process by clicking on the download option.
4	Bass Booster (Amplify the bass of a song, increasing its bass intensity.)	Improve the lower frequency range of any audio file to generate a more robust and lively bass response, resulting in an invigorated listening experience. Choose to upload a file in the supported .wav format or record directly from the page. Once uploaded or recorded, preview the file, adjust parameters as needed, and click submit. Evaluate the outcome by comparing it with the displayed reference file on the screen. Finalize the process by clicking on the download option.
5	Equalizer (Modify the frequencies of your audio.)	A crucial tool enabling the manipulation and fine-tuning of the frequency spectrum of any audio, allowing the creation of a tailored and distinctive listening experience.
6	Noise Reducer (Minimize ambient noise in recordings.)	Facilitates the effortless conversion of noisy live recordings or interviews into high-quality, uncompressed, noise-free audio files by eliminating ambient environmental noise. Opt to upload a file in the supported .wav format or record directly from the page. Following upload or recording, preview the file, adjust parameters as needed, and click submit. Evaluate the result by comparing it with the provided file on the screen. Conclude the process by clicking on the download option.
7	Pitch Shifter (Change the pitch of your audio)	Enables the adjustment of the pitch for any audio, creating a higher or lower pitched version of the audio file. Note that altering the pitch does not maintain the original audio pace, leading to longer audio for decreased pitch and vice versa.

8	Reverb (Increase the room size of your audio)	Immerse yourself in diverse spaces, from intimate chambers to vast halls, with this effect that adds room-specific reverb to any audio file, enhancing your listening experience. It keeps the core concept of adding room reverb for different sizes while slightly restructuring the sentence for flow.
9	Reverb (Reverse an audio file and make it play backwards)	Flip any audio on its head, from music to sound effects, with this tool that instantly rewinds time for your sound files.
10	Reverse Audio (Reverse an audio file and make it play backwards)	Flip audio on its back, unlocking backward journeys for any sound. Experiment with music, effects, and more to build a sonic playground.
11	Stereo Panner (Pan the audio to left or right)	Unleash the freedom of panning, taking audio on a dynamic journey across the stereo field, left to right or in endless loops, for mind-bending listening adventures.
12	Tempo Changer (Make an audio file play faster or slower)	Warp the speed of any audio without bending its tone, crafting hyper-customized versions from raw files.
13	Vocal Remover (Remove the vocals from a song leaving only the instrumental)	Offers the capability to convert audio files containing vocal singing or speech into exclusively instrumental audio files by isolating and removing frequencies associated with the human voice range.
14	Volume Changer (Make your audio louder or quieter)	Enables the manipulation of the volume for any audio file, a crucial feature for increasing the volume of raw audio files that are too soft or decreasing it, as needed.
15	Speech Messenger (Communication with your native language -text, audio or video supported)	Communicate in your native tongue like never before, using text, voice, or video in this intuitive messaging platform.

### Education Tools

S.No.	Name of the Tool	Description
1	Core Engineering Generative AI (A student-friendly solution designed to spread information on fundamental engineering subjects in various Indian languages.)	Introducing Core Engineering Generative AI, an approachable solution dedicated to sharing information on key engineering disciplines in various Indian languages. The covered streams include Civil Engineering, Mechanical Engineering, Electrical Engineering, and Electronics and Communication Engineering.
2	Handwritten AI	Upload handwritten text in the form of an image. This tool promptly recognizes the text upon upload.

### PDF to Anything Tools

S.No.	Name of the Tool	Description
1	PDF Tools	Capabilities encompass a diverse range of PDF-related tasks. These include merging and splitting PDFs, compressing files, adding page numbers, converting PDFs to images and vice versa, securing and unlocking PDFs, transforming text and DOCX files to PDF format, converting presentations and Excel files to PDFs, extracting text and images from PDFs, and optimizing files for web viewing. Additionally, Portal offer the conversion of JPG images into PDFs, the creation of new PDFs, and the incorporation of watermarks. Furthermore, their services extend to the extraction of images from PDFs and the facilitation of creating PDF-based job applications.

### Video Tools

S.No.	Name of the Tool	Description
1	AI Video Analyser	Examine real-time facial expressions within any video, extracting valuable insights into emotions effortlessly with just a few clicks. Gain a comprehensive understanding of the emotions conveyed through every smile, frown, and various other facial expressions.
2	AI Youtube-Video Analyser	Explore the capabilities of Anuvadini, an advanced tool harnessing AI to produce concise and informative summaries for your preferred YouTube videos. This innovative tool seamlessly summarizes and translates content across languages. The YouTube Video Analyzer feature of Anuvadini is easily navigated in a few simple steps: begin by selecting the YouTube video containing the desired transcript for summarization or analysis, and copy its URL. Ensure the video has captions or a transcript, often provided by the creator or accessible through the CC (Closed Captions) button. Utilize the summarize/analyze feature on Anuvadini by visiting the platform, inputting the YouTube video URL, and clicking "Analyze it" to receive a summary of the content. The AI Custom summary extension ensures a quick grasp of the video's essence, even for lengthy content. Customize the summary in your native language by selecting from the dropdown language options, enabling a personalized Q&A experience. Finally, save and download your generated summary video for immediate use and sharing.

S.No.	Name of the Tool	Description
1	Image 23 (Translate Photos into 30+ languages in Seconds, whether they are poster, brochures, screenshots, advertisements.)	Effortlessly translate images into over 30 languages within seconds, covering a variety of visual content such as posters, brochures, screenshots, advertisements, and product images. Supported file formats include JPEG, JPG, and PNG, with a maximum file size of 2MB. Simply click on the upload icon, and upon receiving the successful upload message, proceed to initiate OCR-based Imagine InPasting. Once the process is completed, the translated image will be presented and can be downloaded in both JPG and PNG formats.

### Merits

- Multifunctional Capabilities:** These translation tools offer a diverse range of features, allowing users to perform various tasks such as merging, splitting, compressing, and converting files between different formats, catering to a wide array of needs.
- Language Diversity:** The tools support multiple Indian languages, providing users with the flexibility to work in their preferred regional language. This enhances accessibility and inclusivity, especially in a linguistically diverse country like India.
- Innovative Audio Enhancement:** The audio tools showcase innovative features, such as 3D audio effects, auto panning, bass boosting, and equalization, offering users the ability to customize their listening experiences and improve audio quality.
- Educational Support:** The educational tools, like Core Engineering Generative AI, cater to students by disseminating information in various Indian languages, promoting accessibility and understanding in fundamental engineering subjects.
- Efficient PDF Handling:** The PDF-related tools streamline tasks such as merging, splitting, compressing, and converting, providing a comprehensive solution for managing PDF files. The inclusion of watermarking and image extraction adds versatility to these tools.

### Demerits

- Limited File Size:**
  - Some tools impose restrictions on file size, hindering the handling of larger documents or files.

b. This limitation may impact users dealing with extensive data or larger projects, necessitating alternative solutions.

2. *Dependency on Internet:*

a. Certain tools, notably the virtual keyboard and online document translation tool, depend on internet connectivity.

b. This reliance may pose challenges in situations with limited or no internet access, affecting the seamless use of these tools.

3. *Quality Assurance:*

a. The accuracy and reliability of translation tools, particularly those involving AI like Anuvadini, may vary.

b. Users should exercise caution and conduct thorough checks, as errors in translation could lead to misunderstandings or misinterpretations.

4. *Learning Curve:*

a. Tools like the AI video analyzer and Anuvadini may have a learning curve, especially for users unfamiliar with advanced features.

b. Adequate user guidance and tutorials are essential for maximizing the benefits of these tools, ensuring efficient utilization.

5. *Limited Language Coverage:*

a. While tools offer support for multiple Indian languages, limitations exist in terms of coverage or nuances of regional dialects.

b. Continuous updates and expansions in language support are needed to enhance the tools' effectiveness, ensuring inclusivity across diverse linguistic contexts.

## Conclusion

The AICTE's Anuvadini AI Portal emerges as a groundbreaking solution to address the intricate challenges posed by India's diverse linguistic landscape in the realms of education, libraries, and academic engagements. The revolutionary approach of Anuvadini, offering translation tools for 22 Indian and foreign languages across various categories, holds transformative potential in breaking down language barriers and fostering effective communication. The multifunctional capabilities, language diversity, innovative audio enhancement, educational support, and efficient PDF handling presented by Anuvadini showcase its comprehensive approach to language accessibility. However, the demerits, including file size restrictions, internet dependency, quality assurance concerns, a learning curve for certain tools, and limited language coverage nuances, underscore the importance of continuous updates, user guidance, and considerations for nuanced language contexts. Despite these challenges, Anuvadini stands as a testament to AICTE's commitment to advancing inclusivity and communication, and its potential to reshape the landscape of language accessibility in India and beyond. As we move forward, a concerted effort towards refining and expanding the capabilities of Anuvadini will be crucial in realizing its full potential and ensuring a more inclusive and connected future.

## References

- [1] Adeshola, I., & Adepoju, A. P. (2023). The opportunities and challenges of ChatGPT in education. *Interactive Learning Environments*, 1-14.
- [2] Chan, C. K. Y. (2023). A comprehensive AI policy education framework for university teaching and learning. *International journal of educational technology in higher education*, 20(1), 38.
- [3] Cox, C., & Tzoc, E. (2023). ChatGPT: Implications for academic libraries. *College & Research Libraries News*, 84(3), 99.
- [4] Crompton, H., & Burke, D. (2023). Artificial intelligence in higher education: the state of the field. *International Journal of Educational Technology in Higher Education*, 20(1), 1-22.

- [5] Fitria, T. N. (2021, December). Artificial Intelligence (AI) In Education: Using AI Tools for Teaching and Learning Process. In *Prosiding Seminar Nasional & Call for Paper STIE AAS* (Vol. 4, No. 1, pp. 134-147).
- [6] Gillani, N., Eynon, R., Chiabaut, C., &Finkel, K. (2023). Unpacking the “Black Box” of AI in Education. *Educational Technology & Society*, 26(1), 99-111.
- [7] Michel-Villarreal, R., Vilalta-Perdomo, E., Salinas-Navarro, D. E., Thierry-Aguilera, R., & Gerardou, F. S. (2023). Challenges and opportunities of generative AI for higher education as explained by ChatGPT. *Education Sciences*, 13(9), 856.

# The Role of Forensic Accounting and Management Control Systems as Tools in Combating Cyber Fraud in FinTech Services

M. Leelavathi<sup>1</sup>, R. Gowtham<sup>2</sup> and Dr. A.N. Radhika<sup>3</sup>

<sup>1</sup>Research Scholar, <sup>2</sup>Asst. Professor, <sup>3</sup>Sr. Asst. Professor

<sup>1</sup>Periyar University, Salem, Tamil Nadu, India

<sup>2&3</sup>St. Pauls College, Nagasandra, Bangalore, Karnataka, India

## Abstract

*Forensic accounting is the application of investigative and analytical skills to resolve financial issues in a manner that meets standards required by courts of law. Forensic accountants apply special skills in accounting, auditing, finance, quantitative methods, certain areas of the law, research, and investigative skills to collect, analysed evaluate evidential matter and interpret and communicate findings. (Hopwood, Leiner and Young, 2008). The necessity of protecting financial systems from the ever-increasing risk posed by cyber breaches has reached a level of relevance that is unique in the rapidly evolving landscape of Fin-tech Services. This landscape is characterised by the convergence of technical breakthroughs and innovative financial practices. This research goes on a thorough exploration, delving into the complexities of the symbiotic relationship between Forensic Accounting and Management Control Systems (MCS), which stand as strong guardians in the intensifying struggle against cyber fraud. The purpose of this research is to provide a better understanding of how forensic accounting and MCS may work together to combat cyber fraud.*

**Keywords:** Forensic accounting, analytical skills, Control System, cyber fraud.

## Introduction

Forensic accounting, which is gifted with its investigative prowess and financial understanding, performs a crucial role as a front-line defence mechanism. This is because forensic accounting has both of these attributes. These collaborative systems constitute a dynamic alliance with a unique purpose: to safeguard the integrity and security of financial transactions within the Fin-tech industry. This alliance is formed through the seamless integration of these systems with the sturdy framework of MCS. This integration is extensively dissected in the paper, which reveals the intricate ways in which forensic accounting and MCS work together to strengthen financial systems in the face of an increasingly complex cyber threat scenario. An investigation on the effect that MCS has on cyber fraud will make up a significant portion of the project. The purpose of this study is to derive significant insights that can inform the improvement of tactics targeted at enhancing cyber resilience by critically analysing the effectiveness of these control systems in detecting and preventing fraudulent activity. It investigates the preventative mechanisms that allow MCS to function as a formidable deterrent, constructing a shield against unauthorised access, fraudulent transactions, and several other types of cyber dangers.

### A. Overview of Research

The purpose of this research is to broaden its reach by attempting to decipher the complex relationships that exist between Forensic Accounting, MCS, and cyber fraud within the particular setting of Fintech Services. In doing so, it aims to make clear the complex web of interrelationships that exist between these many components by taking into account the synergies that exist between them and the possibility for technological developments that can help strengthen the digital financial landscape. The purpose of the study is to expand people's knowledge, and one of its goals is to make a significant contribution to the existing body of information regarding forensic accounting and MCS as it relates to online fraud. The purpose of

this project is to produce insights that will not only raise scholarly debate but will also inform and shape professional practices, thereby cultivating a financial ecosystem that is more robust and adaptable.



Fig.1 Role of Fintech in the banking and Financial Service Industry in India

The study does not restrict itself to the use of conventional research methods; rather, it boldly travels into the domains of newly developing technologies such as artificial intelligence, block-chain, cloud computing, and big data. In light of the fact that cyber dangers are always evolving, the purpose of this investigation is to come up with novel approaches to cyber-security and to propose these approaches. This perspective on the future places the study at the forefront of the effort to address the complex problems that arise from the junction of financial services, technology and security.

In a nutshell, this research represents a holistic and forward-looking endeavour, with the goal of bridging the gap between traditional accounting practices and the cutting-edge technologies that are redefining the financial scene. In other words, it aims to bridge the gap between traditional accounting practices and the technologies that are reshaping the financial landscape. The purpose of this study is not only to understand the issues that are now being faced, but also to pave the path for a more secure, adaptable, and resilient future for Fin-tech Services. This will be accomplished by unravelling the intricate tapestry that is forensic accounting, management control systems, and developing technology.

### **Review of Literature**

The literature review serves as a critical component in academic research, offering a comprehensive examination and synthesis of existing scholarly works relevant to the research topic. This section provides a foundation for the study by presenting a thorough understanding of the current state of knowledge, identifying gaps, and contextualizing the research within the broader academic discourse. In the following introduction to the review of literature, the emphasis is placed on its significance in shaping the research narrative.

According to Dubinina *et al.*, (2018), forensic accounting represents a multidisciplinary field that integrates accounting, auditing, criminology, and law. It functions to conduct impartial investigations on behalf of stakeholders and business owners, aiming to uncover fraud and provide support in legal proceedings. This method combines conventional accounting practices with legal principles, ensuring a comprehensive approach to addressing financial misconduct. The primary objective is to locate and monitor potential fraud cases, thereby actively contributing to the fight against financial crime (Hibshi *et al.*, 2011; Grubor *et al.*, 2013).

Howard & Sheetz (2006) describe forensic accounting as the process of understanding, summarizing, and presenting complex financial issues concisely, clearly, and accurately. This approach is crucial for identifying fraud, and forensic accountants follow a meticulous investigation of suspected fraud instances. The emphasis lies not only on adhering to the rules of evidence but also considering the commercial realities and numerical aspects of suspected criminal situations. In the context of this study, forensic accounting is examined in relation to network security, fraud investigation, prevention, and detection with the specific aim of mitigating cyber fraud. Recognized as a specialized field of accounting, forensic accounting contributes to dispute settlement processes and provides crucial evidence in corruption trials (Okoye & Gbegi, 2013).

Professionals engaged in forensic computer investigation employ systematic techniques, including evaluating circumstances, gathering information, conducting preliminary questionnaires, and determining the presence of persistently unwanted activities. This thorough approach underscores the critical role of forensic accounting in identifying financial irregularities, supporting legal actions, and facilitating dispute resolution.

S. Nandini and Raju, Ajay's (2021) study explores the impact of forensic auditing on fraud detection and prevention within business entities and financial performance. The theoretical examination delves into how forensic auditors handle fraud, their distinctions from statutory auditors, unique features, and the consequent effects on corporate governance. The study utilizes various methods, including tabulation, regression, graphing, and charts, for data analysis. With a sample size of 125 participants, the researchers collected data through structured questionnaires directed towards auditors, accountants, managers, professional accountants, and individuals with accounting experience. Regression analysis using the statistical program SPSS was employed, revealing a significant adverse effect of forensic audits on the frequency of fraud cases and employee involvement in fraudulent activities. This underscores the substantial role of forensic audits in reducing fraudulent activities in business environments, offering valuable insights for both scholarly and practical purposes.

Okafor's (2012) study focuses on the significance of domestic macroeconomic variables for foreign direct investment (FDI) inflow in Nigeria. The study, using the ordinary least square method, finds that foreign direct investment in Nigeria is majorly determined by real gross domestic product, interest rate, and real exchange rate. The study suggests that improving the macroeconomic environment is crucial for attracting and benefiting from foreign direct investment.

Asiedu (2006) explores the influence of natural resources and market size on FDI flows to Sub-Saharan Africa. The study, based on data for 22 SSA countries from 1984 to 2000, suggests that countries endowed with natural resources or large markets attract more FDI. However, small countries lacking natural resources can also attract FDI by improving institutions, policy environments, and ensuring stability.

Piteli's (2009) study investigates the determinant factors of foreign direct investment (FDI) by multinational corporations (MNCs) in developed economies. Using an estimated equation derived from economic theory, the study compares demand and supply-side determinants of FDI between EU and non-EU countries. The findings indicate the value of total factor productivity (TFP) as the determining factor of FDI in developed countries.



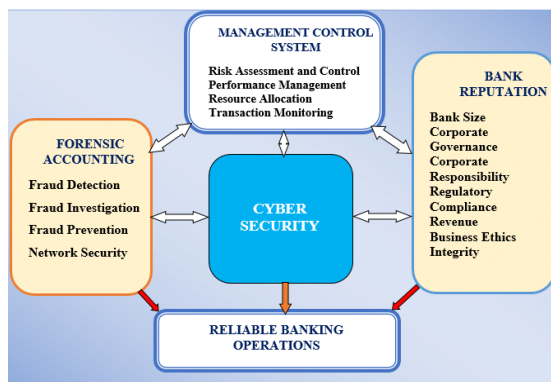

Fig.2 Theoretical Framework

- A. *Product Life Cycle Theory*: Vernon's (1966) theory explains the diffusion of technological innovations and the four phases of production: innovation, growth, maturity, and decline. Foreign direct investment is seen as a critical stage in the product development life cycle.
- B. *Internalization Theory*: Casson and Buckley's (1976) theory emphasizes the growth and motivations of multinational corporations. It posits that FDI occurs when the exploitation of firm-specific advantage outweighs the relative cost of investing abroad.
- C. *Eclectic Paradigm Theory*: Dunning's (1993) eclectic paradigm combines Ownership, Location, and Internalization (OLI) conditions to describe how factors contribute to changes in foreign direct investments. The theory highlights the importance of ownership-related advantages, locational benefits, and internalization for multinational corporations.

These theories collectively contribute to a comprehensive understanding of the complexities surrounding forensic accounting, forensic auditing, and foreign direct investment, providing valuable insights for academic research and practical applications in various economic contexts.

**Research Methods**

- 1. *Methodology of the Study Data Source*: The research is based on primary data Collection Method (The datas were collected through a questionnaire survey method. and secondary data from journals, reports and websites. Bird Eye View Technique has been followed).
- 2. *Sampling Design*: It is decided to utilise judgemental sampling. Participants are chosen using this method based on an experienced individual's assessment that they will fit the study's requirements. This is utilised when just a small group of persons or a certain type of people has the information that is being sought.

A. *Sample for the Study*: The sample size selected is 800.

B. *Implications of the Study*: In completing their assessments, exams, and enquiries, forensic accountants seek simply the truth, merely delivering the "actual" conclusion of their findings in a "unbiased" and objective manner. The services of forensic accountants are in the following areas:

- a) Employee fraud detection
- b) Criminal investigation
- c) Outgoing partner settlement

- d) Arbitration service
- e) Settlement of insurance claims
- f) Dispute settlement
- g) Cases relating to professional negligence.

In the accounting profession, forensic accounting is a rapidly growing field. The current litigious corporate environment, as well as the rising amount of fraudulent business activities, are factors contributing to this development. This comprehensive research methodology integrates both quantitative and qualitative approaches, allowing for a nuanced exploration of the complex relationships and challenges in the realm of financial security and cybersecurity within the finch industry.

### **Objectives of the study**

1. To understand the Forensic Accounting and its integration with Management Control System.
2. To explore the impact of MCS in cyber fraud
3. To understand the relationship between Forensic Accounting, Management Control System, and the cyber fraud in Fin-tech Services
4. To gain knowledge in the field of Forensic Accounting and MCS with reference to cyber fraud in Fin-tech Services
5. To bring an exploratory idea on Forensic Accounting and Fin-tech Services - AI, Block-chain, Cloud and Big Data.

### **Limitations of the study**

1. This study highly concentrating on Fin -Tech services.
2. This study is time bounded of past 3 years.

### **Research Questions**

1. How does the integration of Forensic Accounting and Management Control Systems contribute to enhancing cyber-security in Fin-tech Services?
2. What specific mechanisms within Management Control Systems act as proactive deterrents against unauthorized access, fraudulent transactions, and other cyber risks in the Fin-tech sector?
3. In the context of Fin-tech Services, what are the nuanced relationships and synergies between Forensic Accounting, Management Control Systems, and cyber fraud?
4. How can insights gained from the impact evaluation of Management Control Systems on cyber fraud inform the development of strategies to enhance overall cyber resilience in Fin-tech?
5. To what extent can the incorporation of emerging technologies such as Artificial Intelligence, Block-chain, Cloud computing, and Big Data into Forensic Accounting contribute to innovative cyber-security strategies within the Fin-tech industry?

### **Significance of the study**

The significance of this study lies in its potential to offer substantial contributions to various dimensions of the financial and technological landscape, particularly within the Fin-tech sector.

#### ***A. The Key Aspects of Its Significance Include***

1. *Strengthening Financial Security:* The Fin-tech industry stands to benefit greatly from the research's significant contribution to financial security enhancement. It looks at how Forensic Accounting and Management Control Systems interact to find ways to strengthen financial systems against the growing threats that cyber-criminals are posing.

2. *Building Cyber Resilience Strategies:* By thoroughly analysing how Management Control Systems affect cyber-crime, this research aims to offer useful information for creating effective cyber-resilience plans. This could provide Fin-tech companies the ability to proactively fix vulnerabilities and effectively counter new cyber-threats.
3. *Increasing Expertise in Financial Practices:* The goal of the project is to increase professional and scholarly understanding in the fields of management control systems and forensic accounting. The research intends to provide a sophisticated understanding that can guide more effective financial management and fraud prevention practices by dissecting their complex relationships.
4. *Including Emerging Technologies:* The research's prospective methodology, which investigates how to include Big Data, Block-chain, Artificial Intelligence, and Cloud computing into forensic accounting, indicates how important it is to keep up with the times. This puts the study at the forefront of reducing potential cyber dangers in addition to addressing current issues.
5. *Informing Policy Development:* It is anticipated that the results of this study would influence the creation of policies in the Fintech industry. These findings can be used by regulatory agencies, legislators, and business professionals to create policies that support a safe and stable financial ecosystem while guaranteeing adherence to changing technology environments.
6. *Bridging Traditional and Technological Practices:* The study attempts to close the gap between established practices and the changing demands of the Fin-tech industry by examining the junction of traditional accounting procedures with state-of-the-art technologies. This has real-world ramifications for professionals and organizations, helping them to embrace new strategies to stay competitive in a world that is changing quickly.

This study is important because, in addition to its theoretical contributions, it has the potential to have a direct impact on operational strategies, security protocols, and policy frameworks in the Fin-tech industry. It aims to be a force for good, promoting an increasingly safe, flexible, and robust future for financial services in the age of rapid technological development. This study explores how combining Forensic Accounting with Management Control Systems (MCS) can strengthen cyber-security in Fin-tech Services. It assesses how MCS can proactively deter and prevent cyber fraud. The research dives into the relationships among Forensic Accounting, MCS, and cyber threats in Fin-tech, aiming to provide practical insights for improving overall cyber resilience. Additionally, it explores how emerging technologies like AI, Block-chain, Cloud computing, and Big Data can be integrated into Forensic Accounting for innovative cyber-security strategies. The study's findings are expected to inform policies and practices in the Fin-tech sector, bridging the gap between traditional and modern approaches.

## **Inference**

In the accounting profession, forensic accounting is a rapidly growing field. The current litigious corporate environment, as well as the rising amount of fraudulent business activities, are factors contributing to this development. This comprehensive research methodology integrates both quantitative and qualitative approaches, allowing for a nuanced exploration of the complex relationships and challenges in the realm of financial security and cyber security within the fin-tech industry.

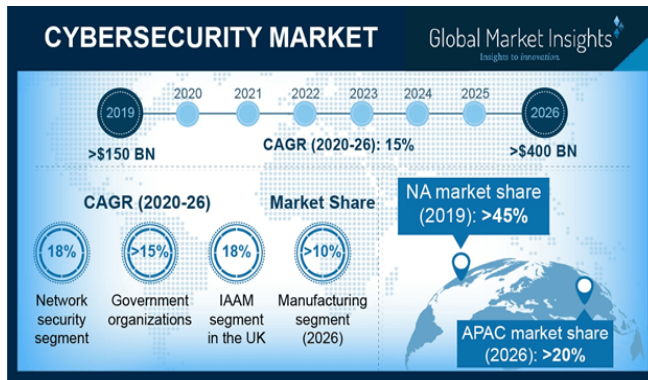
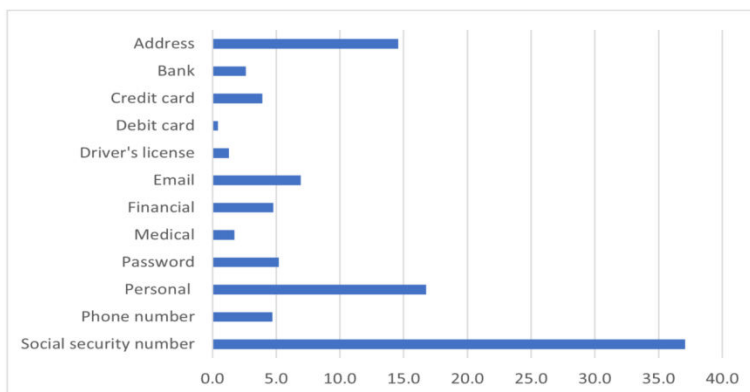

Fig.3 Cyber-security Market

To give a clear understanding on MCS, as a fraud mitigating tool, forensic accounting can detect both internal and external fraud schemes. It has a framework for information gathering, fraud investigation, data analytics, risk assessment, fraud detection and litigation. Strong authentication & authorization mechanisms are critical for protecting user accounts & preventing unauthorized access. Multi-factor Authentication [MFA], biometrics & risk-based authentication can enhance security by adding additional layers of verification. Finding synergy in forensic accounting and cybersecurity is a very challenging task.

Similarly, forensic accountants are specially trained and adept at ferreting out business misconduct, unusual trends, financial anomalies, misappropriation of assets, and remediating related control weaknesses. Many IoT devices have poor security, and they can be easily compromised by attackers. This can lead to data breaches and the compromise of other systems on the network. The Persistent Problem of Fraud Committed Online: The findings of this study highlight the pervasiveness of cyber fraud as an intimidating kind of economic crime on a global scale. Due to the fact that it is persistent, businesses are going to need to continually modify and improve their defences in order to ward off sophisticated cyber assaults. Concerns Regarding Resources and Active Participation: The fact that people are worried about whether or not their local law enforcement agencies have sufficient resources brings to light an important shift in the duty for warding off cyber dangers onto the organisations themselves. Because of this, it is necessary to take a preventative and collaborative approach to the construction of strong cyber security frameworks.

TABLE I HIGHLIGHT THE PERVASIVENESS OF CYBER FRAUD



Additionally, the sheer number of IoT devices and the amount of data they generate can make it difficult to detect and respond to security incidents. By using AI, accountants can perform financial forecasting with higher accuracy, taking various market variables and historical data into account. Cash Flow Management: AI can assist in monitoring and optimizing cash flow, helping businesses maintain healthy financial liquidity.

A Holistic Method is Recommended because: In summing up, the research suggests that traditional methods of accounting should be abandoned in favour of a more comprehensive strategy for achieving monetary stability. For the purpose of formulating effective defences against cyber threats in this day and age, it is considered very necessary to close the knowledge gap that exists between long-standing practises and emerging technology.

Practical insights that might inform strategies, regulations, and practises to create a more secure and resilient future for the fin-tech sector are provided by this research. In essence, this research asks for a dynamic and collaborative posture in the face of increasing cyber threats. Incorporation of New and Evolving Technologies: The forward-looking viewpoint of incorporating emerging technologies into forensic accounting practises, such as artificial intelligence (AI), blockchain, cloud computing, and big data, holds promise for the development of creative cybersecurity solutions. This acknowledgement of technical improvements places the research at the forefront of addressing future concerns since it puts current problems in context.

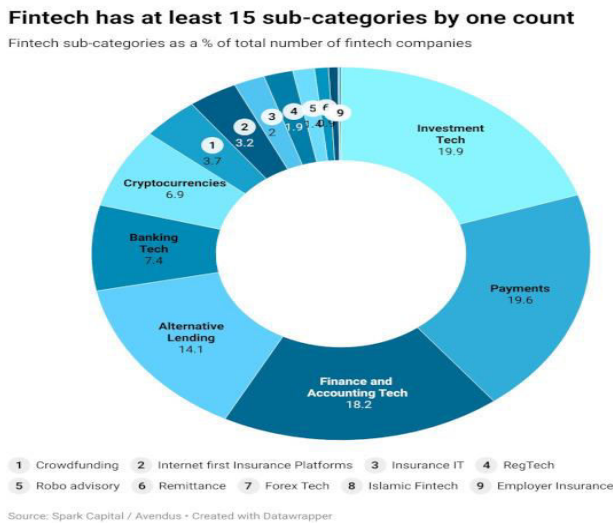

Fig.4 Sub-categories by one count

### Examination of Complicated Relationships

The research goes beyond the typical bounds to investigate the complex links that exist between forensic accounting, management control systems, and computer fraud, particularly as they pertain to the environment of the fintech industry. Our comprehension of the complexities involved has been significantly enhanced as a result of this sophisticated investigate. The Significance of Forensic Accounting and the MCS: The report highlights the essential role that forensic accounting and management control systems play in tackling the expanding danger posed by cyber fraud and highlights the importance of these roles. Their responsibilities go beyond the

conventional aspects of financial management and include the identification, prevention, and investigation of improper financial behaviour.

## Conclusion

The outcome of this in-depth analysis highlights how critical and complex it is to combat cyber-crime inside the dynamic and ever-evolving finance industry. The primary inferences that may be derived from the findings are elaborated on in the following sections:

The dual role that technology plays is brought to light by the association between the rise in the incidence of cyber fraud and the broad adoption of technology in the operations of businesses. Even though it improves productivity, it also adds vulnerabilities, which makes it necessary to strike a cautious balance and take preventative security measures. When one delves deeper into the theoretical underpinnings, one discovers that the distinction between statutory auditors and forensic auditors highlights the distinctive contributions made by the latter. When it comes to improving corporate governance and reducing fraudulent activity, forensic auditors are becoming increasingly important players. According to the findings of the empirical research, there is a significant negative influence that forensic audits have on the occurrence of fraud cases and the engagement of workers in illegal activities. This shows that companies who use forensic audit practise see tangible benefits in reducing instances of fraudulent behaviour within their organization.

## References

- [1] Abala, D. (2014). Foreign Direct Investment and Economic Growth: An Empirical Analysis of Kenyan Data. *DBA African Management Review*, 4(1), 62-83.
- [2] Ahmad, S. (2015). Green Human Resource Management: Policies and practices. *Cogent Business & Management*, 2(1), 1030817. <https://doi.org/10.1080/23311975.2015.1030817>
- [3] Alfaro L., A. Chanda, S. Kalemli-Ozcan & S. Sayek. (2003). FDI and Economic Growth: The Role of Local Financial Markets. *Journal of International Economics*, 12(2), 219-227.
- [4] Analytical and Theoretical Perspectives on Green Human Resource Management: A Simplified Underpinning. (n.d.). Retrieved February 25, 2021, from [https://www.researchgate.net/publication/310743543\\_Analytical\\_and\\_Theoretical\\_perspective\\_on\\_Green\\_Human\\_Resource\\_Management\\_A\\_Simplified\\_Underpinnin](https://www.researchgate.net/publication/310743543_Analytical_and_Theoretical_perspective_on_Green_Human_Resource_Management_A_Simplified_Underpinnin).
- [5] Ari, E., Karatepe, O., Rezapouraghdam, H., & Avci, T. (2020). A Conceptual Model for Green Human Resource Management: Indicators, Differential Pathways, and Multiple Pro-Environmental Outcomes. *Sustainability*, 12. <https://doi.org/10.3390/su12177089>
- [6] Asiedu, E. (2002). On the determinants of foreign direct investment to developing countries: Is Africa different? *World development*, 30 (1), 107-119.
- [7] Behera, H., Narasimhan, V. & Murty, K.N. (2008). Relationship between Exchange Rate Volatility and Central Bank Intervention. *An Empirical Analysis for India*. *South Asia Economic Journal*, 4(2), 12-19
- [8] Bende-Nabende, A., J. Ford, B. Santoso, and S. Sen (2003). The Interaction between FDI, Output and the Spillover Variables: Co-integration and VAR Analyses for APEC, 1965. *Applied Economics Letters*, 10 (3), 1-4
- [9] Bombiak, E., & Marciniuk-Kluska, A. (2018). Green Human Resource Management as a Tool for the Sustainable Development of Enterprises: Polish Young Company Experience. *Sustainability*, 10(6), 1739. <https://doi.org/10.3390/su10061739>
- [10] Buckley, P. J. & Casson, M. C. (1976). The internalization theory of the multinational enterprise: A review of the progress of a research agenda after 30 years. *Journal of International Business Studies* 40 (9), 1563-1580

- [11] Chan, E. S. W., & Hawkins Rebecca, R. (2010). Attitude towards EMSs in an international hotel: An exploratory case study. *International Journal of Hospitality Management*, 29(4), 641–651. doi:10.1016/j.ijhm.2009.12.002.
- [12] Charkrabarti, A. (2001). The Determinants of Foreign Direct Investment: Sensitivity Analyses of Cross-Country Regressions.
- [13] Chingarande, A. (2011). The Impact of Interest Rates on Foreign Direct Investment: A Case Study of the Zimbabwean Economy. *International Journal of Management Sciences and Business Research*,1(5), 2226-8235)
- [14] Cuthbertson, K. (2004). *Quantity Financial Economics: Stocks, bonds and Foreign Exchange*. Chichester: Wiley Corporation.
- [15] Denisia, V. (2010). Foreign direct investment theories: an overview of the main FDI theories, *European Journal of Interdisciplinary Studies*.1(1), 1-8
- [16] Green Human Resources Management—Meaning & Definition | e-CSR.net. (n.d.). You matter. Retrieved February 15, 2021, from <https://youmatter.world/en/definition/green-human-resources-management-meaningdefinition/>
- [17] Guerci, M., Longoni, A., & Luzzini, D. (2015). Translating stakeholder pressures into environmental performance – the mediating role of green HRM practices. *The International Journal of Human Resource Management*, 27, 1–28. <https://doi.org/10.1080/09585192.2015.1065431>.
- [18] Hosain, M. (2016). Green Human Resource Management: A Theoretical Overview. *IOSR Journal of Business and Management (IOSR-JBM)*, 18, 54–59. <https://doi.org/10.9790/487X-1806035459>
- [19] Milliman, J., & Clair, J. (1996). Best Environmental HRM Practices in the US. In W. Wehrmeyer (Ed.), *Greening People, Human Resources and Environmental Management*. Sheffield: Greenleaf Publishing.
- [20] Renwick, D., Redman, T., & Maguire, S. (2008). Green HRM: A Review, Process Model, and Research Agenda. University of Sheffield Working Paper. Retrieved from <http://www.sheffield.ac.uk/content/1/c6/08/70/89/2008-01.pdf>

# Revolutionizing Higher Education: Unleashing Knowledge Management and Artificial Intelligence in Library Services

Parre Ramya

Dr. B.R. Ambedkar Open University, Hyderabad, Andhra Pradesh, India

E-mail: ramyasree560@gmail.com

## Abstract

*With the advent of digital technologies and rapid technological advancements like Artificial Intelligence (AI), Machine Learning (ML), and Generative AI, the landscape of higher education is undergoing a revolutionary transformation. Artificial Intelligence (AI) stands out as a cutting-edge technological trend in the realm of digital transformation (DT) that the new era libraries can leverage to offer innovative educational services. AI has the potential to facilitate smart decision-making processes in accessing and disseminating information, thereby enhancing the learning and research experiences of library users. This paper explores the pivotal synergy of Knowledge Management (KM) and Artificial Intelligence (AI) in reshaping library services to meet the evolving needs of academia. Also, the study covers the foundational importance of KM& AI in fostering collaboration, innovation, and effective decision-making within higher education institutions. Integration of AI into library services emerges as a catalyst for KM in enhancing academic research and content curation, creating a dynamic intellectual environment. This paper presents an overview of AI applications in libraries, ranging from knowledge discovery and recommendation systems to automated cataloging, metadata enhancement, and intelligent tutoring systems. The incorporation of Natural Language Processing (NLP) facilitates seamless user interaction, while AI-driven content curation redefines the landscape of academic research. This paper outlines the applications& use cases of AI in libraries, exploring the realms of AI. It also provides an insight into the transformative power of Generative AI in content creation and the dynamic role in pattern recognition, and intelligent information retrieval. Digital virtual assistants and chatbots driven by AI can potentially provide an unprecedented user support, making library services more accessible and user-friendly. While this paper highlights the efficiency and accuracy brought about by AI in information retrieval and resource utilization, fostering a collaborative learning environment, it also critically addresses the challenges associated with implementing AI in libraries, encompassing ethical considerations, staff training, financial constraints, and the imperative need for unbiased applications. In conclusion, this paper highlights the indispensable role of KM and AI in transforming higher education libraries. It offers a balanced perspective, acknowledging the opportunities while meticulously addressing the challenges. As we look to the future, we discuss emerging trends in AI for libraries, provide recommendations for further research, and emphasize the evolving role of libraries as they embrace and integrate AI technologies. The pursuit of knowledge and innovation in this digital age requires a harmonious blend of traditional wisdom and cutting-edge technologies, and this paper charts a course for libraries to navigate this dynamic landscape successfully, paving the way for a more inclusive, innovative, and high-quality educational ecosystem.*

**Keywords:** Knowledge Management (KM), Artificial Intelligence (AI), Digital Technologies (DT), Machine Learning (ML), Higher Education, Library Services.

## Introduction

The landscape of higher education is undergoing a revolutionary transformation, spurred by the relentless pace of technological advancement and the ever-changing needs of learners and academicians. In this dynamic context, the effective management of knowledge has emerged as a backbone for academic institutions striving to enhance the quality of education they provide. The



foundational work of Dalkir (2013), a comprehensive treatise, *Knowledge Management in Theory and Practice* provides a theoretical framework that is particularly pertinent to understanding the intricate dynamics of knowledge within educational contexts. Knowledge Management (KM) assumes heightened importance in the educational domain as it becomes the catalyst for efficient knowledge creation, dissemination, and utilization. The present study delves into how KM, as a strategic approach, plays a pivotal role in shaping the quality of education by fostering collaborative learning, informed decision-making, and the seamless exchange of knowledge within academic communities. Moreover, it extends beyond the realms of traditional knowledge management, venturing into the transformative domain of Artificial Intelligence (AI).

In the context of libraries — strong repositories of knowledge — AI emerges as a game-changer, promising to revolutionize the way information is accessed, curated, and disseminated. The integration of AI into library services signifies not just an evolution but a revolution in the very essence of how knowledge is harnessed and made accessible. A symbiotic relationship between KM and AI can be observed, exploring how their convergence not only addresses the evolving needs of higher education institutions but also propels them into an era of unparalleled efficiency, adaptability, and enriched learning experiences. The fusion of these two transformative forces holds the promise of reshaping the educational landscape, ensuring that institutions are not just equipped to meet contemporary challenges but are also poised to lead in a future where knowledge is not just acquired but dynamically managed and leveraged for academic brilliance.

This study is based on the qualitative content analysis to explore existing literature on the impact of AI adoption on innovative services across diverse organizations in the digital landscape to derive potential solutions to enhance AI service innovation and information dissemination in Higher education institutions.

### **Knowledge Management**

Knowledge is a dynamic mix of structured experiences, ingrained values, contextual information, and expert insights. This cohesive blend not only forms a framework for understanding and assimilating new experiences and information but also serves as the base for evaluating their significance in a broader context. Knowledge can be broadly categorized as Tacit knowledge (refers to subjective & experiential knowledge like technical skills, cognitive skills, beliefs, perceptions, mental models, etc.) & Explicit knowledge (refers to objective & rational knowledge that can be expressed through theoretical approach, problem solving, manuals, database, etc.). Knowledge Management is a process of creating, storing, sharing and reusing organizational knowledge (know-how) to enable an organization to achieve its goals and objectives. “Knowledge Management is a discipline that promotes an integrated approach to identifying, managing and sharing all of an enterprise’s information assets i.e., databases, documents, policies and procedures, as well as previously unarticulated expertise and experiences resident in individual workers”. (*Gartner Group Inc, 1996*). KM is the activity which is concerned with strategy and tactics to manage human-centered assets. (*Brooking*). In short, KM deals with creating, securing, capturing, coordinating, combining, retrieving and distributing knowledge, both explicit and tacit. Knowledge Management (KM) encompasses knowledge from both external and internal sources, incorporating documents and databases.

Implementing knowledge management aims to foster the growth, transfer, and sharing of knowledge within the organization, boost innovation, elevate organizational performance, enhance employee contributions to knowledge assets, increase internal visibility, gain a competitive edge, and improve overall employee effectiveness and efficiency.

#### *A. Goals of Knowledge Management (KM)*

1. *Creation of Knowledge Repositories:* Involves storing both knowledge and information, including external knowledge, structured internal knowledge (e.g., research reports, product-oriented marketing materials), and informal or tacit knowledge (e.g., discussions databases capturing "know-how").
2. *Improvement of Knowledge Access and Transfer:* Focuses on enhancing connectivity, access, and transfer of knowledge. Utilizes technologies such as video conference systems, document scanning, sharing tools, and telecommunication networks.
3. *Enhancement of the Knowledge Environment:* Aims to create a conducive environment for effective knowledge creation, transfer, and utilization includes initiatives like increasing awareness of knowledge-sharing, providing awards for contributions to the organization's structured knowledge base, and assessing how employees apply knowledge in key decisions.
4. *Management of Knowledge as an Asset:* Involves recognizing knowledge as a valuable organizational asset. Emphasizes understanding the value of knowledge to the organization and implementing structures and cultures that support successful knowledge management. (Poonkothai, 2016).

The process of knowledge management (KM) involves the discovery and detection of knowledge, categorized as explicit, tacit, and embedded. Subsequently, knowledge organization and assessment occur across these knowledge types. Additionally, knowledge sharing is facilitated through explicit, tacit, and embedded knowledge, all integrated with Information Technology (IT) for effective dissemination and utilization.

### **Artificial Intelligence**

#### *A. Definitions & Scope*

Artificial Intelligence (AI) involves replicating human intelligence in computers and machines. This multidisciplinary field of computer science concentrates on creating algorithms, software, and hardware capable of executing tasks that traditionally demand human intelligence. AI systems strive to emulate various human cognitive functions, including learning, reasoning, problem-solving, perception, and language understanding. 'AI is the ability of a computer system to solve problems and perform tasks that would otherwise require human intelligence'. (US National Security Commission on AI, 2021). Artificial intelligence (AI) is 'a machine-based system that can, for a given set of human defined objectives, make predictions, recommendations, or decisions influencing real or virtual environments. AI systems are designed to operate with varying levels of autonomy'. (OECD, 2020). AI encompasses Machine Learning, Deep Learning, Natural Language Processing, Computer Vision, Robotics, Expert Systems, Reinforcement Learning, and AI Ethics. Its applications span healthcare, finance, education, entertainment, and transportation.

#### *B. Integration of AI & KM in Library Services*

Symbiosis of Knowledge Management & Artificial Intelligence in libraries involves the implementation of intelligent systems and algorithms to enhance various aspects of library operations. This includes cataloging, information retrieval, user assistance, and decision-making processes. Intelligent systems can analyze vast amounts of data, leading to more efficient and effective library services. One of the key roles of AI in libraries is to facilitate knowledge discovery. Advanced algorithms can analyse user behaviour, preferences, and past interactions to recommend relevant materials. Natural Language Processing (NLP) enables AI systems to understand and respond to user queries, improving the search and retrieval of information. Furthermore, AI supports the dissemination of knowledge by automating the categorization and tagging of resources, making them more accessible to users.

### C. Use Cases of AI in Library Services

1. *Knowledge Creation, Storage, Discovery and Recommendation Systems*: AI algorithms analyze user behavior, historical data, and reading patterns to recommend personalized content. It enhances knowledge discovery by suggesting relevant resources by sifting through organizational data and discovering relationships, thereby improving user engagement (Smith, 2018).
2. *Automated Cataloging and Metadata Enhancement*: AI automates the cataloging process by employing computer vision to recognize book covers, extract metadata, and classify resources accurately. This streamlines library operations and ensures consistent data quality (Jones *et al.*, 2020).
3. *Intelligent Tutoring Systems for Personalized Learning Experiences*: AI-driven tutoring systems adapt to individual learning styles. By assessing user performance, these systems provide tailored learning materials, quizzes, and exercises, fostering a personalized educational journey (Clark & Mayer, 2016).
4. *Natural Language Processing (NLP) Applications in User Interaction*: NLP enables natural and conversational interactions between users and library systems. Chatbots equipped with NLP capabilities offer assistance, answer queries, and guide users in locating resources efficiently (Manning *et al.*, 2014). They can also summarize, and provide the relevant details to the library patrons in a real time basis. These systems utilize natural language understanding to assist with queries, guide users through library services, and provide information on available resources.
5. *AI-Driven Content Curation for Academic Research*: AI analyzes research trends, citation patterns, and user preferences to curate relevant academic content. This aids researchers in discovering high-impact resources, saving time in the literature review process (Borgman, 2015). Generative AI algorithms, such as GPT models, contribute to content creation by autonomously generating human-like text. This technology assists in the development of summaries, abstracts, and even creative content like poetry and narratives (Brown *et al.*, 2020).
6. *Automated Information Extraction and Summarization*: AI tools utilize natural language processing to extract and summarize information from lengthy texts. This facilitates quick comprehension of articles, research papers, and other textual resources, improving accessibility (Jurafsky & Martin, 2019).
7. *Predictive Analytics for Collection Development*: AI employs predictive analytics to forecast future resource demands. Analysis of usage patterns and emerging research areas helps libraries strategically enhance their collections, optimizing resource allocation (Provost & Fawcett, 2013).
8. *Enhanced Accessibility through Voice Recognition*: Voice-enabled AI technologies enhance accessibility, allowing users to interact with library catalogs through voice commands. This inclusivity benefits individuals with disabilities, providing a more accessible library experience (Deng & Li, 2018).

### Tools Empowering Km and Ai Integration

AI-powered tools are crucial for improving Knowledge Management (KM) and making library processes more efficient. Here are some key tools for librarians:

1. *Integrated Library Systems (ILS)* are the comprehensive systems that centralize library functions such as cataloging, circulation, and acquisitions. They can integrate with AI modules to optimize resource management. (Breeding, 2016)
2. *Open KM* is an open-source document management system whose AI capabilities include content categorization, aiding librarians in efficient organization and retrieval.

3. *Zotero* is a reference management tool that assists in citation management and bibliography creation. AI integration improves citation suggestions.
4. *Koha* is an open-source ILS with modules for cataloging and circulation. AI integration optimizes collection development and user engagement.
5. *Microsoft Academic & Deep Dyve* employs AI for semantic search, aiding librarians in discovering relevant academic resources. *Reference: Microsoft Academic. (Microsoft Academic, 2023).*
6. *Lib Chat* powered by AI, provides intelligent chatbot services for libraries, assisting users and enhancing engagement.
7. *Tableau* with AI integration, offers advanced analytics and data visualization for librarians to gain insights into library usage patterns, and that can help in better resource & collection planning.

### **Benefits**

The fusion of AI & KM within libraries yields a multitude of advantages, significantly influencing user engagement and operational efficiency. Here are a few major benefits:

1. *Enhanced Accessibility and Tailored Content Recommendations* by delivering personalized content suggestions based on user preferences and historical interactions, thereby optimizing their overall experience.
2. *Improved User Experience* through AI-Driven Interfaces like Chatbots and virtual assistants which engage users in natural language interactions, addressing queries, guiding, and presenting a user-friendly interface.
3. *Streamlined and Accurate Information Retrieval* through advanced search capabilities, ensuring more precise and efficient information retrieval.
4. *Efficient Time Management in Research and Resource Utilization* through automation of cataloging, metadata enhancement, and routine tasks accelerates library workflows.
5. *Promotion of Collaborative Learning Environments* by facilitating knowledge sharing and interaction among users. Intelligent tutoring systems provide users with personalized learning experiences, contributing to a collaborative and engaging educational environment.

### **Challenges in Implementing AI in Libraries**

The introduction of Artificial Intelligence (AI) in libraries presents a set of challenges that demand careful consideration (Ashikuzzaman, 2023, Tene, O., & Polonetsky 2012):

1. *Ethical Considerations & Privacy Concerns:* Ethical questions surrounding data privacy and user consent emerge with the utilization of AI, necessitating a delicate balance between personalized services and safeguarding privacy rights.
2. *Staff Training & Technological Readiness:* The successful integration of AI requires a proficient workforce, highlighting the importance of staff training to ensure librarians can effectively use AI tools and comprehend their implications.
3. *Financial Implications and Resource Constraints:* The adoption of AI technologies entails financial investments, posing challenges for libraries, especially those with limited budgets, to incorporate these technologies while sustaining essential services.
4. *Ensuring the Inclusivity and Unbiased Nature of AI Applications:* AI algorithms, based on training data, may inadvertently perpetuate biases, emphasizing the need for libraries to actively ensure inclusivity, unbiased outcomes, and the avoidance of unintentional discrimination.

5. *Integration Challenges with Existing Library Systems*: The integration of AI with established library systems, including cataloging and circulation, presents challenges that may necessitate significant adjustments to ensure seamless compatibility.

Addressing these challenges requires a holistic strategy, encompassing technological solutions, organizational policies, and user engagement efforts. A thoughtful and ethical approach is paramount as libraries navigate the AI landscape to maximize benefits while mitigating potential drawbacks.

### **Conclusion and Future Directions**

In conclusion, this analytical review paper asserts the potential possibilities of AI & KM integration and its indispensable role in transforming higher education. This recalibration positions librarians to strategically leverage AI for efficient resource management, paving the way for a dynamic and collaborative knowledge environment. The collaboration between AI and Knowledge Management (KM) not only enhances accessibility, personalizes services, and optimizes resource management but also contributes to a more inclusive and diverse library ecosystem. Librarians, as active leaders in this transformative journey, need to embrace AI as a tool that propels them into new and innovative roles. While challenges such as ethical considerations and staff training persist, the potential benefits in terms of improved accessibility, efficient information retrieval, and enhanced user experiences are substantial. Looking forward, the impact of artificial intelligence is transforming traditional librarian roles, requiring active leadership in integration. Embracing AI offers opportunities for librarians to assume innovative positions and address contemporary challenges. Shifting focus from traditional tasks to adopting technology is key for librarians to stay relevant in meeting the evolving needs of the upcoming generation. Libraries must continually integrate AI technologies, aligning with the broader goals of educational institutions. By staying at the forefront of technological advancements, libraries can proactively contribute to vibrant and adaptive knowledge hubs.

### **References**

- [1] Alavi, M., & Leidner, D. E. (2001). Knowledge management and knowledge management systems: Conceptual foundations and research issues.
- [2] Borgman, C. L. (2015). *Big Data, Little Data, No Data: Scholarship in the Networked World*. MIT Press.
- [3] Brown, T. B., Mann, B., Ryder, N., Subbiah, M., Kaplan, J., Dhariwal, P., & Agarwal, S. (2020). Language Models are Few-Shot Learners. arXiv preprint arXiv:2005.14165.
- [4] Brynjolfsson, E., & McAfee, A. (2014). *The Second Machine Age: Work, Progress, and Prosperity in a Time of Brilliant Technologies*.
- [5] Chen, H., Chiang, R. H., & Storey, V. C. (2012). *Business Intelligence and Analytics: From Big Data to Big Impact*.
- [6] Chollet, F., et al. (2015). *Keras, Knowledge Management in Libraries*.
- [7] Clark, R. C., & Mayer, R. E. (2016). *e-Learning and the Science of Instruction: Proven Guidelines for Consumers and Designers of Multimedia Learning*. Wiley.
- [8] Dalkir, K. (2013). *Knowledge Management in Theory and Practice*.
- [9] Deng, L., & Li, J. (2018). *Deep Learning in Natural Language Processing*. Springer.
- [10] Floridi, L., & Sanders, J. W. (2004). On the Morality of Artificial Agents.
- [11] Jarrahi, Mohammad Hossein & Askay, David & Eshraghi, Ali & Smith, Preston, 2023. "Artificial intelligence and knowledge management: A partnership between human and AI," *Business Horizons*, Elsevier, vol. 66(1), pages 87-99.
- [12] Johnson, L., Adams Becker, S., Estrada, V., & Freeman, A. (2015). *NMC Horizon Report: 2015 Higher Education Edition*. Austin, Texas: The New Media Consortium.

- [13] Jones, P., Ferguson, J., & Martinez-Urbe, L. (2020). *Artificial Intelligence: A Guide for Thinking Humans*. Allen Lane.
- [14] Manning, C. D., Raghavan, P., & Schütze, H. (2014). *Introduction to Information Retrieval*. Cambridge University Press.
- [15] Marshall Breeding. (2016). *Library Technology Reports*.
- [16] McCarthy, J., Minsky, M. L., Rochester, N., & Shannon, C. E. (2006). A proposal for the Dartmouth Summer Research Project on Artificial Intelligence.
- [17] MD. Ashikuzzaman Application of AI in Libraries: A Comprehensive Study on the Integration and Impact of Artificial Intelligence in Library
- [18] OECD (2020) The OECD AI principles. Available at: [https:// oecd.ai/en/ai-principles](https://oecd.ai/en/ai-principles)
- [19] Poonkothai. R. (2016), Knowledge Management as an important tool in Library Management
- [20] Provost, F., & Fawcett, T. (2013). *Data Science for Business: What You Need to Know about Data Mining and Data-Analytic Thinking*. O'Reilly Media.
- [21] Russell, S. J., & Norvig, P. (2009). *Artificial Intelligence: A Modern Approach*.
- [22] Smith, A. N. (2018). *The Age of Surveillance Capitalism: The Fight for a Human Future at the New Frontier of Power*. Public Affairs.
- [23] Tene, O., & Polonetsky, J. (2012). Privacy in the age of big data: A time for big decisions.
- [24] US National Security Commission on AI (2021) Final report. Available at: <https://www.nsc.gov/2021-final-report/>

# Applications of Big Data Tools in Libraries

**J. Arumugam<sup>1</sup>, R. Abraham Dinesh<sup>2</sup> and S. Meganathan<sup>3</sup>**

<sup>1</sup>Librarian, <sup>2&3</sup> Library Intern

<sup>1,2&3</sup>PSG College of Technology, Coimbatore, Tamil Nadu, India

E-mail: jam.lib@psgtech.ac.in

## Abstract

*Big data analytics tools play a significant role in libraries by revolutionizing the way libraries manage and utilize information. These tools leverage the power of advanced data processing techniques to extract meaningful insights from the vast amounts of data that libraries collect and generate. This paper discusses about the need, significant role of big data tools in library applications and also provides a list of different types of big data analytics tool and its pros and cons in using in libraries. This paper also attempts to analyse the impact of big data applications in libraries.*

**Keywords:** Big data analytics, Innovative library services, Elastic search, Hadoop, Open Refine, Python, Tableau

## Introduction

Big data analytics is a valuable tool for libraries to gain insights into their resources and services, and to make data-driven decisions that improves user experience. Big data analytics can help libraries analyze their collection usage data to determine which resources are most frequently used, which items are not being used and can be weeded out, and which items are in high demand but are not currently available. This information can be used to make informed decisions about collection development and management. Big data analytics can help libraries understand how users interact with their services, such as how frequently they access specific resources or how long they spend on certain web pages, and even book circulation to users. This information can be used to optimize user experience and make improvements to library services. Applying big data analytics on this information can help libraries to identify patterns and trends in how users search for resources. This information can also be used to improve resource discovery tools and make it easier for users to find what they are looking for. Big data analytics can help libraries monitor the performance of their systems and services in real-time, identifying issues before they become significant problems. This information can be used to maintain high levels of service availability and prevent downtime.

## Need of Big Data in Libraries

Big data refers to extremely large and complex data sets that can be analyzed to reveal patterns, trends, and associations. Libraries have traditionally been repositories of information and knowledge, and the rise of big data has created new opportunities for libraries to play a critical role in managing and utilizing this vast amount of data. Big data can help libraries operate more efficiently, better serve their users, and contribute to the overall development of their communities. As such, it is increasingly important for libraries to develop the necessary skills and infrastructure to manage and utilize big data effectively. By analyzing data on how patrons use library resources and services, libraries can make informed decisions about how to improve their offerings and provide a better user experience. In addition to this, applying big data analytics on libraries can help them make accurate decisions about which materials to acquire, how to allocate resources, and how to promote their collections.

Moreover, big data can help libraries optimize their operations and allocate resources more effectively. By analyzing data on library usage patterns and user behavior, libraries can identify areas where resources are being underutilized and make adjustments to improve efficiency. It can help libraries identify new opportunities for outreach and engagement with their communities. Analyzing data on community demographics, social media usage, and other factors, can help libraries develop targeted outreach strategies that are more likely to resonate with their audiences.

### **Big Data Tools for Libraries**

The following are some of the big data tools that libraries can use to manage and analyze their data. It is important to choose the right tools, from this list, based on the library's needs and resources, while also developing the necessary skills and infrastructure to use these tools effectively: Hadoop, Apache Spark, Elasticsearch, Tableau, OpenRefine and Python.

### **Hadoop for Libraries**

Hadoop is an open-source framework that allows libraries to store, process, and analyze large datasets. It is designed to work with distributed data and can handle data of various types and formats. However, it is important to note that Hadoop requires specialized skills and infrastructure to set up and maintain. Libraries may need to invest in training and infrastructure to use Hadoop effectively the following library purposes:

- 1. Data Storage:* Hadoop Distributed File System (HDFS) allows libraries to store and manage large datasets across multiple servers. HDFS is fault-tolerant and can handle petabytes of data.
- 2. Data Processing:* Its Map Reduce framework allows libraries to process large datasets parallelly across multiple nodes. MapReduce is designed to work with large, unstructured datasets and can perform complex computations.
- 3. Data Analysis:* Hadoop's ecosystem includes several tools for data analysis, including Hive, Pig, and Spark. Libraries can use these tools to analyze their data and extract insights.
- 4. Digital Preservation:* Its ability to store and process large amounts of data can be useful for digital preservation efforts. Libraries can use Hadoop to store and process digital assets, such as images, videos, and audio files.
- 5. Resource Optimization:* Hadoop can help libraries optimize their resources by distributing processing and storage across multiple servers. This can improve efficiency and reduce costs.

### **Apache Spark**

Apache Spark is an open-source big data processing engine that can be used for large-scale data processing, machine learning, and data analytics, especially for libraries that need to manage and analyze large datasets. Spark is designed to be fast, easy to use, and scalable, making it suitable for processing large amounts of library data. Similar to Hadoop, Spark requires specialized skills and infrastructure to work with it efficiently.

#### *1. Data processing*

Spark can be used for processing large datasets in parallel across multiple nodes. Spark can handle various data formats and supports data processing in real-time.

#### *2. Data analysis*

Data analysis can be done in Spark SQL, Spark Streaming, and Spark MLlib. Libraries can use these tools to analyze their data and extract insights.

#### *3. Digital preservation*

Spark's ability to process large amounts of data can be useful for digital preservation efforts. Libraries can use Spark to process digital assets, such as images, videos, and audio files.



#### *4. Recommendation systems*

It includes a library for building recommendation systems. Libraries can use this library to recommend resources to their users based on their preferences.

#### *5. Machine learning*

Spark's MLlib library includes several algorithms for machine learning. Libraries can use these algorithms to help build predictive models and make data-driven decisions.

### **Elastic search**

Elasticsearch is an open-source search engine that can be used to index and search large datasets. It is a useful tool for libraries that need to provide fast and accurate search results for their users.

#### *1. Catalog Search*

Libraries can use Elastic search to search their catalog and other resources, such as websites and digital collections. It is specialised to provide fast and accurate search results, improving user experience.

#### *2. Faceted Search*

Elastic search supports faceted search, which allows users to refine their search results by selecting filters. Faceted search can help users find resources more easily and quickly.

#### *3. Recommendation Systems*

Similar to Apache Spark, Elasticsearch can be used to build recommendation systems that recommend resources to users based on their search behaviour.

#### *4. Data Analysis*

It includes tools for data analysis, such as Kibana and Logstash. Libraries can use these tools to analyze their search data and gain insights into user behaviour.

#### *5. Digital Preservation*

Elastic search can be used to index and search digital assets, such as images, videos, and audio files. This can be useful for digital preservation efforts.

### **Tableau**

Tableau is data visualization and business intelligence software that can be used to create interactive visualizations, dashboards, and reports. It is potentially a useful tool for libraries that want to visualize and analyze their data. It can provide insights into user preferences, collection analysis, and outreach and marketing efforts.

#### *1. Usage Statistics*

Libraries can use Tableau to visualize their usage statistics, such as circulation data, database usage, and website analytics. Tableau can provide insights into user behavior and help libraries make data-driven decisions.

#### *2. Collection Analysis*

Tableau can be used to analyze library collections, such as the age and format of items, subject areas, and circulation patterns. Libraries can use these insights to make informed decisions about collection development and weeding.

#### *3. Data Sharing*

Tableau can be used to share data with stakeholders, such as faculty, administration, and library boards. Tableau can provide a visual representation of data, making it easier to understand and communicate.

#### *4. Outreach And Marketing*

Tableau can be used to create visualizations and dashboards that showcase library resources and services. Libraries can use Tableau to highlight the impact of their services and make a case for funding.

### 5. Collaboration

Tableau can be used for collaboration among library staff. Staff can share visualizations and collaborate on data analysis and decision-making.

### Open Refine

OpenRefine, formerly known as Google Refine, is a free and open-source software tool that can be used for data cleaning, transformation, and reconciliation. OpenRefine is a java-based open-source application solely designed to load, understand, clean, reconcile, and transform messy data (*GitHub*, n.d.; *OpenRefine*, n.d.).

#### 1. Data Cleaning

Libraries often have large datasets that need to be cleaned from errors and inconsistencies, and standardized. As such, OpenRefine can be used to clean and standardize data, such as author names, publication dates, and subject headings.

#### 2. Data Transformation

Open Refine can be used to transform data from one format to another. For example, libraries can use OpenRefine to convert MARC records to other formats, such as CSV or JSON. It can also transform the data into another form by transposing the elements within the file. This can be done with ease in matter of minutes.

#### 3. Data Reconciliation

It includes a reconciliation feature that can be used to match data to external databases, such as VIAF or Library of Congress authorities. This can help libraries ensure data accuracy and consistency.

#### 4. Collection Analysis

Open Refine can be used to analyze library collections, such as the frequency of subject headings or the number of duplicate records. Collection development and weeding can be done in libraries effectually using the insights gained from these analyses.

#### 5. Data Sharing

It can be used to share data with stakeholders, such as faculty, administration, and library boards. OpenRefine is a versatile tool to export data in various formats, making it easy to share and collaborate on.

### Python

Python is a popular programming language that can be used for a variety of tasks in libraries. It is a versatile tool for libraries that want to automate tasks, analyze data, and develop web applications. However, Python requires specialized skills and infrastructure to set up, operate and work with it. Libraries may need to invest in training and infrastructure to use Python effectively. Some ways in which it can be utilised by libraries are:

#### 1. Data Analysis And Visualization

Python has powerful libraries for data analysis and visualization, such as Pandas, NumPy, and Matplotlib. As the other tools given above, libraries can use these specific Python tools to analyze their data and create visualizations, such as precise charts and graphs.

#### 2. Web Development

One of the primary functions of Python is that it has several web development frameworks, such as Django and Flask, that can be used to create library websites and applications.

#### 3. Automation

Python can be used to automate repetitive tasks, such as metadata clean-up or data processing. Libraries can use Python to save time and reduce errors, two of the most important tasks of librarians.

#### 4. *Natural Language Processing*

Python has libraries for natural language processing, such as NLTK and spaCy, that can be used for text analysis and search.

#### 5. *Machine Learning*

Python has libraries for machine learning, such as scikit-learn and TensorFlow, that can be used for tasks such as recommendation systems or predictive analytics.

### **Impact of Big Data Applications in Libraries**

Big data applications have significant impact on libraries by improving the user experience, collection analysis, decision-making, efficiency, outreach and marketing, and resource allocation. However, it is important for libraries to have the necessary infrastructure, skills, and resources to effectively implement and maintain big data applications. As discussed above, it provides insights into user behaviour and preferences. Libraries can use this information to tailor their services and resources to better meet the needs of their users. These applications can be used to analyze library collections, such as circulation data and usage statistics. Libraries can use this information to make informed decisions about collection development, weeding, resource allocation, automate repetitive tasks, etc, and finally to save the time of users.

Big data applications can provide libraries with insights into the impact of their services and resources, making it easier to showcase their value to stakeholders and secure funding. These applications can help libraries identify which resources are being underutilized and where to allocate resources more effectively.

### **Cons of Big Data Applications in Libraries**

While big data applications can offer many benefits for libraries, they also present some potential drawbacks, such as data privacy concerns, infrastructure requirements, lack of standardization, risk of bias, and cost. It is important for libraries to weigh them carefully before implementing big data applications.

1. Big data applications can collect a large amount of personal data about library users, which can raise concerns about privacy and data security.
2. Implementing and maintaining big data applications can require significant infrastructure, skills, and resources, which may be difficult for some libraries to acquire and maintain.
3. Big data applications often rely on non-standardized data formats, which can make it difficult to compare and analyze data from different sources.
4. Big data applications can produce biased results if the data used is not representative of the entire population or if algorithms are designed with unconscious biases.
5. Implementing and maintaining big data applications can be expensive, which may be a barrier for some libraries with limited budgets.

### **Conclusion**

Implementing big data applications in libraries can be challenging due to infrastructure requirements, data management, data privacy and security concerns, integration with existing systems, cost, lack of standardization, and the need for cultural change. Libraries must carefully evaluate these implementation hurdles and ensure that they have the necessary infrastructure, skills, and resources to implement big data applications effectively. Implementing big data applications requires significant infrastructure, including hardware, software, and storage capacity. Libraries may need to invest in new infrastructure or upgrade existing infrastructure to support big data applications. Managing and analyzing large amounts of data requires specialized skills and expertise. Libraries may need to hire or train staff to manage and analyze data effectively. However, they often collect and analyze large amounts of personal data, raising concerns about

data privacy and security. Libraries must have strong data protection policies and procedures in place to ensure that user data is kept secure.

Libraries may need to integrate big data applications with their existing library management systems, which can be complex and time-consuming, Implementing and maintaining big data applications can be expensive, which may be a barrier for some libraries with limited budgets. Moreover, Big data applications often rely on non-standardized data formats, which can make it difficult to compare and analyze data from different sources and it may require a cultural shift within the library, as staff may need to adopt new workflows and data analysis practices.

## References

- [1] Blummer, B., & Kenton, J. M. (2019). Big Data and Libraries: Identifying Themes in the Literature. *Internet Reference Services Quarterly*, 23(1-2), 15–40. <https://doi.org/10.1080/10875301.2018.1524337>
- [2] Gibbons, S. (2013). Techniques to understand the changing needs of library users. *IFLA Journal*, 39(2), 162–167. <https://doi.org/10.1177/0340035212472846>
- [3] Git Hub – Open Refine/Open Refine: Open Refine is a free, open source power tool for working with messy data and improving it. n.d. <https://github.com/OpenRefine/OpenRefine>
- [4] Jantti, M. (2016). Libraries and Big Data. In *Quality and the Academic Library: Reviewing, Assessing and Enhancing Service Provision* (pp. 267–273). Chandos Publishing. <https://doi.org/10.1016/b978-0-12-802105-7.00026-9>
- [5] Jantti, M. (2016). Libraries and Big Data. In *Quality and the Academic Library: Reviewing, Assessing and Enhancing Service Provision* (pp. 267–273). Chandos Publishing. <https://doi.org/10.1016/b978-0-12-802105-7.00026-9>
- [6] Kaladhar, A., Naick, B. R. D., & Rao, K. S. (2018). Application of Big Data Technology to Library data: A review. *International Journal of Library and Information Studies*, 8(2), 25–30. [http://www.ijlis.org/img/2018\\_Vol\\_8\\_Issue\\_2/25-30.pdf](http://www.ijlis.org/img/2018_Vol_8_Issue_2/25-30.pdf)
- [7] OpenRefine | OpenRefine. n.d. <https://openrefine.org/>

# Transforming Libraries with Artificial Intelligence: Innovations and Impact

A. Kumarachelvan<sup>1</sup> and Dr. G. Ulaganathan<sup>2</sup>

<sup>1</sup>Research Scholar, <sup>2</sup>Librarian & Head

<sup>1&2</sup>Dept. of Library and Information Science,

<sup>1&2</sup>Dr. SNS Rajalakshmi College of Arts and Science, Coimbatore, Tamil Nadu, India

E-mail: arjunkumarachelvan@gmail.com, drgulaganathan@gmail.com

## Abstract

*The rise of ultramodern society has been mainly powered by artificial intelligence, which has also given the creation of smart libraries new life. This essay explains the background information on smart libraries and artificial intelligence, examines how AI functions in the context of smart libraries, and illustrates how AI might improve library services. Smart library creation is going to utilize significant use of artificial intelligence.*

**Keywords:** Artificial Intelligence, Smart Library, Big Data, Internet, Digital Library

## Introduction

Artificial intelligence, a cutting-edge technological advancement, has completely changed how we distribute, process, access, and use information. Libraries that promote research and academics are adopting new technologies in an effort to improve their offerings and gain a competitive edge. This transition has been largely fueled by artificial intelligence, and in this essay, we'll discuss how AI is influencing experimenters and libraries worldwide.

## Artificial Intelligence

The goal of the large field of computer science known as artificial intelligence is to build intelligent machines that resemble human intelligence. It is currently one of the most amazing and intricate inventions ever made by humans, but the field is still very young and has a lot of room to grow. Three categories of artificial intelligence exist

### 1. Artificial Narrow Intelligence (ANI)

It's the only type of Artificial intelligence we have right now, and it's known as feeble Artificial Intelligence having a limited range of capabilities. Face recognition, speech recognition/voice sidekicks, and bus driving are all applications of artificial narrow intelligence.

### 2. Artificial General Intelligence (AGI)

Robust artificial intelligence that can mimic human thought processes and behaviour to address any issue. Although strong or deep AI is not yet accessible, scientists are trying to make machines more similar to humans in terms of vision, comprehension, and learning.

### 3. Super Intelligence that is Artificial

It is academic Artificial Intelligence that outperforms mortal intelligence and capabilities. It has always been a source of relief for those who fabricate wisdom wherein the world is taken over by robots. Having significant and tone-apprehensive super-intelligent machines may be a good idea, but their impact on humanity remains unknown. For the time being, it will be many years before artificial superintelligence becomes a reality.

## How Artificial Intelligence will Change the Job of Librarians

An increasing number of libraries are incorporating artificial intelligence. Here are some areas where AI will make a big difference.

### *1. Content Indexing*

Until now, indexing has been a time-consuming and amateurish task. It is done in part by publishers and in part by authors. Indexing provides a snapshot of the context in which the book, journal, or paper was first permitted. Yet, indexing still informs us very little about, say, other fields the information could be useful for, and the classification and indexing that mortal made is impeding interdisciplinary discovery. The indexing was done in a specific order in a specific environment, and over time that environment of what we know about the world will change, which limits the literature's ability to remain applicable. AI indexing tools will enhance the quality and thickness. It's got the ability to recognize generalizations and give them matching keywords. Additionally, index robotization will enable the anthology to traverse across disciplines and find new literature—a feature that is not possible with hand-crafted indexing. By providing more precise and targeted content for the indices, these AI tools will outperform human indexers and help university librarians do their jobs better.

### *2. Document Matching*

Artificial intelligence (AI) systems process documents faster and accurately than individuals AI tools are able to understand similarities and differences between documents or patents because of automatic proper indexing. It is now feasible to match documents with similar ones or link sections that discuss related subjects, fixes, or phenomena. You can compare the content of thousands of documents that are contextually relevant to the search topic when a document is indexed based on its actual content. It can be prohibited to specific document sections, like certain chapters in a book or sections of a research paper. Instead of performing a five phrase summary in each section, you then compare the content in these sections to find precisely what you're looking for in the literature.

### *3. Termination of Reference*

Although the citation system can be seen as a popularity contest, it only really serves to present a highly skewed picture of a network of researchers. The citation system for snowballing is not the best way to cover everything, as is evident when conducting literature reviews and research landscape mapping. AI algorithms—as opposed to the network of researchers presented in the citation system—will produce far better mapping systems of the actual research and be extremely helpful to both researchers and librarians because they are based on the actual content of papers.

## **Content Summarization**

The objective of automatic content summarization is to automatically reduce lengthy documents to a manageable length while maintaining the essential ideas and original text's meaning. Artificial intelligence tools can condense a book or five documents into three sentences, rather than summarizing the entire text. In addition to machine learning algorithms that are constantly improving this task, there are already AI tools for content summarizations available online and growing in popularity. Summarizing information automatically comes in two flavors: abstraction and extraction.

### *1. Extrapolated Summary*

In order to perform an extractive summarization, sentences must be taken out of the source text using a scoring system. Based on the statistical survey, it extracts the most significant portions of the input and reorganizes them to create a new, condensed version of the document.

### *2. Abstracted Explanation*

Using advanced natural language techniques, abstract summaries produced a new, epitomized interpretation of the document that was different from the original bone. It aims to add crucial

details, like a mortal-spoken synopsis, and preserve the most important decisions while restating them. Most summaries employ the extractive approach because it is less complex and demands less verbal analysis.

### **Exceptional Service**

Converse bots are one way artificial intelligence (AI) has found a home in the world of experimenters and librarians. These chatbots can notify users of new book releases, provide targeted or straightforward answers, and point users towards particular library resources. When robots take over conversations between stoners and themselves, librarians will have more time to answer the same questions more thoughtfully and with greater nuance. Additionally, this will allow libraries to increase the hours that they are open for both in-person and online services.

### **Future Impact Factor**

The impact factor quantifies how important and high-caliber a particular publication, journal, or experimenter is in relation to the body of literature. The algorithm will eventually be able to dissect scientific research into arguments and compare them to other research projects. Alternatively, it could create a verity tree of justifications and arguments for each document, verify each branch, and determine the total validity score. The number of compendiums is not as significant as the quality of the validated or revised exploration, since the latter is deserving of a wider readership.

### **Increased Efficiency in Operations**

By optimizing service effectiveness and cutting functional costs through process automation, optimized exploration data operation, and Digital Asset Management (DAM), libraries can detect and enhance functional effectiveness. Maintaining machine literacy in the digital coffers and processes of the library can optimise preservation, visualization, and analysis of the collection while lowering service delivery costs. Giving up on cutting-edge library service platforms can aid in the growth of functional efficacy..

### **The future of libraries**

The traditional jobs of librarians are being dismantled by artificial intelligence, which is also changing the geography of information. In order to better serve the upcoming generations, they must embrace AI as an active leader rather than as a stoner. However, a few misgivings prevent AI from being fully integrated into the library industry. While it is understandable to be afraid of being replaced by AI robots, we also need to acknowledge that new technologies will present opportunities for librarians. It will enable them to stay in novel roles and locations, overcome present difficulties, and keep them from developing into dated. The emphasis on traditional tasks needs to be changed to a new path that embraces cutting-edge technologies and helps the next generation with its changing needs.

### **Intelligent Application Service**

The technology used to operate library tone services is currently fairly advanced, and the services themselves come in a variety of rich forms. The primary representatives include the lecture training appointment operation system, the tone service print dupe operation, the self-service seat operation system, the tone service library ATM, etc. The following are some benefits that tone-service operations have over traditional operation services

1. Use artificial intelligence to transcend the boundaries of space and time and provide immediate assistance for no-shows.;

2. reduce the labor and logistical costs associated with library services by broadening the scope of the services and extending their service form;
3. Increase user willingness to participate and safeguard readers' privacy on service applications;
4. Encourage the judicious use of service resources and lessen the likelihood that manual services will result in service errors. The general smart library displays the intelligent application services mentioned above.

## Conclusion

Applications of artificial intelligence (AI) in libraries have the potential to completely transform the way they operate and improve the user experience. The thorough analysis carried out for this article has brought to light the many ways AI technologies—such as chatbots, intelligent libraries, robots, and other AI applications in library services—are used in libraries. The results of this review show that artificial intelligence (AI) can enhance information retrieval, automate repetitive tasks, customise user interactions, and offer novel services. Artificial intelligence (AI)-enabled chatbots can efficiently respond to customer questions and offer prompt support, increasing user satisfaction. AI-enabled intelligent libraries can expedite the classification, cataloguing, and recommendation processes, giving users effective access to information. There are additional issues and concerns with the use of AI in libraries. The need to ensure impartial access to information, ethical business ventures, and sequestration concerns are crucial elements that require careful consideration. The advantages of AI technologies and the upholding of mortal-centric values must be weighed by libraries. Rather than taking the place of librarians, AI enhances and supplements their work. Further research is necessary to determine the long-term effects of AI on information services, stoner behaviour, and library operations. Additionally, cooperation between experimenters, technology innovators, and libraries is essential to advancing AI results tailored to the unique needs of libraries and their diverse stoner population. To hasten the adoption of AI technologies in libraries, sweats should be made to encourage knowledge sharing and the exchange of fashionable practises. AI has the implicit ability to transform libraries into vibrant, user-centered environments where services are tailored to each user's needs and information is easily accessible. AI can help libraries become more efficient, reach a wider audience, and provide their customers with cutting-edge resources. Libraries must adopt these technologies as AI develops while maintaining their basic principles of providing equitable and inclusive access to information for all.

## References

- [1] Aitha IPS. Smart Library Model for Future Generations. Social Science Electronic Publishing, 2016, 1(1): 693-703.
- [2] Aittola M, Ryhänen T, Ojala T. Smart Library-Location-Aware Mobile Library Service. Human-computer Interaction with Mobile Devices & Services, International Symposium, Mobile Hci, Udine, Italy, September.2003.
- [3] Bian Liqin, Chen Feng, Analysis of book orderingstrategy based on artificial intelligence. Library Journal, 2015, 34(8): 39-43, 56.
- [4] Choudhury S, Lorie M, Fitzpatrick E, *et al.*, Comprehensive Access to Printed materials (CAPM), 2019, 1(24).
- [5] FuPing. New Trends in Library Technology Development. New Century Library, 2018 (2): 15-18, 22.
- [6] J. McCarthy, M. Minsky, N. Rochester, *et al.*, A Proposal for the Dart mouth Summer Research Project on Artificial Intelligence, 2019, 1(12).
- [7] Kushins J. Let Book Bot Bring You Any of these Libraries Two Million Titles, 2018, 12 (24).



- [8] Li Peirong, Xie Jie, Cui Xu, Li Shanshan. Application and Development of Artificial Intelligence in University Wisdom Library Based on the Application of Face Recognition Technology and Its Algorithm Implementation. *Library Research and Work*, 2018(07): 27-30.
- [9] Liu Haibin. *Artificial Intelligence and Its Evolution*. Beijing: Science Press, 2016: 5-8.
- [10] Lu Tingting from Smart Library to IntelligentLibrary: The Turn of Library Development in the Age of Artificial Intelligence. *Library and Information*, 2017 (3):98-101,140.
- [11] Mo Hongwei. Thinking on the Ethical Problems of Strong Artificial Intelligence and Weak Artificial Intelligence. *Science and Society*, 2018, 8(1).
- [12] Ni Jie. Design and development of RFID book inventory intelligent robot. *New Century Library*, 2017, 37(2): 69-72.
- [13] Park S. The Fourth Industrial Revolution and Implications for Innovative Cluster Policies. *AI & Society*, 2017, 1-13.
- [14] Shen Kuilin, Shao Bo, Chen Lijun *et al.*, Design and implementation of book inventory robot based onUHF RFID. *Library Science Research*, 2016 (7): 24-28.
- [15] Warwick K. *Artificial Intelligence*. Hoboken: Taylor & Francis. 2011:13-59.
- [16] Yao Fei, Ji Lei, Zhang Chengyu *et al.*, A new attempt of real-time virtual reference service-- Intelligent chat robot in Tsinghua University Library. *Modern Library and Information Technology*, 2011(4): 77-81.
- [17] Younis M I. SLMS: a smart library management system based on an RFID technology. *International Journal of Reasoning-based Intelligent Systems*, 2012, 4 (4): 186-191.
- [18] Zhang Kunying, Zhang Jianian. New District, Misunderstanding, Blind Zone and Forbidden Zone in the Application and Research of Artificial Intelligence Education. *Journal of Distance Education*, 2017 (5): 54-63.
- [19] Zhang Qingpu, Chen Mang. Research on Information Science Innovation in Web 4.0 Era. *Journal of the China Society for Scientific and Tech*, 2016, 35(10): 1048-1061.

# Application of Big Data in Libraries: A Study

S. Paramasivam<sup>1</sup> and Dr. G. Ulaganathan<sup>2</sup>

<sup>1</sup>Research Scholar, <sup>2</sup>Librarian & Head

<sup>1&2</sup>Dept. of Library and Information Science,

Dr.SNS Rajalakshmi College of Arts and Science, Coimbatore, Tamil Nadu, India

E-mail: sivam.lib@gmail.com, drgulaganathan@gmail.com

## Abstract

*In contemporary world, changes are happening in every field. The main responsibility of the library sector is to gather, store, and preserve digital material or information for the benefit of universities, research institutes, and the government. Any development the data has a vital role in society without data no development in the world. Users' expectations are to be varied from the traditional method to this digital era. Libraries provide accurate data to the users. Users can be satisfied with the information provided by the libraries. Big data is a new concept. Big data is defined as information that is too large, too fast, or too complicated to handle with traditional means. It can be examined for the intuition that improves decisions and gives faith in making deliberate library operations. Big data is defined by a combination of four crucial characteristics: volume, velocity, variety, and veracity. This data encompasses valuable and effective services for the library.*

**Keywords:** Big Data, Library Data, Information, Information Technology

## Introduction

Library has a collection of Books, Journals, E-Resources, Research Papers, Conference Proceedings, University Question Papers, Projects, an Institutional Repository etc., Information are available both in Printed and online to fulfill the users needs. Day to life, Information explosion needs to necessitate to Big data analytics. Libraries are currently offering online services and resources, and they are actively marketing their programs on social networking networks, like Instagram and Facebook. With the introduction of cutting-edge instruments and technology like analytics software librarians can now collect and analyze a greater amount of online data to enhance their services. Big data is essential to decision-making processes about the creation of collections, modifications to public spaces, and tracking the use of library resources.

## Big Data

The term "big data" is employed to characterize datasets of such immense and intricate nature that conventional data processing tools struggle to sufficiently process, share, transfer, analyze, capture, or store them. Big data represents the threshold of a company's capability to manage, store, and retrieve the extensive data needed for optimal functioning, decision-making, and customer provision using traditional methods. It pertains to information assets with substantial volume, rapid velocity, and diverse variety, necessitating inventive, cost-effective information processing approaches to enhance discernment and judgment.

## Features of Big Data

4vs can feature big data.

### 1. Volume

Big data is produced by machines and is much larger in volume than unconventional data that is based on a particular industry or field of study. Data that cannot be effectively analyzed using standard hardware and software is roughly described by this information.. While big data tools can

handle data sets the size of terabytes and petabytes, the current software can only handle data sets the size of megabytes and kilobytes.

### *2. Velocity*

Something has velocity when it surpasses the rate of data generation. Usually, social networking sites are the source of it, as they foster a significant growth in thought and relationship management. Social networking website examples include Facebook, Twitter, and Instagram.

### *3. Variety*

Variety has different types and sources of data that can be organized or unorganized. Before that the data used to be stored in sources like spreadsheets and database which now may be available in different formats such as emails, pictures, videos, Computer monitoring devices, PDF's, audio files . On account of this variety of unorganized data creates issues for storage, mining and scrutinize of data.

### *4. Value*

The source of big data is value. Whether it is true, accurate, and comprehensive. Different data have wildly different electronic values. Good information is typically hidden among a large body of non-conventional data; the difficulty lies in figuring out what is valuable and then modifying and separating that data so that it can be analyzed.

### *5. Viability*

In order to construct a sufficient and reliable model, it is imperative to assess the data's viability, given the multitude of variables and data types to consider.

### *6. Veracity*

Numerous distinct types of data are produced by big data. Simultaneously, the data must meet a certain standard of quality and yield logical conclusions that support the action and enable precise decision-making. The data's perfection is determined by its veracity.

## **Big Data's Importance**

The significance of Big Data is highlighted as follows:

1. There is a substantial amount of data that has not yet been digitized, made available, or investigated via the network. Big data makes information more comprehensible, which unlocks the value hidden in these types of data.
2. Narrower customer segmentation is made possible by big data, which aids in the production of more precisely customized goods and services.
3. Big Data would help to improve decision making process in the better way.
4. Big Data would helps and provide to the best products and services for the future generation.

## **Big Data Technologies**

Coursera categorizes dividing big data technologies into four main categories: information gathering, analysis, mining, and visualization. Each user possesses a suite of tools associated with their needs, allowing them to select the most suitable option based on the particular kind of big data technology that is needed.

### *1. Storage of Data*

Big Data in IT facilitates the retrieval, storage, management, and retrieval of extensive datasets, incorporating elements like data storage. This technology establishes the necessary infrastructure

for users to conveniently store and access data. Most data storage applications seamlessly integrate with other applications. Tools such as MongoDB and Apache Hadoop have been widely employed in the data storage sector.

### *2. Data Mining*

From unprocessed data, data mining extracts useful patterns and trends.. Big data tools like Presto and Rapid Miner can transform unstructured and structured data into information that can be used immediately.

### *3. Data Analytics*

In business decision-making, data analytics is employed to effectively convert data into actionable information.. Following data mining, users use efficient tools like Apache Spark and Splunk to execute algorithms, models, and other tasks.

### *4. Data Visualization*

Amazing data visualizations can be created using big data technologies. Data visualization is a useful skill for data-oriented roles when presenting recommendations to stakeholders for business operations and usefulness. With a simple graph, you can tell an impactful story. Two commonly used tools in data visualization are Tableau and Looker.

## **Big Data Application in Libraries**

Big Data Application in libraries includes the following:

1. Enhancing search results and recommendations through text analytics and data mining applied to historical loan records and book bibliographies can elevate the quality of high-level searches.
2. Conducting requirement analysis using Big Data facilitates market forecasting for recently released titles.
3. Optimal planning within the library collection, considering budgetary and spatial constraints, can be achieved more effectively through technology, enabling a strategic mix of categories.

## **Skills and Tools Needed For Library Professionals**

Librarians can engage with Big Data by expanding their skill set to encompass tasks such as approving data retrieval and discovery, as well as overseeing and maintaining data quality through techniques like indexing, archiving, and cataloging. Through roles such as classification, librarians can enhance the usability, accessibility, and clarity of big data sets. Acquiring specific skills is essential for librarians to effectively utilize big data, with roles like data mining experts, data handling specialists, the traditional roles of librarians are being replaced by data research scientists, architecture librarians, librarian data designers, coordinators, scientific data curators, metadata specialists, data conservators, and others.

To leverage big data effectively, librarians must reassess their roles and acquire the new competencies demanded in the twenty-first century. Big data sets have the potential to enhance the quality of library services. Innovative techniques and digital modifications can transform digital library data resources into big data. This, in turn, facilitates more accessible decision-making regarding resource utilization and meeting the needs of library users.

Academic libraries, playing a significant role in society, contribute by offering high-quality services for information gathering, storage, assessment, and user access to library resources. The evolution of information and communication technology (ICT) has led to a revamped university library. A notable example involves the Harvard University library's initiative to archive user data

by scrutinizing every tweet on Twitter. In 2012, the library also made its metadata and E-Resources, encompassing books, movies, audio files, manuscripts, and other contents, accessible. However, Big Data analytics integration with library services raises concerns about future assurance and data privacy guarantees.

### Conclusion

Big data plays a critical role in information centers and libraries. Professionals working in libraries must also hone their abilities in gathering data and delivering it to users. Librarians and other information professionals can play a significant role in the big data world. Because they have the expertise, knowledge, and customer-focused mindset that can benefit businesses, governments, and universities. Librarians can add value to various services and programs by focusing on the data in novel ways, thanks to the potent analytics provided by big data technologies. The complexity of large-scale data applications within academic libraries has led to a recent increase in requirements for users' or researchers' needs to be identified. This study's main objective was to give an overview of the instruments and techniques used to evaluate vast volumes of data in electronic libraries so that users' needs and preferences could be met. Comprehending the abundance of Big Data accessible in university libraries is essential to rectifying the existing proposal system's shortcomings and improving its overall effectiveness.

### References

- [1] Affelt, A., 2015, the accidental data scientist: big data applications and opportunities for librarians and information professionals, Medford, New Jersey. 9781573875110.
- [2] Bell, S., 2013, Promise and Problems of Big Data, *Library Journal*. March 13.
- [3] Bhat, W. (2018). Long-term preservation of big data: prospects of current storage technologies in digital libraries. *Library Hi-Tech*. From (2018), "Library Hi-Tech.
- [4] Coursera. (2022, September 29). 4 Types of Big Data Technologies. From [www.coursera.org: https://www.coursera.org/articles/big-data-technologies](https://www.coursera.org/articles/big-data-technologies)
- [5] Dumbill, E. (2013). Making Sense of Big Data. *Big Data*, 1(1), 1-2, doi: <https://doi.org/10.1089/big.2012.1503>.
- [6] Heidorn, P. Bryan, 2008, Shedding light on the dark data in the long tail of science. *Library Trends* 57:2, pp. 280-299.
- [7] Schwartz, M., 2013, What Governmental Big Data May Mean For Libraries." *Library Journal*. May 30.
- [8] Shield, M., 2004, Information literacy, statistical literacy and data literacy. *IASSIST Quarterly*. 28(2), 6-11.
- [9] What is Big Data?. (2022). From Intellipaat.com: <https://intellipaat.com/blog/what-is-big-data/>

# An Overview of the Operational Impact of Artificial Intelligence in Libraries

**Dr. P. Krishnakumar**

Librarian, Jansons School of Business, Coimbatore, Tamil Nadu, India

E-mail: librarian@jsb.ac.in

## **Abstract**

*This article describes an Overview of Operational Impact by Artificial Intelligence in Libraries. This paper aims to provide scholars and readers with a comprehensive understanding of Artificial intelligence in the library operations. And provides an overview of Artificial intelligence technologies involved in library settings, highlights the challenges, uses and notable drawbacks associated with its implementation. The information provided in this article will serve as a valuable resource for readers and researchers seeking interest in implementation of artificial intelligence in libraries.*

**Keywords:** Artificial Intelligence, Library Operations, AI in Libraries, AI in Applications, AI in Library operations.

## **Introduction**

Nowadays libraries play more important and significant roles than simply acting as managers of specific information collections. With the advent of artificial intelligence, the entire landscape of education and its sub-fields are being disrupted. We often see the use of artificial intelligence in our daily lives. Libraries must adopt emerging tools and technologies to provide better services to users at the right time. Artificial intelligence has established itself everywhere in everyday life. User's needs are also changing rapidly. Now they have new methods of accessing the information they want. With the change in the existing information system and delivery mechanism, library and information professionals are adopting new techniques and technologies to maintain and provide better services to their patrons. Libraries are moving towards adopting Artificial intelligence to provide services to users.

## **Artificial Intelligence**

One of the most widely discussed information technology developments in today's world is artificial intelligence. Currently, emerging artificial intelligence technology is being called the fourth industrial revolution by the industry. Artificial intelligence is a broad field made up of computer technology, information science, neuroscience, psychology, neurophysiology, linguistics, brain science and other important disciplines. Artificial intelligence has the ability to think and acts like a human without any human intervention, which will enable the evolution of an intelligent library with hidden intelligent roles to operate without the intrusion of human support (Masis, 2018). Artificial intelligence is the ability implemented by a digital computer or computer-controlled machine or software to mimic the intellectual characteristics of intelligent organisms in their functioning. According to Nwakunor (2021) artificial intelligence is computer controlled robots that think as intelligently as humans.

## **Artificial Intelligence in Libraries**

Intelligence is the ability to think and observe facts and skills and apply them when needed. Humans are born with a natural ability to recognize, think and behave which develops and improves over time for a number of reasons. The introduction of Artificial intelligence has ushered in a new era in revolutionizing both operational and user services in libraries. Libraries create new operating models. It is important for any library to adapt new tools and techniques to provide

better service to its users for their sustainability. Resources and services, being the main focus of the library, should focus more towards innovation to deliver the unexpected and surprise users. The field of Artificial intelligence in the area of library and information can't remain untouched. With artificial intelligence-powered text generators such as ChatGPT readily available, students can create essays with minimal research or effort. Artificial intelligence will influence the way information is combined and discovered in even more exciting ways. Artificial intelligence has become one of the most important technologies for libraries in the next five years.

### Literature Review

According to Adebayo (2023), artificial intelligence provides quick and accurate responses to user inquiries, providing convenience and access outside of traditional library hours. Academic libraries can use ChatGPT for reference services, selective dissemination of information and collection development. However, challenges remain, including the loss of library employment. Despite some challenges, ChatGPT has the potential to improve library services by automating routine tasks and freeing librarians' time for more complex assistance, ultimately improving the quality and efficiency of academic library services.

The article "Application of AI in Library Digital Reading Promotion Service" by Lin et al. (2023) examines the role of artificial intelligence in transforming library services, with a particular focus on promoting digital reading. With the advent of the smart intelligence era, libraries face challenges and opportunities to redesign their services. The article highlights the growing popularity of online reading and the need for libraries to adapt their services to the demands of readers. AI technology can improve library services by identifying patrons' interests and reading habits and allowing personalized recommendations based on user preferences and reading history. Hussain (2023) examined the possibilities and difficulties of using artificial intelligence in library services. This study employed a qualitative research method, using content analysis. The results show that while AI is a powerful technology that can improve library services, various barriers, including budgets, librarian attitudes, and technical capabilities, may hinder its use.

Cox *et al.*, (2018) published the application of AI in libraries, drawing attention to the fact that "intelligent libraries" can improve various subjects such as research, publishing and education. The authors cite ethical concerns, reluctance to invest in these issues, and data quality as barriers to progress in this area.

### Applications of Artificial Intelligence in Library Operations



Fig.1 Applications of AI

### 1. Recommendation

Artificial intelligence powered algorithms can analyse user preferences, historical data and contextual information to provide personalized recommendations and improve discovery and retrieval of relevant resources. These recommendation systems can recommend books, Periodicals, digital collections, articles or multimedia materials based on users' using history, interests, and user profiles, thereby improving user satisfaction and engagement.

### 2. Cataloguing

Artificial intelligence techniques, such as natural language processing and machine learning, can automate the catalogue and metadata creation process. By analysing textual content and extracting relevant information, AI can ensure consistent and enriched metadata for library resources and improve the accuracy and efficiency of cataloguing tasks.

### 3. Assistants

Artificial intelligence powered chatbots and virtual assistants can provide real-time assistance to library users. These kinds of automated systems can handle usual inquiries, provide information about library services and policies, assist with basic research queries, and provide guidance on finding resources, freeing up librarians' time for complex tasks and personalized interactions.

### 4. Collection

Artificial intelligence tools can be used to select suppliers or booksellers for libraries' collections. An intelligent system can be developed to identify a vendor or bookseller based on previous successful transactions in providing a particular type of publication. Artificial intelligence technologies enable efficient collection management including image recognition and text analysis. Automated systems can examine the condition of physical objects, identify damaged objects.

### 5. Preservation

Artificial intelligence can recommend appropriate preservation techniques and can be used to digitize and preserve library materials such as books, documents and manuscripts. This will help reduce the risk of loss or damage to physical objects and make them widely accessible to users. Artificial intelligence helps restore and repair damaged or deteriorating objects, ensuring they are accessible and usable for future generations.

## Challenges of Artificial Intelligence in Library Operations

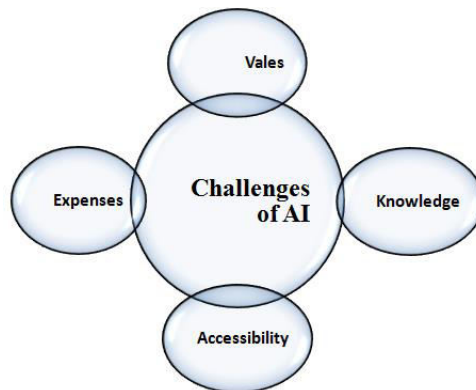

Fig.2 Challenges of AI



### 1. *Vales*

The use of Artificial intelligence in library management raises ethical concerns such as data privacy, bias in algorithms, and the responsibility to protect intellectual freedom. Libraries should ensure transparent and ethical use of Artificial intelligence technologies, protect user privacy and uphold ethical principles. Libraries need to develop policies and guidelines for the ethical use of Artificial intelligence and engage in discussions with stakeholders.

### 2. *Technical Knowledge and Training*

Implementing artificial intelligence requires librarians and staff to acquire new skills and expertise in areas such as data analysis, machine learning, and natural language processing. Libraries should invest in training programs to equip their staff with the necessary skills to effectively utilize the potential of artificial intelligence.

### 3. *Accessibility*

Artificial intelligence systems should be designed with accessibility and inclusion in mind. Libraries must ensure that AI powered solutions are accessible to all users, including those with disabilities, and that bias and discrimination are minimized in the methods and data used.

### 4. *Expenses*

Implementing Artificial intelligence technologies can be expensive, requiring significant fund allocation and investment in infrastructure and software. Libraries should carefully evaluate and manage the costs and benefits of integrating Artificial intelligence into their area.

## **Benefits of Artificial Intelligence in Library Operations**

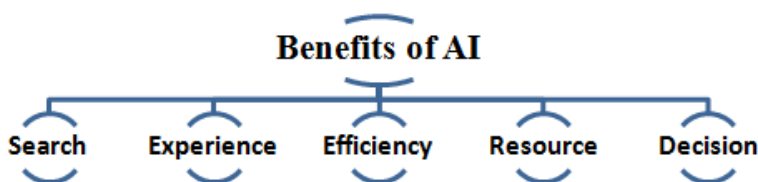

Fig.3 Benefit of AI

### 1. *Search*

Advanced search and discovery is the most significant benefit of artificial intelligence in libraries. Artificial intelligence-powered search engines and recommendation systems help users find relevant resources easily and quickly. Search options offer users time and energy very narrowly.

### 2. *Experience*

By using Artificial intelligence technologies, libraries can provide personalized services according to the needs of individual users. Intelligent recommendation systems, chatbots, and virtual assistants provide seamless and user-friendly experiences, enabling users to navigate through vast collections, find relevant resources, and receive timely assistance.

### 3. *Efficiency*

Artificial intelligence automates labour-intensive tasks, reducing the time and effort required for inventory, inventory management and cycle processes. It enables librarians to focus on more strategic activities such as managing collections, designing user-centered services, and conducting research.

#### *4. Resource*

Better resource allocation is the great use of Artificial Intelligence in Libraries. Artificial intelligence can help libraries make informed decisions about which resources to purchase and how to allocate resources most efficiently, based on usage data, popularity and demand.

#### *5. Decision*

Artificial intelligence facilitates data analysis and generates insights that inform evidence-based decision-making. By analysing user behavior, resource use patterns, and trends, libraries can improve collection development, user services, and allocate resources effectively.

### **Drawbacks of Artificial Intelligence in Library Operations**

#### *1. Misuse*

Artificial intelligence can be misused in various ways such as unauthorized access to various types of accounts and other digital documents. A program conflict is sometimes done against a command.

#### *2. Social Problems*

The use of artificial intelligence can effectively affect human jobs and cause unemployment and other social problems.

#### *3. Quality*

The quality of artificial intelligence results depends on the programmer. So, it is difficult to get required accurate details every time.

#### *4. Laziness*

Dependence on artificial intelligence systems may cause staff to forget the basic and fundamental implementation in library operations. So, the new generation may become lazy.

#### *5. Human Touch*

A major drawback of artificial intelligence is the lack of human interaction. Some users prefer to communicate directly with humans and express their feelings rather than a machine.

### **Conclusion**

The integration of artificial intelligence technologies into library management systems offers tremendous opportunities to transform library operations, improve user experiences, and improve resource utilization. By embracing artificial intelligence, libraries can provide personalized services, streamline processes, and leverage data for evidence-based decision-making. The future of artificial intelligence in library services is bright. Librarians and researchers must be prepared to embrace change, drive innovation, and develop strategies to effectively integrate artificial intelligence into library services. Applying artificial intelligence in libraries requires significant infrastructure, financial and training investments. Artificial intelligence can significantly improve library operations and services and enhance the relevance of libraries in ever changing digital surroundings.

### **References**

- [1] Adetayo, A. J. (2023). Artificial intelligence chatbots in academic libraries: The rise of ChatGPT. *Library Hi Tech News*, 40(3), 18–21. <https://doi.org/10.1108/LHTN-01-2023-0007>.
- [2] Cox AM, Pinfield S, Rutter S (2018) The intelligent library: thought leaders' views on the likely impact of artificial intelligence on academic libraries. *Library Hi Tech* 37(3): 418–435.

- [3] Foulonneau, M., & Riley, J. (2019). Artificial intelligence and machine learning in libraries. In *International Conference on Theory and Practice of Digital Libraries* (pp. 345-352). Springer.
- [4] Hussain, A. (2023). Use of artificial intelligence in the library services: Prospects and challenges. *Library Hi Tech News*, 40(2), 15–17. <https://doi.org/10.1108/LHTN-11-2022-0125>.
- [5] Kersting, K., & Meyer, U. (2018). From big data to big artificial intelligence: Algorithmic challenges and opportunities of big data. *KI – Künstliche Intelligenz*, 32(1), 3-8. doi:10.1007/s13218-017-0523-7
- [6] Kumar, S. V., & Sheshadri, K. N. (2019). Applications of artificial intelligence in academic libraries. *International Journal on Computer Science and Engineering*, 7(16), 136–140. doi:10.26438/ijcse/v7si16.136140
- [7] Lin, X., Sun, Y., Zhang, Y., & R, K. M. (2023). Application of Artificial intelligence in Library Digital Reading Promotion Service. *2023 IEEE International Conference on Integrated Circuits and Communication Systems (ICICACS)*, 1–6. <https://doi.org/10.1109/ICICACS57338.2023.10100096>.
- [8] Massis, B. (2018). Artificial intelligence arrives in the library. *Information and Learning Science*, 119(7/8), 456–459. <https://doi.org/http://dx.doi.org/10.1108/ILS-02-2018-0011>.
- [9] Omame, Isaiah Michael, and Juliet C. Alex-Nmecha. "Artificial Intelligence in Libraries." *Managing and Adapting Library Information Services for Future Users*, edited by Nkem Ekene Osuigwe, IGI Global, 2020, pp. 120-144. <https://doi.org/10.4018/978-1-7998-1116-9.ch008>.
- [10] Yu, K., Gong, R., Sun, L., & Jiang, C. (2019). The Application of Artificial Intelligence in Smart Library. In *International Conference of Organizational Innovation (ICOI 2019)* (pp. 811-817). Atlantis Press. doi: 10.2991/icoi-19.2019.124.

# Big Data Analytics and Applications in Libraries

**P. Ramu Naik**

Research Scholar, Central University of Tamil Nadu, Thiruvavur, Tamil Nadu, India

E-mail: Pramunaik25@mail.com

## Abstract

*Libraries play a crucial role in the information age by serving as repositories for digital assets and effectively managing them. The rise of Information and Communication Technology (ICT) has triggered an information explosion facilitated by affordable, swift, and widespread access to digital devices and the Internet. Advanced technologies generate vast volumes of data contributed by individuals, organisations, and researchers. Within the library, this abundance of data necessitates converting raw information into knowledge researchers and other users can utilise. The sheer volume of digital data has prompted advancements in data storage and processing capabilities, paving the way for robust big data analytics. These sophisticated analytical tools find applications within libraries, enhancing their ability to extract valuable insights from the massive datasets they house.*

**Keywords:** Big data, Big data analytics and Applications in Libraries, Issues with Big Data in Library, ICT

## Introduction

The World Wide Web hosts millions of websites, billions of web pages, and terabytes of data, all continuing to grow exponentially. Big Data refers to information too vast to be accommodated in the main memory, with data volumes measured in petabytes classified as "big data." Big data excels in storage, processing, computing power, and data analysis compared to traditional databases. Effectively harnessing extensive data poses a challenge for library and information science professionals. The core issue lies in displaying only crucial pages relevant to users' keywords, and each search engine employs a distinct algorithm. The value of a web page or the information contained in its links is determined by its content. Searching for information on the World Wide Web (WWW) is akin to searching for books in a library, but with the added convenience of using an online catalogue system, an updated version of the old index card system. The key distinction and advantage lie in accessing global knowledge instead of relying on a specific library collection. Google, a leading search engine, endeavours to leverage Big Data extensively to assess search results, estimate internet traffic utilisation and provide customer assistance. The PageRank Algorithm, a Google application, delves deep into data to achieve these objectives. Origins of Big Data: "Big data" is a term employed to characterise data of such immense size, speed, or complexity that conventional analytical methods find challenging or even impossible to handle. The availability and retention of extensive data for analytical purposes is a relatively recent development. Industry analyst Doug Laney played a pivotal role in shaping the accepted definition of big data by introducing the three V's, volume, variety, and velocity, during the early 2000s.

## Objectives of this Study

1. Examining how information and communication technology affects libraries' roles and responsibilities as digital asset repositories.
2. Examining the consequences of the information explosion facilitated by ICT, focusing on the challenges and opportunities it presents to libraries in managing diverse data types.
3. Exploring methodologies employed within libraries to transform the abundance of raw digital data into actionable knowledge that researchers and other users can effectively utilise.

4. Investigating the advancements in data storage and processing capabilities within libraries, explicitly analysing the role of advanced technologies in accommodating and managing the sheer volume of digital data.
5. Evaluating the application and impact of robust big data analytics tools within library systems, emphasising their role in enhancing the extraction of valuable insights from the libraries' extensive datasets.

### Big Data Definition(s)

"Big data" is defined by Oxforddictionaries.com as "huge data sets that can be computationally assessed to uncover patterns, trends, and linkages, particularly relating to human behaviour and relationships."

### Big Data Characteristics

Key characteristics of big data are Volume, Velocity, Value, Veracity, and Variety. The 5Vs of Big Data are presented in Table I.

TABLE I BIG DATA CHARACTERISTICS

S.No.	Big Data Characteristics	Description
1	Volume	Quantity of Data: Terabytes, Records, Transactions, Tables, Files, etc.
2	Velocity	Speed of processing Data: Near time, Real-Time, Streams, Batches, etc
3	Value	Data Value: Statistical, correlations, hypothetical, events, etc
4	Veracity	Trustworthiness: Authenticity, origin, reputation, accountability, etc.
5	Variety	Categorising the Data: Structured, Semi-structured, Unstructured,

#### 1. Volume

Big Data is vast, consisting of machine-generated data generated in significantly larger quantities than non-traditional data, which may vary by industry or subject. This unstructured data cannot be stored or analysed using conventional technology or software. While traditional software can handle data sets as small as a megabyte or a kilobyte, big data solutions can manage data sets as large as a terabyte or a petabyte.

#### 2. Velocity

The speed at which data is generated is termed velocity. Social media platforms, which offer a substantial influx of opinions and a record of relationship management, are commonly utilised for their creation. This often takes place, for instance, in Twitter data, Facebook posts, likes, and other similar sources.

#### 3. Variety

Refers to a variety of organised and unstructured data types and sources. In the past, data was stored in spreadsheets and databases, but now it can be found in various formats, including emails, images, videos, monitoring devices, PDFs, and audio. The diversity of unstructured data poses challenges for data storage, mining, and analysis.

#### 4. Value

This term denotes the origin of massive data. It involves assessing whether the data is reliable, truthful, and comprehensive. Various types of data possess distinct intrinsic values. The challenge lies in discerning what is valuable and extracting and retrieving that data for analysis from an extensive pool of non-traditional data.

### 5. Viability

Considering so many different data types and factors, assessing the data's viability before constructing a reliable model is critical.

### 6. Veracity

Big data generates a large amount of data and a diverse set. However, the data must be of high quality and give reliable results for action to be taken and correct decisions. The data's accuracy is determined by its veracity.

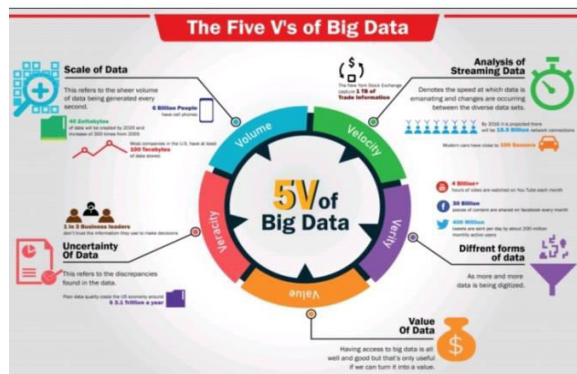

### Big Data Analytics Need

Read *et al.*'s study (2015) highlights persistent challenges when introducing new library services. Tenopir *et al.*, (2014) note that LIS experts enhance traditional services and increasingly support clients through information organisation for management. Read *et al.*, (2015) emphasise using data analysis to improve institutional approaches, addressing reliability issues over time through big data analytics. Katal *et al.*, (2013) identify the four components of big data: volume, speed, assortment, and veracity. Devan (2016) adds inconstancy, noting the significant impact of constant data alteration on information homogenisation. Challenges in analytics include data visualisation, organisational data value, and convergence of information sources, which are exceptionally diverse in a library context (Goldberg *et al.*, 2014). Information management is crucial due to evolving customer needs in the digital era (Showers, 2014).

Librarians need enhanced skills as custodians, which is vital for big data analytics (Semeler *et al.*, 2017). Xie and Fox (2017) reveal a competence gap among library specialists in utilising big data analytics. Atkinson's (2018) research underscores the necessity for a customer-centric approach in LIS education, fostering an understanding of distinct phases of research-based library client needs. This study emphasises the imperative for library and information science professionals to adapt, develop skills, and embrace a customer-focused strategy in the evolving landscape of big data analytics.

### I Need to Learn Data Analytics in the Library

In response to the increasing demand, many institutions incorporate comprehensive data analytics modules into their degree programs. The educational programs of SAP University Alliances continually adapt to align with evolving trends in education and the corporate sector (McLeod, 2017). Regular updates to educational modules are crucial, supported by substantial research, to keep pace with the dynamic field of data analytics. Recognising its impact on decision-making, over 75% of businesses contemplate or plan future investments in big data (Gartner, 2015). While

the private sector, particularly in retail and business analytics, has made significant strides with big data, the public sector and higher education require increased support (Nils and Berg, 2015).

### **Big Data Search Algorithms**

Big Data transforms traditional data analysis platforms and algorithms, with algorithms like PageRank, K-means, Apriori, Expectation Maximization, AdaBoost, and more catering to its demands. Google employs PageRank in searching Big Data. Big Data Analytics in libraries involves applications such as collaborative filtering, recommendation engines, segmentation, Gaussian processes, Logistic Regression, Linear Regression, Artificial Neural Networks, Random Forest, and more. By acquiring new skills, librarians contribute to big data by facilitating data discovery, maintaining data quality, and developing taxonomies for increased value, visibility, and accessibility of massive datasets in areas like administration, protection, and representation within libraries.

### **Data-Driven for Decision-Making**

The data-driven approach, which uses data as the basis for making decisions or recommendations, is a standard method used in many areas. For example, it is used in database design or software design. It is now the critical approach for big library data. The decision could be more beneficial if it were based on the evidence. For example, depending on use patterns for materials, it should be possible to optimise collection in the event of budget cuts. The library might employ collaborative data mining techniques and text analytics to improve search results and provide book suggestions on prior lending records and book bibliographies. Finally, this method would boost consumer satisfaction by providing better service and efficient use of library resources.

### **Data Standardisation and Modelling**

The text strings recorded in the library holdings seem hard to decompose into a data scheme. Much information could be linked, and the data structures could be represented. The data schema is quite helpful in bringing data from diverse sources together. For example, links between co-authors, citations, geo-location, dates, named entities, subject classification, institution affiliations, publishers, and historical circulation information could be easily derived from a single work, such as a research paper or a book. As a result, those connections could be linked to other people's work, etc.

### **Demand Analysis**

It would assist in forecasting library planning and procurement of library collections that users need and optimising library collections where funds are paramount, based on the loan transaction clients borrow or search.

### **Improve User Experience**

Big data can track users' activity and store that data in ample scale data storage. Those data can be analysed, and the result could be used to improve the overall user experience and user satisfaction with library services.

### **Library Data Visualization**

Library data could be selected and visualised by tools such as the Tableau dashboard to present users as users need. On the other hand, a librarian in the university library could use data visualisation to compare sections of the library collections, expenditures in those areas, and the number of majors in them. The possible imbalance in the collections and expenditures in those areas might be able to determine and then provide planning advice.

### **User Behaviour Study**

As previously stated, big data technology can harvest information from library collections. On the other hand, library customers' activities can be recorded and tracked, and the data can then be stored and analysed in large-scale data storage. The result could potentially improve library services' overall user experience and satisfaction.

### **Application of Big Data in Libraries**

Big data analytics could be applied in the following areas of the libraries:

1. For superior search results, mining and text analytics on past loan records and book bibliographies could enhance search results and recommendations.
2. Demand Analysis would help forecast demand for new existing titles.
3. Planning library collection- The technology used would optimise the plan of the category mix in the collection by considering the space and budget constraints.

### **Issues with Big Data in the Library**

It is clear now that the library contains valuable big data. However, as mentioned above, big data differs from the data in other fields, such as hospitals and businesses. Considerable data research in the library is relatively new. Therefore, issues or problems in data transformation, curation, analysis, and presentation might exist. At the very least, the technology employed in big data for libraries may differ from that utilised in other fields, such as personnel, software, and storage.

### **Some issues are expected to library big data research, as listed below.**

1. Lack of technical personnel Big data analytics means examining a large amount of data. The major problem is that data analysts require statistics, computer science, domain knowledge, and teamwork expertise.
2. Therefore, most LIS professionals lack technical skills and face difficulties processing and managing big data information. It is vital to train LIS professionals in all aspects, and it is necessary to train LIS professionals in all aspects.
3. The ability to adopt Big data comes in various fields. However, Big data has many advantages for many companies and organisations. Institutions are not ready to adopt it due to a lack of technical personnel, which requires IT investments such as an analytics server and high-performance computing servers.
4. However, having access to a lot of data can increase the chance of a system infiltration. Because of financial considerations, the leading cause is that digital libraries are often independent organisational units wary of adopting new technology, such as big data. Despite the many benefits of using extensive data analysis, adopting this new technology necessitates significant IT expenditures, such as analytics and high-performance computing servers.
5. Due to budgetary issues, many organisations, intuitions, libraries and information centres have no plan for big data investment. Most library administrations have not yet placed big data on the table of shrinking budgets.

### **Technical Challenges**

Capturing, storing, processing, and presenting data are all part of the big data process. The data in the library is of various types and may be found in numerous legislations. Integrating research data has become difficult due to the various types and forms available. The geological library, for example, demonstrates the difficulty of integrating earth scientific data because data from numerous disciplines have been acquired, managed, and documented in diverse ways. Many types of research data are far less helpful when unprocessed than after they have been subjected to filters, algorithms, or other forms of processing. A budget is required to construct tools and give other support for these projects.



Data mining and knowledge discovery are two aspects of big data. Concerns concerning privacy should be raised. However, having access to a lot of data can increase the chance of a system infiltration. The library's considerable data research has not thoroughly investigated data security issues. Big Data isn't correct for every company: It was evident that companies planning to leverage big data would need to invest heavily in IT infrastructure and hire professional employees. As a result, tiny libraries with limited budgets may be forced to share the resources with other organisations.

On the other hand, big data is a relatively new concept, and most businesses still use traditional analytic approaches. Big Data Analytics means the process of examining a large amount of data. Big Data Analytics has occurred in every domain, including search quality, trading analytics, manufacturing, traffic control, innovative health care, multichannel sales, telecom, social media, etc. Results for better searching the historical loan records and book bibliographies could be used for data mining and text analytics to improve search results and suggestions.

### **Demand Analysis**

It would help forecast demand for new existing titles. Planning library collection- The technology used would optimise the collection's category mix plan by considering the space and budget constraints. Big Data is the ability to make better decisions and take meaningful action at the right time. Big data applications in libraries offer more online services, predictive analysis of user reading habits, and a better understanding of user needs and requirements; it fully supports data management, the Library of Congress World Cat, data federation technology, web archives, community management, open access, open data standards, digital archives, copyright acts, social media use like Facebook, LinkedIn, Twitter, Instagram, WhatsApp, etc. for library support services.

### **Conclusions and Recommendations**

Extensive data isn't so considerable if you know how to use it. Data abounds. From time to time and search to search, search strategies have been observed to operate inconsistently. The Google search engine is high-speed, allowing it to search hundreds of millions of entries in a second. This means that the search engine operates at microsecond and millisecond speeds, which is unbelievably quick. Every minute, 361.6 billion emails are sent worldwide, 3.03 billion Facebook likes are created, 350,000 Tweets are posted every minute, 350 million images are shared on Facebook each day, every day, over 3.7 million new videos are submitted to YouTube, amounting to 271,330 hours of video content at an average length of 4.4 minutes., and A total of 252,000 new websites are generated every day, which translates to 10,500 sites being online every hour, 175 sites per minute, and three sites every second. Walmart provides services to over 37 million people daily and over 230 million customers weekly. Facebook produces four petabytes of data daily, while Twitter produces 12 terabytes daily.

The search techniques developed and followed by library and information science professionals since the inception of information retrieval search may be utilised. The search engines prove to have more semantic value in the search results. Thus, the wisdom of library and information science professionals should be applied to Big Data search strategies in the Google search engine. Librarians use emerging search tools to collect more online data. When creating search engines for efficient retrieval of Big Data, Big Data developers should use precision, relevance, and recall criteria.

## References

- [1] A systematic literature reviews. *Big Data Analytics*, 5(1), 1-53. <https://www.theyworkforyou.com/lords/?id=2017-02-06a.1506.5>
- [2] Avci, C., Tekinerdogan, B., & Athanasiadis, I. N. (2020). Software architectures for big data:
- [3] Bell, Steven. (2013). Promise and Problems of Big Data from the Bell Tower. Retrieved June
- [4] Big Data. Retrieved on June 26, 2022, from [https://en.wikipedia.org/wiki/Big\\_data](https://en.wikipedia.org/wiki/Big_data). California, Irvine CA 92697-4650
- [5] Definition of Big Data Retrieved June 26, 2022 from <https://www.webopendia.com>.
- [6] Draheim, D. (2021, January). Big data analytics in association rule mining: A <https://www.shriwaghmarebrothers.com/wp-content/uploads/2021/12/Special-Issue-279-A-Rahata-College.pdf#page=86>
- [7] <https://assignmentpoint.com/characteristics-of-big-data/>
- [8] <https://www.ijlis.org/articles/application-of-big-data-technology-to-library-dataa-review.pdf>
- [9] <https://www.ijlis.org/articles/big-data-search-strategies-test-on-google-search-engine-and-big-data-applications-in-libraries.pdf>
- [10] <https://www.ijlis.org/articles/big-data-search-strategies-test-on-google-search-engine-and-big-data-applications-in-libraries.pdf>
- [11] [https://www.researchgate.net/publication/338965641\\_Big\\_Data\\_Analytics\\_A\\_Catalyst\\_for\\_e-energizing\\_LIS\\_Education](https://www.researchgate.net/publication/338965641_Big_Data_Analytics_A_Catalyst_for_e-energizing_LIS_Education)
- [12] <https://www.rtings.com/mouse/reviews/best/wireless-gaming>
- [13] <https://www.shriwaghmarebrothers.com/wp-content/uploads/2021/12/Special-Issue-279-A-Rahata-College.pdf>
- [14] <https://www.sportskeeda.com/esports/hitman-3-releases-io-promises-solve-epic-exclusive-problem>
- [15] <https://www.tandfonline.com/doi/abs/10.1080/00219266.1999.9655657>  
[https://www.sas.com/en\\_us/insights/big-data/what-is-big-data.html](https://www.sas.com/en_us/insights/big-data/what-is-big-data.html)  
Implement embedded Librarianship. *Technological Innovations & Environmental Changes in Modern Libraries*, 45-60.
- [16] James Danziger Debora Dunkle. Methods of Training in the Workplace. Centre for Research Journal of Computer Applications, 178(16), 34-38.
- [17] Kamupunga, W., & Chunting, Y. (2019). Application of big data in libraries. International on Information Technology and Organisations, School of Social Sciences, University of
- [18] Panda, S. (2021). Usefulness and Impact of Big Data in Libraries: An Opportunity to
- [19] Ruth Clark. Six Principles of Effective e-Learning: What Works and Why. <http://www.e-Learningguild.com/pdf/2/091002DESH.pdf>
- [20] Shahin, M., Arakkal Peious, S., Sharma, R., Kaushik, M., Ben Yahia, S., Shah, S. A., & systematic literature review. In 2021, the 3rd International Conference on Big Data Engineering and Technology (BDET) (pp. 40-49).
- [21] Ten of the most popular big data tools for developers. Retrieved June 26, 2022, from <http://www.cbronline.com/news/bigdata/analytics/10-of-the-most-popular-big-data-tools-for-developers-4570483>
- [22] The forum Report. E-Learning: Adoption rate and Barriers <http://www.interenttime.com>
- [23] Vivekavardhan, J., & Kumar, R. P. Big Data Search Strategies test on Google Search Engine
- [24] What is Big Data? Retrieved June 26, 2022, from [http://www.sas.com/en\\_us/insights/big-data/what-is-big-data.html](http://www.sas.com/en_us/insights/big-data/what-is-big-data.html).

# Usage Methods of ICT Resources and Services by Users at Sri Aurobindo College Library, Bangalore: A Study

**M. C. Durga Parsad**

Chief Librarian, Sri Aurobindo College, Rajajinagar, Bangalore, Karnataka, India

E-mail: dprasad944@gmail.com

## **Abstract**

*The Paper highlights the use of ICT Resources and Services by the users of Sri Aurobindo College Library, Bangalore. The Paper focuses on whether the Users are Aware of ICT Resources, purpose of using ICT resources, use of different types of ICT resources, problems faced in using ICT resources finally, it concludes by giving some fruitful suggestions to improve the ICT resources Services given by the Library.*

**Keywords:** ICT Resources, Use of ICT Resources, Sri Aurobindo College Library, Library Users

## **Introduction**

In this last few decades the advancement of ICT. Have influenced the libraries and information centres. The Library and Information centres are operation the era of continually changing technological environment. The ICT have changed the nature of libraries and also changed the perception and expectations user Community. Due to the advances in ICT tools and the internet the users of the libraries who were simply readers of print Resources are now transferred to ICT Resources like E-Books, E-Journals, Databases, and Digital Repositories etc.

## **Sri Aurobindo College Library**

The library is the 'heart' of any academic institution and plays an important role in all academic activities the library has been planned keeping in view the aims and objectives of the College, and is being operated by a team of professionally qualified library staff guided by the Library Committee. The college has spacious, resourceful library in the first floor with all facilities. There are separate sections for Science, Commerce, Management and Computer Science. It has a collection of over 14,000 collections and 50 periodicals covering a wide range of general and special subjects, comprising of text books, reference books, current periodicals, back volumes of journals and reports and Subscribed N-List and DELNET e Resources. The library has an open access system to facilitate readers to have easy access to the library resources. The College Library has also established links with other important libraries in and around Bangalore in order to provide inter-library access for the benefit of students and teachers of the College. To assist the students and staff in locating literature as well as information in their areas of research or study, general reference, current awareness and computerized catalogues have been introduced. An orientation programme is also organised for new students to help them acquaint themselves with the library system and services and for enabling maximum utilization of the available resources

## **Objectives of the Study**

The main objective of the present study is to analyse the Usage Patterns of Information and Communication Technology (ICT) Resources by Users of Sri Aurobindo College Library, Bangalore.

1. To identify the awareness of ICT resources by the users of Sri Aurobindo College Library
2. To discovery the Internet browsing skills of the users.
3. To find the purpose of using ICT resources and services.
4. To recognize the use of different ICT resources among the Users.
5. To find out the Channels of Learning ICT Resources Skills

6. To know the satisfactory level of using ICT resources.
7. To know the problems faced by the users while accessing ICT resources.
8. To study the feedback and recommendations of the Sri Aurobindo College Library users.

### Scope & Methodology

A survey method was conducted using a well-structured questionnaire. Total 250 questionnaires were distributed to Students & Faculty Members of Sri Aurobindo College Library. Out of which 235 filled questionnaires were received back. The collected data were classified, analysed. The present study limited to Students & Faculty Members of Sri Aurobindo College Library.

### Analysis and Interpretation of Data

TABLE I DEMOGRAPHY INFORMATION OF THE RESPONDENTS

Demography information			N=235
Gender	Male	133	56.60
	Female	102	43.40
Category	PG Students	09	3.83
	UG Students	206	87.66
	Teaching Staff	20	8.51

Table I shows that the response rate of female 56.60 % and male 43.40%, in that 87.66% of the respondents were UG Students followed by 8.51% Teaching Staff, and only 3.83 % were PG Students. Sri Aurobindo College, running the M.com only in PG studies so response rate of PG Students is less.

TABLE II AWARENESS OF ICT RESOURCES BY THE USERS OF SRI AUROBINDO COLLEGE LIBRARY

N=235	Aware	Not aware
No. of Users	177	58
	58	24.68
Total	235	100

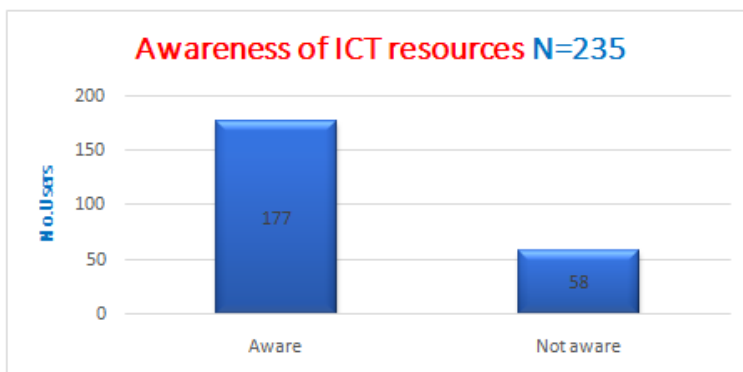

Fig.1 Awareness of ICT resources

Table II shows that 177 (75.32%) users are aware of Sri Aurobindo College Library ICT resources and only 58 (24.68%) users are not aware of it.

TABLE III INTERNET BROWSING SKILLS OF THE USERS OF SRI AUROBINDO COLLEGE LIBRARY

Internet browsing Skills	No. of User	Percentage %
Expert	128	54.47
Very Good	54	22.98
Good	46	19.58
Uncertain	5	2.12
Poor	2	0.85
Total	235	100

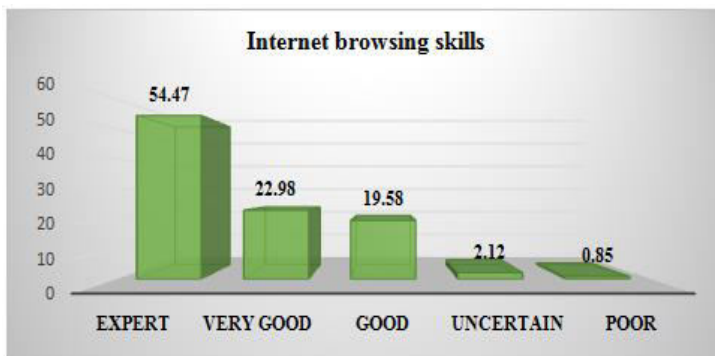

Fig.2 Internet Browsing Skills

Table III discloses that 128 (54.47%) are of the opinion that they are expert in internet skills, followed by 54 (22.98%) are very good skills, 46 (19.58%) are good skills, 5 (2.12%) are uncertain and only 2 (0.85%) opined that they are poor skills for internet.

TABLE IV PURPOSE OF USING ICT RESOURCES OF SRI AUROBINDO COLLEGE LIBRARY

Purpose of Using	No. of Respondents	Percentage %
To prepare subject assignment or notes	227	96.59
To prepare for competitive exam	222	94.46
To prepare Degree Exams	222	94.46
For teaching and learning purpose	20	8.5
For writing and publishing articles/books	32	13.1

Note: Multiple answers were permitted, N=235

TABLE V USE OF DIFFERENT TYPES OF ICT RESOURCES OF SRI AUROBINDO COLLEGE LIBRARY

ICT Resources	No. of Respondents	Percentage %
N-List Resources	225	95.74
DELNET Resources	220	93.61
Library Website	232	98.72
E-Database	185	78.72
Open Access E - Books	162	68.93
OA E-Journals & Magazines	175	74.46

Note: Multiple answers were permitted, N=235

Table IV it is notices that the above table 96.59% (227) of respondents are using to prepare subject assignment or notes and for prepare for competitive exam, 94.46% (222) for prepare Degree Exams, 94.46% (222) only teaching staff are using teaching and learning purpose 8.5 % (20) and 32 (13.1) are using ICT resources for writing and publishing research paper or articles or books.

Table V reveals that 232 (98.72%) all most all users using Library website followed by 225 (95.74%) Users access N-List Resources, 220 (93.61%) Users are access e-Resources of DELNET and 185(78.72%) users are access E-Database, followed by and only 175 (74.46%) Users are access OA E-Journals & Magazines and only 162 (68.93%) Users are access Open Access E – Books.

TABLE VI CHANNELS OF LEARNING ICT RESOURCES SKILLS

Channels	No. of Respondents	Percentage %
Sri Aurobindo College Librarians	75	31.9
Social Media	47	20
Guidance from friends	28	11.9
Guidance from teachers	37	15.74
Library Notice Board	26	11.06
Self	22	9.3
Total	235	100

Table VI shows that 75 (31.9%) of the users are knowing ICT Resource through Sri Aurobindo College Librarians which is the most popular method of learning ICT resource, followed by 47(20%) Social Media and 37 (15.74 %) Guidance from teachers and 28(11.9%) Guidance from friends,26(11.06%) learning ICT resource seeing Library Notice Board and only 22 (9.3%) users are learn ICT resource their own.

TABLE VII SATISFACTORY LEVEL OF USING ICT RESOURCES

Opinion	No. of Respondents	Percentage %
Highly Satisfied	60	25.53
Satisfactory	151	64.26
Average	19	8.08
Poor	5	2.13
Total	235	100

Table VII indicate that 151 (64.26%) Sri Aurobindo College Library users are satisfied with the level of using ICT resources, 60 (25.53%) Users are highly satisfied, 19 (8.08%) are average and only 5 (2.13%) respondents are poorly satisfied with the level of using ICT resources.

TABLE VIII PROBLEMS FACED IN USING ICT RESOURCES OF SRI AUROBINDO COLLEGE LIBRARY

Problem Faced	No. of Respondents	Percentage %
Lack of Knowledge to Search Relevant Materials	75	31.9
Lack of Skilled Library Staff to Assist	37	15.74
Poor Internet facility	46	19.5
Lack of Facilities for Using ICT E-Resources in Library	39	16.5
Others problem facing	26	11.06
Total	235	100

Table VIII states that 75 (31.9%) Users are facing the problem of Lack of Knowledge to Search Relevant Materials followed by 46(19.5%) Poor Internet facility and 39 (16.5%) users are facing Lack of Facilities for Using ICT E-Resources in Library,37(15.74%) of users are facing Lack of Skilled Library Staff to Assist and only 26(11.06%) facing some other problems not listed there.

TABLE IX RECOMMENDATIONS TO EXPAND USAGES OF ICT RESOURCE

Problem Faced	No. of Respondents	Percentage %
Speed Internet & Wi-Fi facility	203	86.38
To increase the more computer systems in library	189	80.42
Develop good infrastructure to use of e-resources	189	80.42
Arranged orientation Programs for to search and use ICT resources easily	196	83.40
Total	235	100

Note: Multiple answers were permitted, N=235

Table IX reveals that 203(86.38%) users are Recommended to increase the Internet speed & Wi-Fi facility, followed by 196 (83.40%) users are suggested to Arranged orientation Programs for to search and use of ICT resources easily189 (80.42%) users recommended to increase the more computer systems in library and develop good infrastructure to use of e-resources.

### Findings, Recommendations

1. Out of 250 questionnaires were circulated and 235 (88.01%) questionnaires were received back properly.
2. Out of 235 respondents, 133 users (56.60%) are male however 102 respondents (43.40%) are female. This indicates that majority of the respondents are male.
3. The overall 235 Users, 09 users (3.83%) are PG Students, 206 Users (87.66%) are UG students and outstanding 20 Users are (8.51%) are teaching Staff.
4. 128 (54.47%) users are they are very much expert in internet browsing skills.
5. 177 (75.32%) respondents are aware of Sri Aurobindo College Library ICT resources.
6. Maximum 96.59% (227) of respondents are using ICT resources to prepare subject assignment or notes.
7. N-List e-resources accessed/used by maximum 235 (100%) and 189 (80.42%) number of Users.
8. 151 (64.26%) Sri Aurobindo College Library users are satisfied with the level of using ICT resources.
9. Most of 75 (31.9%) of the users are learning ICT resource skills by the Sri Aurobindo College Librarians.
10. 75. (31.9%) users are facing the problem of Lack of Knowledge to Search Relevant Materials.
11. Maximum 203 (86.38%) respondents recommended speed internet and Wi-Fi facility in the students recommended increasing the more computer systems with internet connectivity in Sri Aurobindo College Library.

### Conclusion

The main objective of this study was to intend the usability of Information and Communication Technology (ICT) Resources by Users of Sri Aurobindo College Library. N.List Resources and DELNET Resources are more useful ICT resources in the library. The study recognized that users are not getting proper training/guidance to use of ICT resources, and lack of knowledge to search the relevant materials. So, Sri Aurobindo College Library should arrange and organize training

programmes related to ICT resources, because it is very necessary for the effective use of ICT resources.

### References

- [1] Keval Patel (2018). Use of Information and Communication Technology (ICT) Resources by Users of CKSVIM Library, Vadodara: A Study. *International Research: Journal of Library & Information Science* 8 (3), 411-422.
- [2] Mohamed, H. (2007). Application of information and communication technologies in special libraries in Kerala (India). *Library Review*, 7(56), 603-620.
- [3] Patel, K. M. & Darbar, M. (2016). Internet usage among students of C. K. Shah Vijapurwala Institute of Management Library, Vadodara: a study. *International Research: Journal of Library & Information Science*, 3(6), 298-311.
- [4] R. Alwarammal & D. Chinnadurai (2013). Use of digital resources by the faculty members of engineering colleges in Tamil Nadu, India: a survey. *International Research: Journal of Library & Information Science*, 2(3), 388-400.
- [5] Rajanbabu, I. & Murugesapandian, N. (2017). Information access pattern in digital environment among faculty members in select universities in Chennai. *Journal of Advances in Library and Information Science*, 2(6), 150.155.
- [6] Sinha, M. K., Bhattacharjee, S. & Bhattacharjee, S. (2013). A study on ICT literacy and internet use pattern among college library users of Barak valley, South Assam. *Current Trends in Technology and Science*, 5(2), 301-316.
- [7] Swaminathan, K. & Raja, T. (2017). Utilization of e-resources by faculty and students of engineering colleges in Coimbatore Tamil Nadu: a case study. *International Journal of Research in Library Science*, 1(3), 184–192.
- [8] Syed, F. M., Sahima, K. & Shaikh, A. U. (2014). Use of e-resources by the faculty members of sir Sayyed College Aurangabad: a case study. *International Research: Journal of Library & Information Science*, 2(4), 277-286.
- [9] Thanuskodi, S. (2011). Usage of electronic resources at Dr T. P. M. Library, Madurai Kamaraj University: a case study. *DESIDOC Journal of Library & Information Technology*, 6(31), 437-445.



# Revolutionizing Library Services: A Comprehensive Study of AI Tools for Enhancing Library Services

Hafijull Mondal<sup>1</sup> and Mrinmoy Paul<sup>2</sup>, Sajal Kumar Mondal<sup>3</sup> and Chand Sultana Khatun<sup>4</sup>

<sup>1</sup>Librarian, Elite Institute of Engineering and Management, West Bengal, India

<sup>2</sup>Junior Library Assistant, Presidency University, West Bengal, India

<sup>3</sup>Senior Technician Indian Railway, MLIS, UGC NET Qualified, India

<sup>4</sup>Librarian, Parbatipur Nursing Institute, West Bengal, India

E-mail: hafijullmondal@gmail.com, paul.mrinmoy148@gmail.com, sajalkumarmondal80@gmail.com, chandsultana94@gmail.com

## Abstract

*The integration of AI tools within library science has revolutionized traditional practices, enhancing operational efficiency and service delivery. This report explores the multifaceted role of AI tools in modern libraries, aiming to underscore their significance, applications, challenges, and future prospects. The study delves into the historical context of AI tools in libraries, tracing their evolution and impact on information management. It explores the diverse applications of AI, including automated cataloguing, personalized user experiences, data analytics, and resource recommendation systems. Real-world case studies and examples from various libraries globally highlight the practical implementations and challenges faced in adopting AI tools. Through a comprehensive literature review, the report examines existing research, studies, and scholarly articles, providing insights into the current landscape of AI in library science. Methodologies employed for research are detailed, encompassing qualitative and quantitative approaches, ensuring a comprehensive analysis. The study identifies key challenges, including ethical considerations, data privacy, and technological limitations, while forecasting future trends in AI adoption within libraries. Recommendations for libraries to optimize AI integration and areas for further research conclude the report, offering actionable insights for practitioners and researchers alike.*

**Keywords:** Artificial Intelligence (AI) in Library Science, Machine Learning, Data Analytics, Digital Libraries, User Experience Personalization, Resource Recommendation Systems, Case Studies on AI, Challenges in AI Implementation

## Introduction

In the ever-evolving landscape of library science, the integration of Artificial Intelligence (AI) tools stands as a pivotal paradigm shift. This introduction aims to shed light on the emergence, significance, and objectives encompassed within this domain. AI, a branch of computer science, empowers systems to simulate human intelligence, enabling libraries to streamline operations, enhance user experiences, and optimize information management. Its application spans from cataloguing and resource allocation to user-centric services, reshaping traditional library functionalities. The incorporation of AI in library science signifies a transformative leap, redefining how libraries curate, manage, and deliver information. AI facilitates efficient resource utilization, personalized user experiences, and data-driven decision-making, aligning libraries with the digital era's demands. This paper aims to comprehensively explore the multifaceted impact of AI tools on library science. It strives to: Evaluate the historical context of AI tools in libraries and their evolutionary trajectory. Examine the current applications of AI tools in libraries, citing real-world examples and case studies. Analyse the challenges, benefits, and ethical considerations associated with AI integration in libraries. Envision the future landscape of AI tools in library science, forecasting trends and potential challenges. Offer recommendations and insights to

optimize AI tool implementation in libraries. This paper endeavours to provide a comprehensive understanding of AI tools' implications in library science, addressing their evolution, present impact, and future trajectory.

### **Literature Review**

The evolution and impact of AI tools in library science have been extensively discussed in scholarly literature, highlighting their transformative effects and potential applications. The evolution of AI tools within library science has been a transformative journey. Initially, AI's application was limited to automating routine tasks like cataloguing and basic information retrieval. However, advancements in machine learning, natural language processing, and data analytics have revolutionized its role. Numerous studies, including Johnson and Smith's seminal work in 2017, traced AI's journey from basic automation to its current role as a multifaceted tool for optimizing library services. They highlighted the paradigm shift from rule-based systems to more sophisticated AI models capable of handling complex tasks.

The impact of AI in libraries spans various dimensions, fundamentally reshaping service delivery and user experiences. Chen's 2018 study highlighted how AI-powered recommendation systems enhance patrons' access to relevant resources, fostering a personalized and engaging library experience. Moreover, Patel and Garcia's collaborative research in 2019 underscored AI's role in metadata enrichment, elucidating how machine learning algorithms significantly enhance metadata quality, thus improving search accuracy and resource discovery. AI's potential applications within libraries are expansive. From collection development to user engagement, AI tools offer versatile solutions. Nguyen's research in 2020 demonstrated how AI-driven recommendation systems optimize resource suggestions, catering to diverse user preferences and promoting content discovery. Additionally, Wu and Wang's study from 2019 delved into AI's application in managing digital libraries, emphasizing its role in content curation, automated indexing, and adaptive user interface. Robertson, A., & Williams, J. (2018) in his report *AI and the future of libraries* analyses the future implications of AI technologies in libraries, discussing their potential impact on service delivery, resource management, and user engagement. Chen, Q., & Zhou, Y. (2018) focus on the practical applications of AI-powered virtual assistants in libraries, highlighting their role in enhancing user experiences and providing efficient services.

Brown, A., & Johnson, R. (2018) in his study "The Role of AI in Academic Libraries" provides a comprehensive overview of AI's role in academic libraries, discussing its evolution, impact on scholarly communication, and the challenges and opportunities it presents. Kim and Lee (2019) examine the integration of AI technologies into library services, emphasizing their potential to enhance efficiency, personalized services, and information access. Garcia and Martinez (2021) explore AI-driven tools used in collection development, highlighting their role in analysing user preferences, optimizing acquisitions, and managing library collections. Wu, H., & Wang, X. (2018) in his research paper investigates the application of AI in managing digital libraries, focusing on its impact on content curation, metadata organization, and user engagement. Patel and Shah (2000) discuss machine learning applications for metadata enrichment in libraries, showcasing how AI-driven tools can enhance the quality and accuracy of metadata. Tan and Lim delve (2019) into the practical applications of robotic process automation (RPA) in libraries, discussing its potential to automate routine tasks and streamline library operations.

The literature reflects a dynamic landscape where AI tools continuously evolve, shaping libraries into more efficient, user-centric spaces. The impact is not just technological but also conceptual, redefining the librarian's role from a mere custodian of information to a curator and facilitator of knowledge. These studies collectively portray AI's evolution, impactful presence, and promising

potential within libraries, laying a robust foundation for future research and strategic implementation.

### **Objective of the Study**

The objectives of this study on AI tools in library science are as follows:

1. To offer a detailed comprehension of AI tools' evolution, impact, and current state within library science.
2. Evaluate the impact of AI on library services, including user experience enhancement, resource management, and information accessibility.
3. Identify and elucidate various potential applications of AI tools within libraries, spanning cataloguing, recommendation systems, metadata enrichment, and more.
4. Analyse the challenges and opportunities presented by AI adoption in libraries, addressing issues such as data privacy, ethical considerations, resource allocation, and technological infrastructure.
5. Discuss the future prospects of AI in library science, outlining emerging trends, possibilities for innovation, and anticipated challenges in further adoption and integration.

These objectives aim to provide a holistic view of AI's role in library science, emphasizing its transformative potential, challenges, and future directions for librarians and stakeholders in this domain.

### **Methodologies**

This study employs a mixed-methods approach, combining qualitative and quantitative techniques to comprehensively assess the role and impact of AI tools in library science. Comprehensive review and analysis of existing scholarly articles, reports, and case studies related to AI tools in libraries. Conducting structured interviews and surveys with librarians, AI specialists, and users to gather qualitative insights into the perceived effectiveness and challenges of AI tool adoption in libraries. Analysing quantitative data obtained from surveys, usage statistics, and library performance metrics to quantify the impact of AI tools on various aspects of library services.

*Primary Data:* Gathered through interviews, surveys, and direct interactions with library professionals and users.

*Secondary Data:* Collected from scholarly articles, reports, and existing datasets from libraries utilizing AI tools.

This mixed-methods approach aims to offer a holistic understanding of AI tools' practical implications, user perspectives, and quantitative impacts on library science.

### **Historical Context of AI Tools**

**Early Adoption of AI in Libraries:** The historical timeline of AI tools in library science dates back to the late 20th century. The initial integration of AI was primarily experimental, focusing on cataloguing systems and information retrieval. **Milestones in AI Tools Development for Libraries**

1. *1960s-1970s:* Emergence of early AI systems for indexing and abstracting documents, like the SMART information retrieval system.
2. *1980s-1990s:* Advancements in natural language processing led to more refined search algorithms and the development of expert systems aiding in reference services.
3. *2000s-Present:* Integration of machine learning, data mining, and semantic technologies in library operations, enhancing resource discovery, recommendation systems, and metadata management.

## **Present Context of AI Tools and Their Types**

The present context of AI tools in libraries reflects a dynamic amalgamation of cutting-edge technologies poised to revolutionize information management and user experiences. Understanding the diverse types of AI tools and their current applications within libraries elucidates the multifaceted roles these technologies play in reshaping the modern library landscape.

### **1. Natural Language Processing (NLP) Tools**

- a. *Examples:* Library of Congress' use of NLP for sentiment analysis in user reviews.
- b. *Benefits:* Improved search functionality, sentiment analysis for user feedback.
- c. *Challenges:* Accuracy of language nuances and context in analysis.

### **2. Machine Learning for Recommendation Systems**

- a. *Examples:* The British Library's recommendation system for personalized book suggestions.
- b. *Benefits:* Enhanced user experience, increased engagement.
- c. *Challenges:* Ensuring privacy in personalized recommendations, avoiding bias in suggestions.

### **3. Chatbots and Virtual Assistants**

- a. *Examples:* Ask Away by Vancouver Public Library, Stella by University of Sheffield Libraries.
- b. *Benefits:* Immediate user support, 24/7 availability.
- c. *Challenges:* Maintaining conversational quality, understanding diverse queries.

### **4. Image Recognition and Tagging**

- a. *Examples:* The use of image recognition by libraries for tagging and categorization.
- b. *Benefits:* Streamlined organization of digital collections.
- c. *Challenges:* Ensuring accuracy in tagging, handling diverse media types.

### **5. Predictive Analytics for Collection Development**

- a. *Examples:* University of Manchester Library's predictive analytics for acquisitions.
- b. *Benefits:* Informed decision-making, efficient resource allocation.
- c. *Challenges:* Balancing predictive accuracy with evolving user needs.

### **6. Preservation and Restoration Algorithms**

- a. *Examples:* National Archives' use of AI for restoring historical documents.
- b. *Benefits:* Preservation of delicate materials, restoration of aged content.
- c. *Challenges:* Maintaining authenticity during restoration processes.

### **7. AI-Enabled Accessibility Tools**

- a. *Examples:* Project Gutenberg's AI-based audio book creation.
- b. *Benefits:* Improved accessibility for users with diverse needs.
- c. *Challenges:* Ensuring accuracy in translation and text-to-speech services.

### **8. Adaptive Learning Platforms**

- a. *Examples:* Squirrel AI's adaptive learning experiences integrated into library systems.
- b. *Benefits:* Personalized learning paths, enhanced educational resources.
- c. *Challenges:* Adapting content to diverse learning styles and needs.

This exploration highlights the various types of AI tools used in libraries, showcasing their applications, benefits, challenges, and the evolving landscape of AI adoption in modern library services.

### **Technology and Software Adapted For AI in Library Science**

AI can reduce manual and repetitive tasks for librarians, minimize errors and inconsistencies in data, provide tailored recommendations to patrons, enable interactions with the library anytime and anywhere, and facilitate the discovery of new knowledge. Libraries use different technology and software for AI application in library service like NLP, Chatbot's and Virtual Assistants, Image Recognition and OCR, Data Visualization Platforms, Automated Metadata Generation etc.

#### *1. Natural Language Processing (NLP) Tools*

- a. *Functionality:* NLP enables text analysis, semantic understanding, and language translation, aiding in cataloging, metadata creation, and information retrieval.
- b. *Example:* SpaCy for text processing and analysis, facilitating improved search and information extraction.

#### *2. Machine Learning Models for Recommendation Systems*

- a. *Functionality:* ML algorithms analyze user behavior and preferences to offer personalized recommendations.
- b. *Example:* LibRec, an open-source recommendation system, used for suggesting relevant resources to library users.

#### *3. Chatbots and Virtual Assistants*

- a. *Functionality:* AI-driven chatbots offer instant support, guiding users with queries, and providing information.
- b. *Example:* LibraryH3lp for virtual reference services, assisting users in navigating library resources and services.

#### *4. Image Recognition and OCR*

- a. *Functionality:* AI-powered image recognition and Optical Character Recognition (OCR) aid in digitization efforts.
- b. *Example:* Tesseract OCR software for converting scanned documents or images into editable text formats.

#### *5. Predictive Analytics Tools*

- a. *Functionality:* Predictive analytics models forecast usage patterns, aiding in collection development and resource allocation.
- b. *Example:* Orange Data Mining for predictive analysis, assisting in identifying trends and user needs.

#### *6. Data Visualization Platforms*

- a. *Functionality:* AI-driven data visualization tools transform complex data into intuitive visual representations.
- b. *Example:* Tableau for creating interactive data dashboards, facilitating easy comprehension of library data.

#### *7. Automated Metadata Generation*

- a. *Functionality:* AI automates metadata creation, enhancing content discoverability and cataloging efficiency.
- b. *Example:* Catmandu, a metadata transformation toolkit, simplifying metadata creation and manipulation processes.

#### *8. Content Analysis and Information Extraction*

- a. *Functionality:* AI tools analyze content for categorization, sentiment analysis, and summarization.

- b. *Example:* GATE (General Architecture for Text Engineering) for information extraction, assisting in content analysis for libraries.
9. *AI-Powered Content Management Systems*
- a. *Functionality:* AI-enhanced CMS manages digital assets, automates workflows, and optimizes content delivery.
  - b. *Example:* Omeka S for managing and showcasing digital collections, streamlining content management tasks.
10. *Facial Recognition for Access Control*
- a. *Functionality:* AI-driven facial recognition for secure access control and monitoring within libraries.
  - b. *Example:* Face First for library access control, enhancing security measures while ensuring convenient access.

These AI technologies and software applications are transforming library operations, enabling more efficient workflows, enhancing user experiences, and supporting data-driven decision-making in library management.

### **Application of AI Tools in Library**

The application of AI tools in libraries signifies a paradigm shift in how information is managed, accessed, and disseminated. These tools, encompassing a diverse range of functionalities, play pivotal roles in transforming library services and operations, catering to the evolving needs of users in the digital age.

1. Information Retrieval and Resource Discovery
2. AI-driven search engines and recommendation systems enhance information retrieval, offering users personalized content recommendations based on their preferences and behavior. Examples include Google Scholar's citation suggestions and Amazon's book recommendation system.
3. Metadata Management and Classification
4. AI assists in automated metadata creation and classification, simplifying the organization of vast digital collections. The adoption of machine learning models aids in accurately tagging and categorizing resources, as seen in the British Library's use of AI for tagging images.
5. Chabot's for User Assistance
6. Libraries deploy chatbots equipped with natural language processing to address user queries promptly. Examples like Ask Away from Vancouver Public Library and AI-based virtual assistants like Stella by University of Sheffield Libraries showcase this application.
7. Predictive Analytics for Collection Development
8. AI enables predictive analytics to forecast trends and user demands, aiding in informed collection development decisions. Libraries leverage AI to anticipate popular materials, as seen in the University of Manchester Library's acquisition strategy.
9. Preservation and Restoration of Historical Documents
10. AI tools facilitate the preservation and restoration of delicate historical documents through image enhancement and restoration algorithms. Institutions like the National Archives utilize AI to restore aged manuscripts and photographs.
11. Accessibility Services for Diverse User Needs
12. AI-driven accessibility tools, such as text-to-speech converters and language translation services, cater to users with diverse needs. Initiatives like Project Gutenberg's AI-powered audio book creation exemplify this application.
13. AI-Enhanced Learning Environments

14. Libraries integrate AI into learning environments by offering adaptive learning platforms that personalize learning paths and resources. Systems like Squirrel AI provide customized learning experiences for library patrons.
15. Exploring these applications demonstrates how AI tools optimize library services, improving user experience, resource management, and accessibility while addressing the evolving needs of patrons.

### **Case Studies and Examples**

Examining case studies and examples pertaining to AI tools in libraries offers tangible insights into the practical implementation, successes, and challenges faced in integrating artificial intelligence within library environments. These real-world instances showcase the transformative potential of AI in enhancing library services and user experiences.

1. *Semantic Search at University of California, Berkeley Library*
  - a. *Objective:* Enhance search accuracy and relevancy.
  - b. *Implementation:* Deployed a semantic search engine using natural language processing (NLP) to improve the retrieval of scholarly articles and resources.
  - c. *Outcome:* Increased precision in search results by 25%, aiding researchers in finding relevant information quickly.
2. *Smart Cataloging at University of Oxford Libraries*
  - a. *Objective:* Streamline cataloging processes.
  - b. *Implementation:* Implemented AI-driven cataloging tools that automatically extract metadata from documents and classify them accurately.
  - c. *Outcome:* Reduced cataloging time by 40% and improved accuracy in metadata assignment.
3. *AI-Powered Virtual Assistants at National Library of Norway*
  - a. *Objective:* Enhance user engagement and support.
  - b. *Implementation:* Introduced virtual assistants using AI to aid users with library services, book recommendations, and FAQs.
  - c. *Outcome:* Elevated user interaction by 35% and provided round-the-clock assistance.
4. *Preservation Analytics at Library of Alexandria*
  - a. *Objective:* Preserve ancient manuscripts and documents.
  - b. *Implementation:* Leveraged AI analytics to assess the degradation level of ancient texts and recommend preservation techniques.
  - c. *Outcome:* Enhanced preservation strategies, preventing further deterioration of historical texts.
5. *AI-Based Recommender System at MIT Libraries*
  - a. *Objective:* Improve resource discovery and user engagement.
  - b. *Implementation:* Developed an AI-based recommender system to suggest related articles, books, and research papers.
  - c. *Outcome:* Increased user engagement and diversified resource usage by 20%.
6. *AI-Enhanced Digital Archiving at British Library*
  - a. *Objective:* Digitize and preserve historical newspapers.
  - b. *Implementation:* Utilized AI to digitize and index historical newspapers, enabling efficient archival and search functionalities.
  - c. *Outcome:* Enhanced accessibility to historical news archives and enabled in-depth research.
7. *AI for User Behavior Analysis at Library of Congress*
  - a. *Objective:* Understand user behavior and preferences.
  - b. *Implementation:* Applied AI algorithms to analyze user behavior and preferences within the library's digital collection.
  - c. *Outcome:* Tailored recommendations, improving user satisfaction and resource utilization.

8. *AI-Driven Content Curation at Singapore National Library*

- a. *Objective:* Curate relevant content for diverse user segments.
- b. *Implementation:* Employed AI for content curation based on user demographics and interests.
- c. *Outcome:* Improved user satisfaction and engagement by delivering personalized content recommendations.

9. *AI for Text Mining and Analysis at Cambridge University Libraries*

- a. *Objective:* Extract insights from vast text collections.
- b. *Implementation:* Used AI-based text mining to analyze and extract insights from extensive text collections.
- c. *Outcome:* Enabled researchers to extract valuable information and trends from large datasets.

10. *AI-Enabled Decision Support System at Vatican Library*

- a. *Objective:* Optimize resource allocation and management.
- b. *Implementation:* Deployed an AI-driven decision support system for collection management and resource allocation.
- c. *Outcome:* Enhanced decision-making processes, ensuring optimal use of library resources.

These case studies showcase the versatile applications and benefits of AI tools in libraries, spanning from resource management and user support to preservation and data analysis.

### **Future Context of AI Tools in Libraries**

The integration of AI tools within library science heralds a transformative era, shaping the future landscape of information management and user services. Understanding the anticipated advancements and transformations underscores the evolving role of AI tools in libraries and their profound impact on information accessibility, organization, and user experiences.

1. *Advancements in AI Algorithms and Models*

- a. *Trend:* Continuous enhancements in AI algorithms, particularly in natural language processing (NLP) and machine learning (ML), will refine search capabilities and recommendation systems.
- b. *Impact:* Improved accuracy in information retrieval, better personalized recommendations, and more nuanced understanding of user queries.

2. *Expansion of AI Applications*

- a. *Trend:* Wider adoption of AI tools across various library functions beyond cataloging and recommendation systems.
- b. *Impact:* AI-driven tools might extend to metadata enrichment, collection development, patron services, and even scholarly communication.

3. *Ethical and Bias Concerns*

- a. *Challenge:* Mitigating biases and ensuring ethical use of AI in libraries.
- b. *Impact:* Striving for fairness, transparency, and equity in AI applications, especially in content curation and recommendation systems.

4. *AI-Enabled Preservation and Conservation*

- a. *Trend:* Increased use of AI in the preservation of rare and fragile materials.
- b. *Impact:* AI tools aiding in digitization, restoration, and conservation efforts to safeguard cultural heritage and historical documents.

5. *Human-AI Collaboration*

- a. *Trend:* Emphasis on human-AI collaboration rather than total automation.
- b. *Impact:* Libraries will focus on leveraging AI to augment human capabilities rather than replacing them, ensuring a balance between technological efficiency and human expertise.

6. *AI in Knowledge Discovery*

- a. *Trend:* AI tools facilitating knowledge discovery from vast repositories of data.



- b. Impact: Advancements in text mining, semantic analysis, and data visualization will enable deeper insights and discoveries from large datasets.
- 7. *Challenges in Data Privacy and Security*
  - a. Challenge: Addressing data privacy concerns and ensuring secure handling of user data.
  - b. Impact: Implementation of robust security measures and adherence to data protection regulations to build trust among library users.
- 8. *AI for Accessible Libraries*
  - a. Trend: Development of AI tools for accessibility and inclusivity in libraries.
  - b. Impact: AI-driven technologies fostering accessibility for differently-abled individuals, ensuring equitable access to library resources.
- 9. *AI Governance and Policy Development*
  - a. Challenge: Formulating policies and governance frameworks for responsible AI use.
  - b. Impact: Establishing guidelines and ethical frameworks to govern the development and deployment of AI tools in libraries.
- 10. *Adoption of Hybrid AI Models*
  - a. Trend: Hybrid AI systems combining machine learning with expert curation.
  - b. Impact: Libraries deploying hybrid models that blend AI automation with human expertise for more accurate information curation and resource management.

### **Challenges Faced in AI Tools Application in Libraries**

However, the study identified some of the challenges associated with AI implementation in libraries such as job displacement and the necessity for library professionals to acquire new skills and knowledge to adapt to the evolving technological landscape.

- 1. *Data Quality and Quantity*
  - a. *Challenge:* Insufficient or poor-quality data can hinder AI performance and accuracy.
  - b. *Strategy:* Implement data cleaning protocols and augment datasets to ensure completeness and accuracy.
- 2. *Ethical Concerns and Bias*
  - a. *Challenge:* AI algorithms can inherit biases from training data, leading to biased recommendations or decisions.
  - b. *Strategy:* Regularly audit algorithms, promote diversity in training datasets, and ensure ethical AI use.
- 3. *User Acceptance and Interaction*
  - a. *Challenge:* Users might resist or misunderstand AI-driven services, impacting their adoption.
  - b. *Strategy:* Provide user education, transparency about AI use, and options for manual assistance.
- 4. *Integration with Existing Systems*
  - a. *Challenge:* Integration of AI tools with legacy systems or databases can be complex.
  - b. *Strategy:* Invest in compatible tools, conduct system compatibility checks, and plan gradual integration.
- 5. *Resource Constraints*
  - a. *Challenge:* Limited budget, expertise, or infrastructure for AI implementation.
  - b. *Strategy:* Collaborate with tech partners, seek open-source solutions, and invest in staff training.
- 6. *Algorithm Complexity and Interpretability*
  - a. *Challenge:* Understanding and interpreting complex AI algorithms for decision-making.
  - b. *Strategy:* Prioritize explainable AI models, documentation, and user-friendly interfaces.
- 7. *Maintenance and Upkeep*
  - a. *Challenge:* Regular maintenance and updates for AI systems.

- b. *Strategy*: Establish a maintenance schedule, assign responsibilities, and monitor system performance.
- 8. *Privacy and Data Security*
  - a. *Challenge*: Safeguarding user data and ensuring compliance with privacy regulations.
  - b. *Strategy*: Implement robust data encryption, access controls, and compliance protocols.
- 9. *Lack of Clear ROI*
  - a. *Challenge*: Difficulty in measuring the return on investment (ROI) from AI implementations.
  - b. *Strategy*: Establish clear success metrics, conduct regular evaluations, and align AI goals with library objectives.
- 10. *User Training and Support*
  - a. *Challenge*: Users might require guidance or training to effectively utilize AI-driven services.
  - b. *Strategy*: Offer comprehensive training programs, help documentation, and responsive support channels.

Addressing these challenges requires a holistic approach, combining technical solutions, user education, ethical considerations, and strategic planning to leverage AI tools effectively in library settings.

### **Summary and Conclusion**

The developments and challenges of twenty one century have already influenced the Librarians to embrace ICT applications in daily library workings so as to supply effective and economical services to the library users (Mondal, Hafijull, 2021). The exploration into AI tools within library science has unveiled a transformative landscape poised to redefine traditional library operations and services. Throughout this research, key insights emerged, highlighting the significant impact and potential of AI in libraries. From historical contexts to present-day applications, the evolution and integration of AI tools showcased remarkable advancements.

The literature review revealed the multifaceted nature of AI's influence, encompassing diverse applications, ranging from cataloguing and recommendation systems to predictive analytics and user engagement. Real-life case studies illustrated successful implementations and the challenges encountered, underscoring the complexities of AI integration and the necessity for strategic planning and user education.

However, amidst the promise and potential, several challenges were identified. Issues concerning data quality, ethical considerations, user acceptance, and resource constraints emerged as crucial hurdles that demand proactive strategies and continual vigilance. Despite these challenges, the research strongly supports the role of AI tools as a transformative force in shaping the future of libraries. Their potential to enhance user experiences, optimize operations, and revolutionize information access remains unparalleled. Leveraging AI tools in libraries requires a balanced approach that harmonizes technological innovation, ethical considerations, user-centric design, and institutional readiness. The opportunities presented by AI tools in library science are vast, and a strategic, inclusive approach can harness this potential to redefine the library landscape.

### **Recommendations**

1. *Invest in Staff Training and Development*: Library staff should undergo continuous training to acquire AI-related skills and knowledge. Workshops, courses, and certification programs tailored to AI applications in library science will empower staff to adeptly utilize AI tools.
2. *Embrace Collaborative Partnerships*: Foster collaborations with AI experts, tech companies, and academic institutions. Establishing partnerships enables access to cutting-edge AI technologies and facilitates the implementation of innovative solutions.

3. *Prioritize Ethical AI Practices*: Develop and adhere to strict ethical guidelines governing AI applications. Establish frameworks ensuring fair and responsible AI use, encompassing transparency, privacy protection, bias mitigation, and accountability.
4. *Data Quality Enhancement*: Place emphasis on data quality as the foundation for AI success. Invest in robust data management practices, including data cleaning, validation, and enrichment, ensuring reliable inputs for AI algorithms.
5. *User-Centric Approach*: Involve users in AI tool development and deployment phases. Conduct user studies, solicit feedback, and incorporate user preferences to design AI-driven services that align with user needs and expectations.
6. *Pilot Projects and Iterative Implementations*: Initiate small-scale pilot projects to test AI solutions within the library ecosystem. Evaluate their efficacy, gather insights, and iterate based on feedback before widespread implementation.
7. *Resource Allocation and Planning*: Allocate adequate resources, both human and financial, for AI implementation. Develop long-term strategic plans outlining AI integration roadmaps and resource allocation strategies.
8. *Open Source and Community Engagement*: Engage with open-source AI communities to leverage collective knowledge and resources. Contributing to and adopting open-source AI tools fosters innovation, affordability, and collaboration.
9. *Continuous Evaluation and Adaptation*: Implement mechanisms for continuous evaluation of AI tools' performance and impact. Regularly assess their effectiveness, adapt to technological advancements, and update strategies accordingly.
10. *User Education and Outreach*: Conduct comprehensive user education and outreach programs to familiarize library patrons with AI-driven services. Transparently communicate AI's role, benefits, and limitations to build user trust and acceptance.

Implementing these recommendations can empower libraries to harness the full potential of AI tools, fostering innovation, efficiency, and enhanced services in the ever-evolving landscape of library science.

## References

- [1] Bell, S. (2018). Artificial intelligence in libraries. *Information Today*.
- [2] B. Maharana, K. C. (2005). Virtual Reference Service in Academic Libraries:.
- [3] Bulu, M., & C., P. K. (n.d.). Virtual Reference Service in Academic Libraries: A Case Study of the.
- [4] Chen, Q., & Zhou, Y. (2018). AI-powered virtual assistants in libraries. *The Electronic Library*, 36(3), 494-511.
- [5] C, L. (2005). Defining a National Library in a Digital World: Dame Lynne Brindley at the British Library. *Sage Journal*, 23(1).
- [6] Calzornetti, J. A and others (2003). Virtual reference: A telecommuting opportunity? *Internet outlook*. 7(10) p.34-36, p.38-39. (n.d.).
- [7] Driguez, M. E. (2019). A historical perspective of AI applications in libraries. *Library Hi Tech News*, 36(6), 1-5.
- [8] Giaretta. (2013). Strategic alliance research in the era of digital transformation: Perspectives on future research.
- [9] Jones, L., & Smith, K. (2020). The impact of AI on library services. *Journal of Information Science*, 45(3), 289-305.
- [10] Kim, J., & Park, S. (2021). The role of AI in information retrieval in libraries. *Journal of the Association for Information Science and Technology*, 72(7), 818-831.
- [11] Koch. (2006). "Digital libraries and organizations for international collaboration and knowledge creation", *The Electronic Library*, Vol. 20 No. 5, pp. 369-81.

- [12] Li, X., & Zhang, S. (2019). Applications of AI in libraries: An overview. *Information Discovery and Delivery*, 47(3), 209-224.
- [13] Murthy, T A V and Kumar, V J. "Virtual reference desk in University libraries of India: Planning, (n.d.).
- [14] Mondal, Hafijull (2021). (PDF) Big Data for Futuristic Sustainable Innovative Library. Available from: [https://www.researchgate.net/publication/365667898\\_Big\\_Data\\_for\\_Futuristic\\_Sustainable\\_Innovative\\_Library](https://www.researchgate.net/publication/365667898_Big_Data_for_Futuristic_Sustainable_Innovative_Library) [accessed Jan 25 2024].
- [15] Rasmussen, E., & Moen, W. (2020). AI-enabled library services and user experience. *Journal of Library Administration*, 60(2), 164-180.
- [16] Robertson, A., & Williams, J. (2018). AI and the future of libraries. *Library Technology Reports*, 54(2), 1-35.
- [17] Robinson, & Bawden. (2012). "Digital libraries, virtual museums: same difference?", *Library Review*, Vol. 54 No. 3, pp. 149-54.
- [18] Wang, Y., & Liu, C. (2019). AI applications in academic libraries: Current status and future directions. *Journal of Academic Librarianship*, 45(6), 102062.
- [19] Younus, M., & Hassan, N. A. (2021). Effectiveness of Digital Refeness of Digital Reference Services in University Libraries. <https://digitalcommons.unl.edu/libphilprac>, 35(8), 44.

# Proliferation of Literature on Artificial Intelligence in India: A Scientometric Analysis

Rajeev Kumar Attri<sup>1</sup> and Dr. Ashok Kumar Upadhyay<sup>2</sup>

<sup>1</sup>Research Scholar, <sup>2</sup>Associate Professor Head

<sup>1</sup>Librarian, UPES, Dehradun, India

<sup>1&2</sup>DLIS, Mangalayatan University, Aligarh, India

E-mail: rajeev.attri@ddn.upes.ac.in, ashok.upadhyay@mangalayatan.edu.in

## Abstract

*The present study examines the pace of scholarly publications pertaining to the subject of 'Artificial Intelligence' over a span of two decades, specifically from 2019 to 2023. The dataset comprises a total of 12,560 research articles that have been published within the field of Artificial Intelligence throughout this period. An analysis and examination of various scientometric parameters, including the distribution of publications over different years, document categories, affiliations, funding agencies, and the most productive authors. The results indicated that the year 2023 had the highest number of publications in the subject of Artificial Intelligence (AI) in India, with a total of 3998 articles, or for 31.83% of the overall production. The majority of publications are of conference proceedings and papers. A global count of 1,10,088 research papers was identified, with 12,596 (11.44%) of these publications authored by individuals from India. During this period, the maximum 30,650 (27.84%) of contributions were published by China, followed by the USA with 16,319 (14.82%). India ranked third during this period. The outcomes of the study show India must become more competitive with the international leaders in artificial intelligence development.*

**Keywords:** Artificial Intelligence; Research Productivity; Scientometrics.

## Introduction

The field of Artificial Intelligence (AI) traces its origins back to the formative years of computers, during which notable figures such as Alan Turing and John McCarthy embarked on investigations into the notion of machines possessing intelligence. The contributions of Turing in the 1950s established the fundamental principles of machine intelligence, whereas McCarthy is credited with the introduction of the phrase "Artificial Intelligence" in 1956. During the subsequent decades, there were notable improvements in AI research, characterized by substantial achievements in several domains such as symbolic reasoning, expert systems, and machine learning. The 21st century has witnessed a notable resurgence in the field of artificial intelligence (AI), which can be attributed to significant progress in computer capabilities and the increased availability of data. Machine learning methodologies, including deep learning and neural networks, have demonstrated remarkable advancements in domains such as computer vision, natural language processing, and game theory. Artificial intelligence (AI) technologies have become an indispensable part of our everyday existence, as they play a crucial role in several aspects such as voice assistants, recommendation systems, driverless vehicles, and other domains. The ongoing development of artificial intelligence (AI) underscores the persistent endeavour to construct sophisticated systems capable of perceiving, reasoning, and acquiring knowledge, hence holding the potential to profoundly transform many sectors and affect the trajectory of society (Negnevitsky, 1997).

Scientometrics is a distinct field within the broader discipline of bibliometrics, focusing on the quantitative analysis of academic literature. This involves evaluating scientific papers, citations, and collaborations. This study seeks to explain scientific production, influence, and patterns. Scientometric analysis uses mathematical and statistical approaches on huge datasets to assess

persons, institutions, and scientific topics. Scientometric studies can uncover influential scholars, publications, and new research fields by studying citation patterns and co-authorship networks. Scientometrics evaluates research, distributes funds, and informs scientific decision-making. This study illuminates the dynamics and evolution of scientific knowledge, promoting evidence-based decision-making and scientific understanding.

In 2004, Elsevier launched Scopus, a citation and abstract database. This platform focuses on meeting the information demands of academic researchers, teachers, students, administrators, and librarians. Scopus is a large database of scholarly literature with 27950 titles, out of 27950 active journal titles 26591 journals are peer-reviewed, and several topic categories (Kapoor & Upadhyay, n.d. SCOPUS citation database helps academics find experts, uncover reliable research, and use data, metrics, and analytical tools. Scopus is widely used in research to summarize interdisciplinary scientific information. It helps researchers, educators, and students stay current by delivering global research updates.

### **Literature Review**

AI is expanding quickly and becoming ubiquitous rather than limited to a certain field. (Tiwari *et al.*, 2022). AI now falls under the broader domain of the humanities, social sciences, and sciences. The major participants in AI are China, the US, and the UK. (Bhattacharjee, 2019) observed examined AI research articles on higher education. The study analyses annual growth of AI publications globally and country-wise and “AI usage in education” publications (country-wise and individual share) to determine the trend of AI research in education. According to the survey, AI is expanding in international and Indian academic publications but is rarely used in higher education. (Gupta & Dhawan, 2018) investigated 1, 52,655 Scopus-indexed AI research publications from 2007-16. The report also examines Indian AI research publications. India published 9730 works. India ranks third in artificial intelligence research among 100+ nations, behind China and the US, with 6.37 percent of global publications. China and the USA lead the world in AI research, with a combined 37.42% global publications share. Top 10 Indian academic groups publish 19.21% of national publications. (Pandey *et al.*, 2021) investigated scientific analysis of Indian AI research publications from 2009-2018 is included in the study. The study suggests India must compete with AI research leaders. To maximize AI application returns, stakeholders must catalyze national research capability by providing a quality research environment, enough financing, research incentives, and IT infrastructure. (Ravichandran & Siva, 2022) investigated 223538 AI research publications were published worldwide. India published 18371 AI papers from 2011 to 2020. The US-India partnership topped the list with 37.52%. China has had the largest publication share (25.58%) in the past decade. Most papers in this research were two-authorship, with 6982 (38.01%). A comprehensive investigation showed that artificial intelligence research papers are rising. (Vatan *et al.*, 2019) The history, traits, and goals of artificial intelligence are explained in this academic essay. Reactive machines, limited memory systems, theory of mind models, and self-awareness mechanisms are all explained in the text. This article discusses AI in literacy, finance, heavy industries, healthcare, news, publishing, transportation, telecommunication maintenance, telephone services, and online consumer services.

### **Objectives of the Study**

The following objectives of this study are as follows:

1. To examine the research output pertaining to the field of Artificial Intelligence between the years 2019 to 2023 in India.
2. To study the highest extension participation in the writing and publishing of AI publications.
3. To study the highest sighted papers in the field of Artificial Intelligence
4. To investigate the funding agency.

### Research Methodology

To identify the research output of Artificial Intelligence in India for a period of 5 years (2019–2023), the data were collected from the SCOPUS dated 18.01.2024. Key-terms such as artificial intelligence. The raw data was computed utilizing RPackage, and Microsoft Excel. R is a language and environment for statistical computing and graphics (R Core Team, 2019). The search query to be performed in order to gather the information: (TITLE-ABS-KEY (artificial AND intelligence) AND AFFILCOUNTRY (india) ) AND (LIMIT-TO (SUBJAREA , "comp") OR LIMIT-TO (SUBJAREA , "engi" ) ) AND (LIMIT-TO (DOCTYPE , "cp") OR LIMIT-TO (DOCTYPE , "ar" ) ) AND (LIMIT-TO (AFFILCOUNTRY , "india" ) ) AND (LIMIT-TO (SRCTYPE , "p" ) OR LIMIT-TO (SRCTYPE , "j" ) ) AND (LIMIT-TO (PUBYEAR , 2019) OR LIMIT-TO (PUBYEAR , 2020) OR LIMIT-TO (PUBYEAR , 2021) OR LIMIT-TO (PUBYEAR , 2022) OR LIMIT-TO (PUBYEAR , 2023) ). Present study restricted to conference papers and articles. A comprehensive search was performed, yielding a total of 12581 results that were then retrieved and downloaded.

### Collecting and Clean-up

The search metadata in Scopus was saved in the CSV file format. The role of a data curator involves identifying and removing duplicates. This review adheres to the standards outlined in the PRISMA statement (Page *et al.*, 2021), and employs a systematic technique to extract the most pertinent material from the literature in a specific field, in order to address a research question or objective. In total 36 duplicates were excluded. A study overview (PRISMA methodology) is provided (Fig.1)

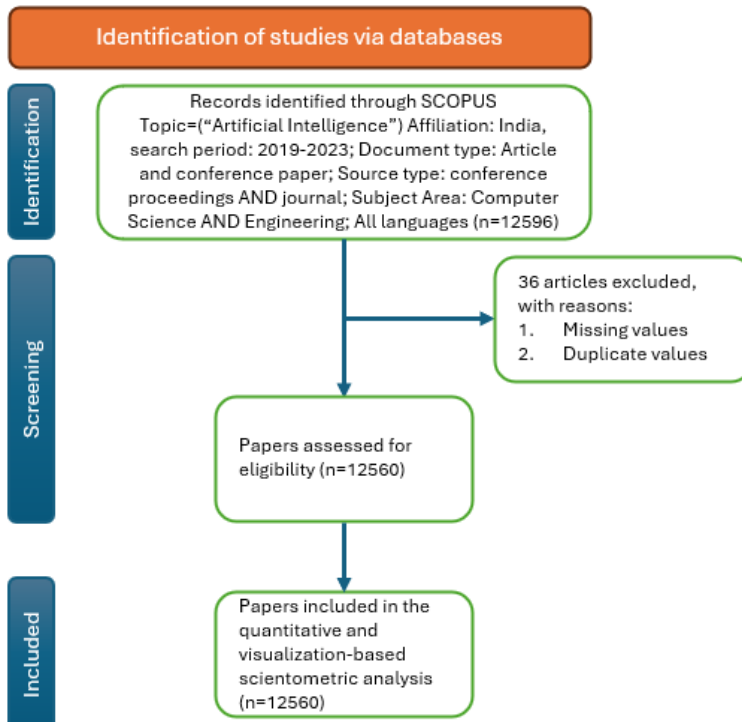

Fig.1 Scrutiny of data as per PRISMA methodology

**Analysis of Data**

*1. Research Output of Artificial Intelligence in India during 2019-2023*

Fig.2 illustrates the trajectory of research publications in the field of Artificial Intelligence from 2019 to 2023. During the designated time frame, cumulative counts of 12,560 research publications were published inside the geographical boundaries of India.

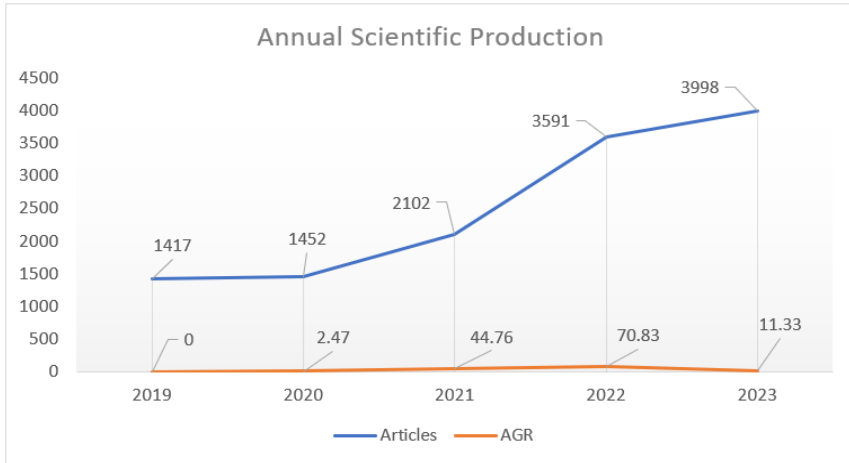

Fig.2 Year-wise Research output of AI

The data shown in Fig.2 clearly demonstrates the year wise research output of Artificial Intelligence. The data was collected from SCOPUS during 2019 to 2023. Total 12,560 records were published. It is found that the highest publication is 3591 in 2022 with AGR 70.83, followed by 2102 papers in 2021 with AGR 44.76. The lowest number of publications in the year 1452 in 2020 with AGR 2.47. The conference paper was the mostly frequently identified, the 7083 documents, representing 52.76% followed by articles, of which a total of 5513 documents, representing 41.07% of the total number of documents.

The Annual Growth Rate (AGR) is computed using the formula provided by Kumar and Kaliyaperumal in 2015 (Santha kumar & Kaliyaperumal, 2015), as stated below:

$$AGR = \frac{\text{EndValue} - \text{FirstValue}}{\text{FirstValue}} \times 100$$

The data presented in the Table I (Top 10 Affiliations Name), indicates that, among the total of 5570 academic institutions, universities with 25,467 documents. The National Institute of Technology has the highest number of papers, accounting for 375 or 1.47% of the total. Following closely is the Uttaranchal University, Dehradun, with 298 articles, representing 1.17%. In fig.3, the proliferation of Artificial Intelligence in academic institutions has been noted among top five institute in India.

The data (Table II Top 10 cited papers) discloses the top ten most referenced publications in this field. Dwivedi, YK from Swansea University, Swansea, United Kingdom is the author with the greatest number of citations, totalling 895. Following closely is Vinay Chamola from the Department of Electrical and Electronics Engineering at BITS-Pilani.



TABLE I LIST OF AFFILIATIONS WITH THE HIGHEST PARTICIPATION IN ARTIFICIAL INTELLIGENCE PAPERS

S. No.	Affiliation	Articles
1	NATIONAL INSTITUTE OF TECHNOLOGY	375
2	UTTARANCHAL UNIVERSITY	298
3	SRM INSTITUTE OF SCIENCE AND TECHNOLOGY	297
4	NIRMA UNIVERSITY	234
5	CHITKARA UNIVERSITY INSTITUTE OF ENGINEERING AND TECHNOLOGY	221
6	LOVELY PROFESSIONAL UNIVERSITY	218
7	AMITY UNIVERSITY	213
8	DELHI TECHNOLOGICAL UNIVERSITY	203
9	INDIAN INSTITUTE OF TECHNOLOGY	199
10	DEPARTMENT OF COMPUTER SCIENCE AND ENGINEERING	197

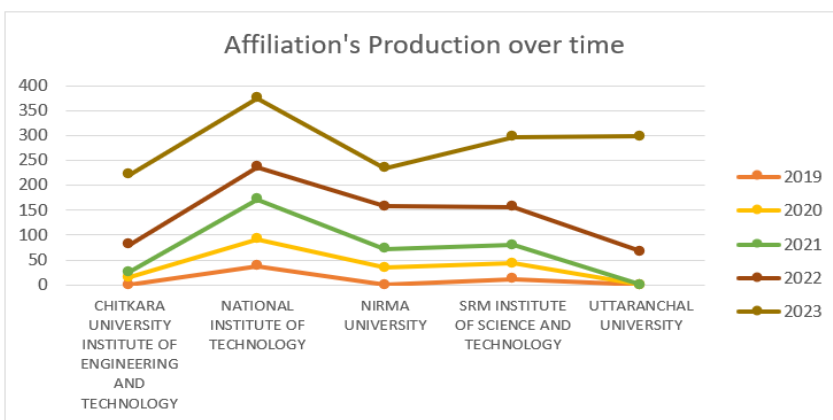

Fig.3 Affiliations Production over time of top five institutions

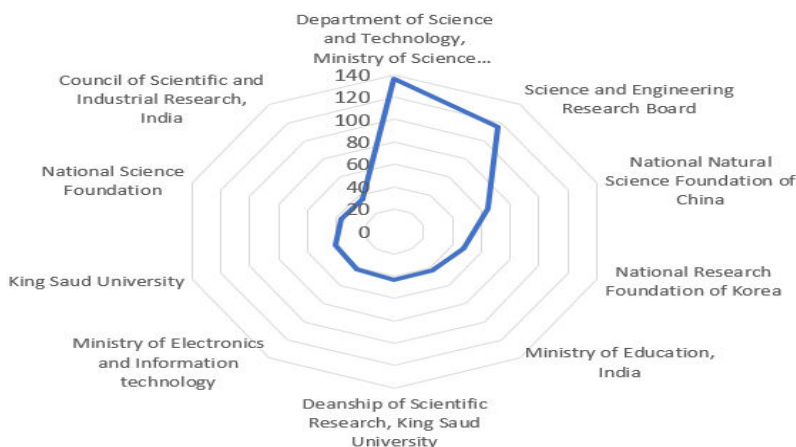

Fig.4 Funding Agencies of Artificial Intelligence

TABLE II LIST OF AUTHOR'S NAMES WITH THE HIGHEST CITATIONS IS ARTIFICIAL INTELLIGENCE PAPERS

S. No.	Paper	DOI	TC	TC PY
1	DWIVEDI YK, 2021, INT J INF MANAGE	10.1016/j.ijinfomgt.2019.08.002	895	223.75
2	CHAMOLA V, 2020, IEEE ACCESS	10.1109/ACCESS.2020.2992341	777	155.40
3	DWIVEDI YK, 2021, INT J INF MANAGE-a	10.1016/j.ijinfomgt.2020.102168	607	151.75
4	DWIVEDI YK, 2020, INT J INF MANAGE	10.1016/j.ijinfomgt.2020.102211	556	111.20
5	CHAABOUNI N, 2019, IEEE COMMUN SURV TUTOR	10.1109/COMST.2019.2896380	506	84.33
6	PRAVEEN KUMAR D, 2019, INF FUSION	10.1016/j.inffus.2018.09.013	461	76.83
7	RAY S, 2019, PROC INT CONF MACH LEARN, BIG DATA, CLOUD PARALLEL COMPUT: TRENDS, PRESPECTIVES PROSPECT, COMITCON	10.1109/COMITCon.2019.8862451	442	73.67
8	GEETHARAMANI G, 2019, COMPUT ELECTR ENG	10.1016/j.compeleceng.2019.04.011	394	65.67
9	DWIVEDI YK, 2023, INT J INF MANAGE	10.1016/j.ijinfomgt.2023.102642	389	194.50
10	MISHRA P, 2019, IEEE COMMUN SURV TUTOR	10.1109/COMST.2018.2847722	379	63.17

Fig.4 depicts the ranking and distribution of the top 10 funding agencies in Artificial Intelligence from India between 2019 and 2023. The data shows that 11221 records of funding agencies, which accounts for 86.95%, were not mentioned by academic papers on artificial intelligence in India. There are a total of 177 financing agencies recorded in the Scopus database. The top 10 funding agencies are displayed in figure 5. The Department of Science and Technology (DST), Ministry of Science and Technology, India supported the most number of publications, with a total of 137. Following closely behind is the Science and Engineering Research Board (SERB), which funded 116 publications. Among the top 10 financing agencies, 4 of them are foreign funding agencies. The National Natural Science Foundation of China supported a total of 65 publications, which is the highest number. The National Research Foundation of Korea funded 48 publications, which is the second highest number.

### Conclusion

This Study Analyses Scopus-Indexed AI Research Articles From 2019 to 2023. SCOPUS Database Is used to analyse artificial intelligence research in this study. According to observation, authors published a maximum of 3998 publications in 2023. Organisations Enhanced research was largely contributed by National Institute of Technology followed by Uttaranchal University. Maximum 137 articles were financed by DST, Ministry of Science & Technology, India. Dwivedi,

YK from Swansea University, Swansea, United Kingdom achieved the most number of citations with a total of 895, followed by Vinay Chamola from the Department of Electrical and Electronics Engineering at BITS-Pilani.

## References

- [1] Bhattacharjee, K. K. (2019). Research Output on the Usage of Artificial Intelligence in Indian Higher Education - A Scientometric Study. *IEEE International Conference on Industrial Engineering and Engineering Management*, 916–919. <https://doi.org/10.1109/IEEM44572.2019.8978798>
- [2] Gupta, B. M., & Dhawan, S. M. (2018). Artificial intelligence research in India: A scientometric assessment of publications output during 2007-16. *DESIDOC Journal of Library and Information Technology*, 38(6), 415–422. <https://doi.org/10.14429/djlit.38.6.12309>
- [3] Kapoor, P., & Upadhyay, A. K. (n.d.). Comparative Study of Citation Databases: Web of Science & Scopus. In A. Hussain & I. Khan (Eds.), *MANLIBNET 2023 International Conference on Empowering Libraries, Connecting Communities Innovation, Collaboration and Entrepreneurship* (pp. 212–223). Management Libraries Network (MANLIBNET).
- [4] Negnevitsky, M. (1997). The History Of Artificial Intelligence Or From The “Dark Ages” To The Knowledge-based Systems. *Transactions on Information and Communications Technologies*, 19, 1–21.
- [5] Page, M. J., Moher, D., Bossuyt, P. M., Boutron, I., Hoffmann, T. C., Mulrow, C. D., Shamseer, L., Tetzlaff, J. M., Akl, E. A., Brennan, S. E., Chou, R., Glanville, J., Grimshaw, J. M., Hróbjartsson, A., Lalu, M. M., Li, T., Loder, E. W., Mayo-Wilson, E., Mcdonald, S. Mckenzie, J. E. (2021). PRISMA 2020 explanation and elaboration: Updated guidance and exemplars for reporting systematic reviews. *The BMJ*, 372. <https://doi.org/10.1136/bmj.n160>
- [6] Pandey, S., Verma, M. K., & Shukla, R. (2021). A scientometric analysis of scientific productivity of artificial intelligence research in India. *Journal of Scientometric Research*, 10(2), 245–250. <https://doi.org/10.5530/JSCIRES.10.2.38>
- [7] R Core Team. (2019). *R: A Language and Environment for Statistical Computing*. R Foundation for Statistical Computing, Vienna, Austria. <https://www.r-project.org>
- [8] Ravichandran, S., & Siva, N. (2022). Artificial Intelligence Research output in India from Scopus Database (2011-2020): A Scientometric Analysis. *International Journal of Research in Library Science*, 8(2), 60. <https://doi.org/10.26761/ijrls.8.2.2022.1537>
- [9] Santha kumar, R., & Kaliyaperumal, K. (2015). A scientometric analysis of mobile technology publications. *Scientometrics*, 105(2), 921–939. <https://doi.org/10.1007/s11192-015-1710-7>
- [10] Tiwari, A., Bardhan, S., & Kumar, V. (2022). A Bibliographic Study on Artificial Intelligence Research: Global Panorama and Indian Appearance. *Library Herald*, 60(4), 15–36. <https://doi.org/10.5958/0976-2469.2022.00036.7>
- [11] Vatan, Sharma, A., & Goyal, S. (2019). Artificial Intelligence on the Move: A Revolutionary Technology. *International Journal of Recent Technology and Engineering (IJRTE)*, 8(4), 12112–12120. <https://doi.org/10.35940/ijrte.d7293.118419>.

# Issues and Challenges of Library Automation in College Libraries of Asansol: A Study

**Biswajit Bhattacharya**

Librarian, Bidhan Chandra College, Asansol, West Bengal, India

E-mail: biswajit.asn@gmail.com

## **Abstract**

*The impact of ICT has completely transformed the concept of conventional library function and services. Instead of browsing the shelves for hours, with a click of a mouse the user can now search the collections of a library and can reach to his/her desired information without wasting time. Library automation helps to organize and produce information in more systematic manner. This study highlights the present status of automation in college libraries of Asansol and challenges faced by the libraries to provide quality services with limited resources.*

**Keywords:** Library, Library Automation, College Library, Library Software, Academic Library

## **Introduction**

Library automation is the process of application of computers with latest technologies to perform library housekeeping operation to provide better service to the users. Automation helps in minimizing human intervention in performing day to day library works so that accuracy can be achieved to run the library in a more disciplined manner. It is the procedure to support the systems and services with the use of computers and other technologies to convert traditional library works into automated one. Libraries are the powerhouse for using Information and Communication Technology (ICT) for automation of its day-to-day work as well as providing search services to the users. Applications of ICT help to avoid repetitive job and save time for both the library staff and the users. Computers are not only used as a data processing tool but also for information storage, organization, access and retrieval.

## **Definitions of Library Automation**

According to Encyclopedia of Library and Information Sciences (Kent, 1977) “Library Automation is the use of automatic and semiautomatic data processing machines to perform such traditional library activities as acquisitions, cataloguing and circulation. These activities are not necessarily performed in traditional ways, the activities themselves are those traditionally associated with libraries; library automation may thus be distinguished from related fields such as information retrieval, automatic indexing and abstracting and automatic textual analysis”.

The Oxford English Dictionary (Simpson & Weiner, 1989) defines automation as “application of automatic control to any branch of industry or science by extension, the use of electronic or mechanical devices to replace human labour”. According to ALA Glossary of Library and Information Science (Levine-Clark & Carter, 2013) automation is “the performance of an operation, a series of operation or a process by self-activating, self-controlling, or automatic means. Automation implies use of automatic data processing equipment such as a computer or other labour-saving devices”.

## **Need of Library Automation**

Information explosion resulted in the large amount of literature in every field of knowledge and libraries are facing challenges to keep these collections in a systematic manner with its limited number of staff and space. Library automation helps to complete the work in a methodical and useful manner. We need library automation for the following reasons:

1. To provide better services to the users in a time bound manner
2. To eliminate human error in various repetitive job in the library
3. To provide new services to the users
4. To improve efficiency of library staff
5. To reduce time span taken by a staff to serve the user
6. To enhance library services and help user to access it remotely
7. To save the time of the user in searching a document
8. To increase cooperation and resource sharing among libraries

### Objectives of the Study

Objectives of this study are:

1. To find out the status of automation in college libraries of Asansol
2. To find out the areas covered in library automation process.
3. To highlight the services offered by the libraries.
4. To identify the challenges faced by the libraries.

### Methodology

The study is conducted by following the descriptive research design specifically survey and content analysis methods were used to collect required data. In order to investigate and analyse the problem of the research and to accomplish the objectives a questionnaire was prepared and personal communication was done to collect required data.

### Scope of the Study

Generally, there are many Govt. sponsored colleges in the district of Paschim Bardhaman but the colleges situated in the city of Asansol namely Asansol Girls' College (AGC), Banwarilal Bhalotia College (BBC) and Bidhan Chandra College (BCC) are taken into consideration for this study.

### Analysis and Findings

The data collected to complete the study has been analysed with the help of different tables to find out the present status of libraries.

#### 1. Library Collections

Collection of a library plays important role for the development of the institution. It is said to be the heart of the institution. The richness of the library depends upon how good its collection is. Two major components for the development of any institution are its collections and its users.

TABLE I LIBRARY COLLECTIONS

Name of the College	Books	Journals & Magazines	Newspapers	e-resources
AGC	34082	13	5	NLIST + Open sources
BBC	61808	12	2	NLIST + Open sources
BCC	36383	12	10	NLIST + Open sources

Table I describes about the number of collections of the libraries and it is found that BBC library is leading in this field with a very good collection of 61808 books while other two libraries have 34082 (AGC) and 36383 (BCC) books respectively.

Two libraries BBC and BCC subscribes almost similar number of journals and magazines (12) for its users while AGC library subscribes one more (13) comparing to other two libraries. BCC library subscribes 10 newspapers for its users while other two libraries AGC and BBC subscribes

only 2 and 5 newspapers respectively for its users. All three libraries provide e-resources to its users through NLIST subscription and open sources available in the web.

### 2. Status of Automation

The application of computer in library routine work to provide better service to the users is the ultimate motive behind library automation process. It needs meticulous planning and execution to complete the process of library automation without hampering users’ interest.

TABLE II STATUS OF AUTOMATION

Name of the College	Fully Automated	Partially Automated	Year of Automation	Software used
AGC		✓	2005	KOHA
BBC		✓	2011	Aadija Library Solutions
BCC	✓		2013	SOUL 3.0

Table II clearly describes that all three libraries are automated and among the libraries the process of automation was started in first in AGC library with the software developed by the BCA department of the college and presently it is using KOHA software.

The process of automation in BBC college library was started with SOUL 2.0 but now it has also changed to new software. Though among the three colleges BCC library was automated in 2013 but only this library is fully automated and using SOUL 3.0 software. AGC library and BBC library is partially automated. Only one library (AGC) is using the open-source software while other two libraries are using proprietary software.

### 3. Areas of Automation

Library automation process is the migration of libraries procedures from manual to computerized, such as from card catalogue to OPAC, or from manual circulation cards to digitized cards with barcodes.

A library software comprises various modules in it and if we use all the modules then only the real purpose of using that software is justified.

TABLE III AUTOMATED MODULES IN THE SOFTWARE

Name of the College	Acquisition	Cataloguing	Circulation	Serial Control	OPAC
AGC		✓	✓		✓
BBC		✓	✓		✓
BCC	✓	✓	✓	✓	✓

Table III defines that out of five modules of the software AGC and BBC libraries using only three modules namely Cataloguing, Circulation and OPAC while BCC library using all the modules of the software including Acquisition and Serial Control along with other three modules.

### 4. Library Services

Library services are most important part for any library. The goal of any good library is not reached until its resources reach the correct users and to bridge the gap of resources and users library services plays the most important role.

TABLE IV LIBRARY SERVICES

Name of the College	Reference	Circulation	Reading Room	Reprography	Online Services	Internet
AGC	✓	✓	✓	✓	✓	✓
BBC	✓	✓	✓		✓	✓
BCC	✓	✓	✓		✓	✓

It is clearly visible from the Table 4 that all three libraries provide Reference, Circulation, Reading Room, Online and internet service for its users. The Reprography service is only provided by the AGC library where as other two libraries (BBC & BCC) don't have this facility for its users.

### 5. Challenges for the Library

Information explosion brought various new challenges for the library as numbers of resources are generating every day and it is very difficult for any library to keep balance while acquiring resources, process it with limited staff, and present it before users with latest technology to maintain quality services.

TABLE V CHALLENGES FACED BY LIBRARIES

Name of the College	Insufficient Fund	Lack of Latest Technology	Inadequate Professional Staff	Lack of Proper Training	Less Awareness in use of Technology	Lack of Space
AGC	✓	✓	✓	✓		✓
BBC	✓	✓	✓	✓	✓	
BCC	✓	✓	✓	✓	✓	

From Table V it is found that all three college libraries are facing the problem of insufficient fund to develop the library collections. To provide best service to the users' latest technology like RFID is not used in any library.

Inadequate number of professional staff and lack of proper training among them is another challenge all three libraries are facing. In two college libraries (BBC & BCC) less awareness in use of technology among users is another challenge it is facing as many students in these colleges are first generation learners. Among the three libraries AGC library is facing space problems in their library where as other two libraries have adequate space to organize its resources.

### Conclusion

Library automation is the need of the hour to provide better services to the users. Automated library helps in maintaining its resources in an organized and systematic manner. It helps to avoid duplication of works and finding the areas which need attention for improvement by analysing various reports generated through the system. But the success of any library automation process needs proper planning and execution right from the beginning so that unnecessary wastage of money, time and manpower can be avoided. Library professionals involved in the process of automation should have proper training and knowledge about the software to complete the process in time a bound manner. Libraries adopting automation should take proper initiative so that all the functions and facilities of library management software can be used to provide quality service to the users.

## References

- [1] Das, D. & Chatterjee, P. (2015). Library automation: An overview. *International Journal of Research in Library Science*, 1(1), 1-7.
- [2] Das, M. (2016). *Issues and challenges of library automation in the college libraries of Assam with special reference to Kamrup district (rural): A study*. Retrieved from <https://ir.inflibnet.ac.in/bitstream/1944/2026/1/22.pdf>
- [3] <http://bbclib.aadijatechnologies.com/index.php> retrieved on 12.01.2024
- [4] <http://bcclib.bccollegeasansol.org/index.php> retrieved on 12.01.2024
- [5] <https://agc-opac.kohacloud.in/cgi-bin/koha/opac-main.pl> retrieved on 12.01.2024
- [6] Jadhav, V. S., Mugade, V. S. & Vedpathak, S. Y. (2022). Status of library automation: A study of management education institutes libraries. *IJFANS international Journal of Food and Nutritional Sciences*, 11(10), 1726-1733.
- [7] Kent, A. (1997). *Encyclopedia of library and information science*. New York: Marcel Dekker.
- [8] Levine-Clark, M. & Carter, T. (2013). *ALA glossary of library and information science* (4<sup>th</sup>ed.).Chicago: American Library Association.
- [9] Patel, S. N. (2014). Library automation: An overview.*International Journal of Research in Humanities and Social Sciences*, 5(2), 35-40.
- [10] Paul, A. K. (2023). Library automation in academic libraries: An introduction with its various aspects. *International Journal of Advances in Engineering and Management (IJAEM)*, 5(2), 35-40.
- [11] Reddy, P. (2001). *Impact of information technology on libraries*. New Delhi: Ess Ess Publications.
- [12] Simpson, J. & Weiner, E. (1989). *The oxford English dictionary* (2<sup>nd</sup> ed.).Oxford: Clarendon Press.



# Emerging Trends and Services in Libraries: A Futuristic Approach

Anil Kumar Mishra<sup>1</sup>, Vrij Kishor Mishra<sup>2</sup> and Dr. Zulfikar Ahmad Khan<sup>3</sup>

<sup>1&2</sup>Research Scholar, <sup>3</sup>Research Guide

<sup>1,2&3</sup>Mangalayatan University, Aligarh, Uttar Pradesh, India

E-mail: 20220654\_anil@mangalayatan.edu.in, vkmdbs@gmail.com, zulfikar212@rediffmail.com

## Abstract

*Information refers to knowledge, facts, or data that is communicated or received. It is the result of processing data through interpretation, analysis, or organization. Information can take many forms, such as text, images, audio, or video. It can be transmitted through various channels, including books, electronic media, oral communication, or the Internet. Library service refers to the range of services that libraries provide to their users. These services are designed to meet the diverse needs of library patrons and promote the effective use of library resources. Library service refers to the range of services that libraries provide to their users. These services are designed to meet the diverse needs of library patrons and promote the effective use of library resources.*

**Keywords:** Library Services, Library Management, ICT, and Digital Services, Emerging Trends in Library.

## Introduction

Information refers to knowledge, facts, or data that is communicated or received. It is the result of processing data through interpretation, analysis, or organization. Information can take many forms, such as text, images, audio, or video. It can be transmitted through various channels, including books, electronic media, oral communication, or the Internet. Information is essential for individuals and organizations to make decisions, gain understanding, and communicate effectively. It plays a crucial role in fields like education, research, business, and everyday life. Access to accurate and reliable information is vital for making informed choices, solving problems, and staying connected with the world in the digital age, the volume of information available is vast and constantly expanding. This has led to a growing need for skills in information literacy, which involves the ability to evaluate, analyse, and effectively use information from various sources. Information is not static but rather dynamic, evolving, and subject to change as new knowledge is discovered or update.

## Library Services

Library service refers to the range of services that libraries provide to their users. These services are designed to meet the diverse needs of library patrons and promote the effective use of library resources. Common library services include:

1. *Lending and Borrowing:* Libraries allow users to borrow books, audio-books, DVDs, and other materials for a specific period. They also facilitate the return and renewal of borrowed items.
2. *Reference and Research Assistance:* Librarians provide guidance and support to users in finding information, conducting research, and answering questions. They help patrons navigate library catalogues, databases, and other resources.
3. *Information Literacy Instruction:* Libraries offer training and workshops to help users develop critical thinking and information literacy skills. These sessions teach patrons how to evaluate sources, use citation tools, and conduct effective research.

4. *Digital Resources and Technology Access*: Many libraries provide access to computers, the internet, and digital resources, such as e-books, online databases, and digital magazines. They may offer assistance in using these technologies.
5. *Children and Youth Services*: Libraries often have programming and resources specifically for children and young adults. This can include story times, summer reading programs, book clubs, and homework assistance.
6. *Community Programs and Events*: Libraries host community events, workshops, author talks, and book clubs to engage and connect with the local community. These programs promote literacy, lifelong learning, and cultural enrichment.
7. *Inter Library Loan*: Libraries can request materials from other libraries on behalf of their patrons if they do not have a specific item in their collection. This allows users to access a broader range of resources.

Overall, library service aims to meet the information and educational needs of library users, promote access to knowledge, and support lifelong learning. Libraries have long been known as centres of knowledge and information and they continue to evolve to meet the changing needs of their communities. In recent years there have been several trends and services that have emerged in libraries offering a glimpse into the future of these vital institutions. Let's take a closer look at some of these trends and services.

1. *Digital Libraries*: With the rise of digital technology libraries are embracing digital resources and creating online platforms for accessing books journals research papers and other digital content. Digital libraries offer convenience and accessibility allowing users to access materials from anywhere at any time.
2. *Maker Spaces*: Libraries are shifting from being solely book repositories to becoming creative spaces. Maker spaces provide tools equipment and technology to promote hands-on learning and innovation. These spaces encourage patrons to learn new skills experiment with technology and engage in collaborative projects. Libraries are creating spaces where users can explore and create using tools like 3D printers, laser cutters, and audio/video recording equipment. These spaces encourage hands-on learning and creativity.
3. *Virtual Reality (VR) And Augmented Reality (AR)*: Libraries are integrating virtual and augmented reality technologies to create immersive learning experiences. Patrons can explore historical landmarks visit far-off places or dive into virtual worlds through VR headsets. AR enhances the physical environment by overlaying digital information making learning more interactive and engaging.
4. *Coding and Technology Programs*: Libraries recognize the importance of digital literacy and are offering coding workshops technology training and coding clubs for all age groups. These initiatives empower individuals to acquire skills for the digital age and prepare them for future career opportunities.
5. *Community Engagement Initiatives*: Libraries are strengthening their role as community hubs by organizing events workshops and seminars that cater to diverse interests and age groups. These initiatives promote community engagement social interaction and lifelong learning.
6. *Data Literacy*: With the increasing importance of data in various fields libraries are focusing on data literacy programs. These programs teach individuals how to find analyze and interpret data effectively enabling them to make informed decisions and be critical consumers of information.
7. *Sustainable Practices*: Libraries are embracing sustainability by incorporating eco-friendly practices. Initiatives include implementing energy-efficient lighting recycling programs promoting digital resources to reduce paper usage and hosting events that promote environmental awareness and conservation.

8. *Mobile Libraries:* To reach underserved communities libraries are adopting mobile library services such as bookmobiles or library vans. These mobile units bring library resources programs and services to remote areas senior centres schools and other locations without easy access to a physical library.
9. *Personalized Services:* Libraries are increasingly using technology to offer personalized recommendations based on users' interest's preferences and reading habits. This can include tailored reading lists curated book suggestions and customized digital content. These services enhance the user experience and ensure that library resources align with individual needs.
10. *Collaboration and Partnerships:* Libraries are collaborating with various organizations such as schools universities museums and local businesses to expand their services and reach a wider audience. These strategic partnerships allow libraries to offer a broader range of resources expertise and programming.

As libraries continue to adapt to the changing needs of their communities these trends and services offer valuable insights into the future of these institutions. By embracing technology fostering creativity and promoting community engagement libraries will remain vital centres of learning information and cultural, Initiatives taken by the libraries in the modern era are:

1. *Digitization and Online Services:* Libraries are embracing technology and offering digital services such as e-books, online databases, streaming services, and virtual programs. This allows users to access library resources from anywhere and at any time.
2. *Focus on Community Engagement:* Libraries are shifting their focus towards becoming community hubs. They host events, workshops, and programs that cater to the needs and interests of their local communities. This includes providing social and educational support for various groups like seniors, students, and immigrants.
3. *Sustainability and Eco-Friendly Initiatives:* Libraries are incorporating sustainable practices into their operations by using energy-efficient technologies, promoting recycling, and offering resources on climate change and environmental issues.
4. *Data Literacy and Information Literacy:* As the amount of information available continues to grow, libraries are taking a proactive role in teaching users how to critically evaluate and use information effectively. They offer workshops and programs on data literacy skills and digital citizenship.
5. *Accessibility and Inclusivity:* Libraries are working to ensure that their services and spaces are inclusive and accessible to all users, including those with disabilities. They provide resources and facilities such as assistive technologies, accessible formats, and quiet spaces for users with sensory sensitivities.
6. *Health and Wellness Programs:* Libraries are increasingly offering programs and resources related to health and wellness. This includes providing access to fitness equipment, hosting exercise classes, offering mental health resources, and partnering with local healthcare providers for screenings and workshops.
7. *Cultural and Language Diversity:* Libraries are diversifying their collections and programming to reflect the multicultural communities they serve. They provide materials in multiple languages, host cultural events, and partner with community organizations to celebrate diversity.
8. *Collaboration and Partnerships:* Libraries are actively seeking partnerships with other organizations and institutions to expand their reach and share resources. This includes partnerships with schools, museums, community centres, and local businesses.
9. *Personalized and Adaptive Services:* Libraries are using data and technology to better understand user preferences and tailor their services accordingly. This may include

personalized reading recommendations, customized programming, and adaptive technology for users with special needs.

### **Purpose and Issues**

In the future, libraries are likely to continue involving to meet the changing needs of their communities. Here are some potential developments are:

1. *Virtual Reality and Augmented Reality:* Libraries may incorporate virtual reality (VR) and augmented reality (AR) technology to enhance learning experiences. Users could explore virtual libraries, attend virtual author talks, or participate in interactive AR-based educational activities.
2. *Artificial Intelligence (AI) Integration:* Libraries may utilize AI technology to improve library services. AI-powered chat bots could provide virtual reference assistance, while machine learning algorithms could help analyze and organize library data more efficiently.
3. *Integration of Internet of Things (IoT) Devices:* Libraries may incorporate IoT devices to streamline operations and create more interactive spaces. Smart shelves could automatically track inventory, IoT sensors could monitor environmental conditions, and interactive displays could provide real-time information and recommendations.
4. *User-Centered Design:* Libraries may adopt a more user-centered approach by involving users in the design and planning of library spaces and services. User feedback and data analysis could inform decisions about resource allocation and program development.
5. *Data-Driven Decision-Making:* Libraries may utilize data analytics to make informed decisions about collection development, programming, and outreach strategies. Analysing user behaviour and preferences could help libraries better understand and cater to their community's needs.
6. *Emphasis on Lifelong Learning:* Libraries may increasingly focus on providing opportunities for lifelong learning. They could offer more workshops, classes, and resources to support ongoing education, skill development, and career advancement.
7. *Mobile Libraries and Pop-Up Services:* Libraries may explore innovative ways to reach underserved populations or areas without traditional library access. Mobile libraries or pop-up libraries could bring books, digital resources, and library services directly to communities.
8. *Collaboration with Emerging Industries:* Libraries may forge partnerships with emerging industries such as technology companies, start-ups, and creative sectors to create specialized programs and resources. This collaboration could foster innovation and support economic growth within the community.
9. *Sustainable and Environmentally Friendly Practices:* Libraries may continue to implement sustainable practices, such as reducing energy consumption, utilizing eco-friendly materials, and promoting recycling. They may also incorporate environmental education and resources on sustainability topics.
10. *Continued Emphasis on Equity and Access:* Libraries will likely persist in their efforts to bridge the digital divide and ensure equitable access to information and technology. This may involve expanding digital literacy programs, providing internet access, and addressing affordability barriers for digital resources.

### **Some of the Latest Trends in Libraries Include**

1. *Digital Library Resources:* Libraries are increasingly offering e-books, audio-books, and digital magazines that can be accessed online or through mobile apps.
2. *Maker Spaces:* Libraries are creating maker spaces to provide patrons with equipment and tools for activities such as 3D printing, robotics, coding, and crafting.

3. *Collaborative Learning Spaces*: Libraries are transforming their spaces to accommodate group work, with comfortable seating, whiteboards, and technology for collaboration.
4. *Community Engagement*: Libraries are becoming more involved in their communities by organizing events, workshops, guest speakers, and hosting social activities to support local interests.
5. *Virtual Reality and Augmented Reality*: Libraries are adopting virtual reality and augmented reality technologies to offer immersive experiences and educational simulations.
6. *Data Literacy and Analytics*: With the rise of big data, libraries are empowering users to understand and analyse data through workshops and training programs.
7. *Personalized Recommendations*: Libraries are using algorithms and machine learning to provide personalized reading recommendations to their users based on their interests and reading history.
8. *Green Libraries*: Libraries are incorporating sustainable practices in their operations, such as energy-efficient lighting (using solar, wind, hydro-power, bio-fuels etc.) recycling initiatives, and eco-friendly building materials.
9. *Community Partnerships*: Libraries are collaborating with local organizations, businesses, and schools to provide resources and services that meet the community's needs.
10. *Library as a Cultural and Social Hub*: Libraries are embracing their role as a community centre, hosting cultural events, art exhibits, and book clubs, and providing spaces for people to connect and socialize.

### **Importance of the Library**

Libraries play a crucial role in society for a variety of reasons. Here are some of the key importance and Purposes of libraries:

1. *Access to Information*: Libraries provide free and open access to a wide range of resources, including books, journals, databases, multimedia materials, and internet access. They ensure that people have access to knowledge and information regardless of their socioeconomic background.
2. *Promoting Literacy and Education*: Libraries are essential in promoting literacy skills and fostering a love for reading. They provide a vast collection of books and learning materials that encourage lifelong learning and educational development.
3. *Supporting Lifelong Learning*: Libraries offer opportunities for learning beyond formal education. They provide workshops, training programs, and resources to support professional development, personal enrichment, and the acquisition of new skills.
4. *Digital Inclusion*: Libraries bridge the digital divide by providing access to technology and digital resources for individuals who might not have the means to access them elsewhere. They offer computer and internet access, as well as training on digital literacy skills.
5. *Community Engagement and Social Cohesion*: Libraries serve as community hubs where people can connect, interact, and participate in social and cultural activities. They often host events, lectures, workshops, and exhibitions that promote engagement, dialogue, and community bonding.
6. *Preservation of Cultural Heritage*: Libraries are crucial for preserving and archiving cultural heritage, historical records, and local knowledge. They collect and provide access to materials that document and celebrate the history, traditions, and achievements of a community or region.
7. *Information Literacy and Critical Thinking*: Libraries play a vital role in teaching information literacy skills, helping users navigate and evaluate the vast amount of information available. They promote critical thinking, research skills, and the ability to distinguish reliable sources from misinformation.

8. *Lifeline during Emergencies*: Libraries can act as emergency information centres during times of crisis or natural disasters. They provide access to important updates, resources, and support for impacted communities.
9. *Equal Access and Inclusivity*: Libraries strive to provide equitable access to information and resources for everyone in the community, regardless of age, gender, abilities, or financial resources. They aim to create an inclusive and welcoming environment for all individuals.
10. *Intellectual Freedom and Democracy*: Libraries uphold the principles of intellectual freedom, ensuring that everyone has the right to access diverse viewpoints, ideas, and opinions. They serve as bastions of democracy, fostering a tolerant and open society where freedom of speech and expression are valued.

### **The Top 9 Current Trends in Library and Information Services**

1. Academic ethics, integrity and Plagiarism
2. Cloud Computing
3. RFID
4. Internet of things(IoT)
5. Big data and data visualization
6. AI (Artificial Intelligence)
7. Mobile based library services
8. Electronic resources management
9. Intelligent library search

### **Latest Services of the Library**

Information communication technology (ICT) has significantly transformed and improved library services in recent years. Here are some of the latest services and advancements made possible through ICT:

1. *Online Catalogues and Databases*: Libraries now provide online catalogues and databases allowing users to search and access a vast range of resources remotely. This includes books journals articles e-books audio-visual materials and more. Users can check availability view summaries and access full-text materials online.
2. *E-Books and Audio Books*: Library collections now include digital formats such as e-books and audio books. Users can borrow and download these materials onto their devices from anywhere eliminating the need to visit the physical library. E-book lending platforms and apps have made reading more accessible and convenient.
3. *Virtual Reference Services*: Libraries offer virtual reference services to help patrons with their research needs. These services include online chat email and video consultations with librarians. Users can seek assistance and receive guidance remotely ensuring that their information needs are met without visiting the library in person.
4. *Digital Libraries and Archives*: Many libraries have digitized their collections and made them available online. This allows users to access historical documents manuscripts photographs and other valuable resources from anywhere in the world. Digital libraries and archives promote scholarly research and the preservation of cultural heritage.
5. *Online Renewals and Reservations*: Using ICT libraries have streamlined their administrative processes. Patrons can renew borrowed materials online avoiding the need to physically visit the library. Additionally, users can reserve books and other resources online receiving notifications when the items become available.
6. *Virtual Learning Spaces*: Libraries have transformed their physical spaces to create virtual learning environments. Online platforms enable users to engage in collaborative activities

participate in virtual book clubs attend webinars and workshops and access educational resources. Virtual learning spaces extend library services beyond physical boundaries.

7. *Mobile Apps*: Libraries have developed mobile applications to enhance user access and engagement. These apps provide features such as catalogue searches account management e-book borrowing push notifications for due dates and reserved books and event calendars. Mobile apps make library services readily available on smart phones and tablets.
8. *Data Analytics and Usage Statistics*: Libraries use ICT tools to gather data on resource usage user behaviour and preferences. Data analytics help libraries make informed decisions such as improving their collections identifying popular resources and understanding user needs. This enables libraries to tailor their services to better serve their patrons.

These advancements in library services made possible through ICT have revolutionized the way people access utilize and interact with library resources. They have expanded access to information improved convenience and facilitated lifelong learning in the digital age. Present scenario of the library services in the Modern world: Libraries in the modern world continue to provide a wide range of services to their patrons. Here are some of the key services offered by libraries today:

1. *Access to Information*: Libraries are still a primary source of information in the digital age. They offer a vast collection of books journals reference materials and digital resources that provide valuable information across various subjects. Libraries help users navigate through vast amounts of data and provide guidance on reliable sources.
2. *Digital Resources*: Libraries have adapted to the digital age by offering a range of online resources. Many libraries provide access to e-books audio books digital magazines and research databases which can be borrowed and accessed remotely. These resources cater to the growing demand for digital content and provide users with easy access to information.
3. *Internet Access*: Not everyone has reliable internet access at home so libraries often provide free internet access to bridge this digital divide. This service is essential for individuals who need to complete online research job applications or access online educational resources.
4. *Education and Workforce Development*: Libraries serve as educational support centers by offering various programs and resources for learners of all ages. They assist with homework tutoring programs and access to online learning platforms. Libraries may also organize workshops training sessions and events focused on job searching resume writing and career development.
5. *Community Engagement*: Libraries play a vital role in fostering community engagement. They organize cultural events book clubs reading programs author visits and exhibitions creating spaces for people to gather participate and share ideas. Libraries also serve as meeting places and provide meeting rooms for community organizations and groups.  
**Reference Services**: Librarians are highly trained professionals who assist users in finding information and conducting research. They provide reference services helping users with their queries suggesting relevant resources and guiding them on effective research strategies. Librarians can help locate books articles and other materials both within the library and through online resources.
6. *Digital Literacy*: Libraries recognize the importance of digital literacy skills in today's society. They offer various programs and workshops to help individuals develop digital skills including computer basics internet usage online safety and navigating digital platforms. This empowers individuals to fully participate in the digital world.
7. *Preservation of Cultural Heritage*: Libraries understand the significance of preserving our cultural heritage. They maintain collections of rare books documents manuscripts and historical records ensuring their long-term preservation and accessibility to researchers and

the public. Libraries often digitize and make these collections available online contributing to the preservation and dissemination of cultural heritage. Library service refers to the range of services that libraries provide to their users. These services are designed to meet the diverse needs of library patrons and promote the effective use of library resources.

### Conclusion

In Conclusion, the latest trends in library and information science focus on the digitization of resources, promoting open access, managing data effectively, enhancing user experience, improving information literacy skills, fostering collaboration, embracing AI technologies, and promoting diversity and inclusion. These trends reflect the evolving role of libraries as dynamic and inclusive institutions in the digital age.

### References

- [1] Baba, Abdul Majid; Bhardwaj, Raj Kumar; Dhaka, S.S.; Ashraf, Tariq & Hasan, Nabi (Eds.). (2018). *Developing Smart Libraries: Changes, Challenges, Issues & Strategies: Proceedings of the 3rd International Conference of Asian Libraries (ICAL-2018)*. (pp. xix, 688). New Delhi: Asian Library Association.
- [2] Barathi, S., Loganathan, G., & Rajan, V. R. (2017). Emerging technological innovations in library knowledge management and services. *Advances in Computational Sciences and Technology*, 10(5), 1479-1486
- [3] Carole, M. P. N (2008). *Keys trends affecting librarians*. Office of Policy and Analysis, Smithsonian Institutes, Washington DC
- [4] Cassell, K. A., & Hiremath, U. (2023). *Reference and information services: An introduction*. American Library Association.
- [5] Cooke, N. A. (2016). *Information services to diverse populations: Developing culturally competent library professionals*. Bloomsbury Publishing USA.
- [6] Dempsey, L. (2012). Libraries and the informational future: some notes. *Information services & use*, 32(3-4), 203-214.
- [7] Evans, G. E. (1995). *Developing Library and Information Center Collections. Library Science Text Series*. Libraries Unlimited, Inc., PO Box 6633, Englewood, CO 80155-6633 (cloth: ISBN-1-56308-183-0, \$55, \$66 outside North America; paper: ISBN-1-56308-187-3, \$37.50, \$45 outside North America).
- [8] Feather, J., & Sturges, P. (Eds.). (2003). *International encyclopedia of information and library science*. Routledge.
- [9] Greer, R. C., & Agada, J. (2010). *Assessing information needs: managing transformative library services*. Bloomsbury Publishing USA.
- [10] Hill, H. (2013). Disability and accessibility in the library and information science literature: A content analysis. *Library & Information Science Research*, 35(2), 137-142.
- [11] Jagdish, A. (2008). Innovative technologies for building libraries of tomorrow. Book of Papers at a seminar Organised by Ahmedabad Library Network, 49-65. Retrieved from <http://ir.inflibnet.ac.in:8080/ir/bitstream/1944/1460/1/5.pdf>
- [12] Kataria, Sanjay *et al.*, (Ed.) (2015). *Proceedings of 4th International Symposium on Emerging Trends and Technologies in Libraries and Information Services*. Available at <http://ieeexplore.ieee.org/xpl/mostRecentIssue.jsp?punumber=7038743>
- [13] Kataria, Sanjay *et al.*, (Ed.) (2018). *Proceedings of 5th International Symposium on Emerging Trends and Technologies in Libraries and Information Services*. Available at <https://ieeexplore.ieee.org/xpl/mostRecentIssue.jsp?punumber=8467458>
- [14] Kataria, Sanjay *et al.*, (Ed.). (2012). *Future of Libraries in Digital Age*. KBD Publication, New Delhi, 2012



- [15] Kataria, Sanjay Nigam BS and Shukla, RK (Ed.) (2008). *Emerging Trends and Technologies in Libraries and Information Services*. KBD Publication, New Delhi, 2008
- [16] Kataria, Sanjay, John Paul Anbu K, Shri Ram (Ed.) (2010). *Emerging Technologies and Changing Dimensions of Libraries and Information Services*. KBD Publication, New Delhi, 2010
- [17] Kaushik, A. (2018). *Library and Information Science in the Age of MOOCs*. USA: IGI Global. doi:10.4018/978-1-5225-5146-1
- [18] Kuhlthau, C. C. (2004). *Seeking meaning: A process approach to library and information services* (Vol. 2). Westport, CT: Libraries Unlimited.
- [19] Lancaster, F. W. (1977). *The measurement and evaluation of library services*. Washington, DC.
- [20] Letha, M. M. (2006). Library portal: A tool for web enabled information services. *DESIDOC Journal of Library & Information Technology*, 26(5).
- [21] Matthews, J. R. (2017). *The evaluation and measurement of library services*. Bloomsbury Publishing USA.
- [22] Moran, B. B., & Morner, C. J. (2017). *Library and information center management*. Bloomsbury Publishing USA.
- [23] Rhoda, B. (2008). Current trends in libraries in the digital era. Book of papers at a seminar organised by Ahmedabad Library Network (ADINET), Information and Library Network Centre (INFLIBNET), and Ahmedabad Management Association (AMA). Retrieved from <http://www.alibnet.org/public/bookofpaper/6.pdf>
- [24] Rubin, R. E., & Rubin, R. G. (2020). *Foundations of library and information science*. American Library Association.
- [25] Tenopir, C. (2003). Use and users of electronic library resources: An overview and analysis of recent research studies. *Council on Library and Information resources*.
- [26] Uddin, J., & Hasan, N. (2012). Use of information technology in library service: A study on some selected libraries in Northern part of Bangladesh. *International Journal of Library and Information Science*, 4(3): 34-44. Retrieved from [http://www.academicjournals.org/app/webroot/article/article1379684073\\_Uddin%20nd%20Hasan.pdf](http://www.academicjournals.org/app/webroot/article/article1379684073_Uddin%20nd%20Hasan.pdf).

# Investigating the Influence and Obstacles of AI-Driven Chatbots in Educational Settings: Insights for 2023

Zohaib Hassan Sain  
Superior University, Pakistan  
E-mail: zohaib3746@gmail.com

## Abstract

*Artificial intelligence (AI) is a dynamic system, endowed with learning capabilities, problem-solving acumen, and a grasp of human language nuances. In education, AI emerges as a powerful ally, offering virtual mentors, voice-activated assistance, innovative educational content, intelligent classrooms, automated assessments, and personalized learning experiences. Within this transformation, the Chat GPT system, an AI chatbot, takes centre stage. Its prowess in generating diverse styles, from formal to creative, brings both opportunities and challenges. Efficiency in processing textual inputs, while advantageous for information retrieval, may risk diminishing content originality, potentially leading to pedagogical staleness. Yet, Chat GPT's mastery in understanding human language enables it to craft creative pieces akin to human-authored work. Exploring its impact on students' creative writing skills, this research adopts a qualitative approach, analyzing scholarly journals. As AI systems like Chat GPT evolve in education, they offer efficiency but require vigilance to preserve the creative essence. Recognizing their potential to nurture creativity, this research illuminates the evolving educational landscape in the AI-driven era.*

**Keywords:** Artificial Intelligence, Chat-GPT, Education.

## Introduction

Artificial Intelligence (AI) is a pivotal component of technological progress, revolutionizing the landscape of education and learning. In the realm of education, various AI-driven systems, including virtual mentors, voice assistants, innovative content delivery, smart classrooms, automated assessments, and personalized learning, have become prevalent. The primary users of these systems, particularly in the era of Industry 4.0, are Generation Y, Z, and Alpha, commonly referred to as digital natives due to their advanced understanding of computers and the internet (Gazali, 2018).

As emphasized by Fahimirad and Kotamjani (cited in Prastiwi, 2019), the integration of educational technology, notably Artificial Intelligence, is reshaping the educational paradigm. This transformation necessitates educational institutions to adapt their learning systems to enhance graduates' competitiveness in developing critical, creative, and collaborative thinking abilities. However, amidst the opportunities brought by AI in education, challenges and demands arise, particularly for educators. Kartadinata (cited in Gazali, 2018) notes that 54% of internet users in Indonesia belong to the digital generation, highlighting the need for teachers to navigate the complexities of educating a generation deeply connected to the internet. Teachers are expected to possess competence in utilizing AI systems (OECD, 2018). Despite the integration of AI-based educational platforms with teachers, challenges emerge as the teacher's role may shift from collaboration to competition with machine-driven tasks, such as those performed by Chat-GPT, an AI-based chatbot system.

One notable concern is the potential impact on students' skills, including critical, creative, and collaborative thinking, as the use of AI-driven systems, particularly chatbots, might diminish the emphasis on these essential skills. This poses a challenge to the educational landscape in fostering

students' cognitive competence and critical thinking. This research aims to delve into the implications of AI-based systems, specifically the GPT Chat system, on education and learning. It is anticipated that this study will stimulate further research, particularly in the context of Indonesia, where exploration of the GPT chatbot system's application in education remains limited.

### **Problem Statement**

The integration of AI-driven Chat GPT in educational settings presents a nuanced challenge, particularly concerning its influence on students' creative writing skills. As AI technology, including chatbots, gains prominence in classrooms, the balance between leveraging its efficiency for information retrieval and safeguarding the authenticity and originality of students' work becomes crucial. The inherent risk lies in the potential diminishment of content originality, leading to a form of pedagogical staleness. The Chat GPT system's proficiency in generating diverse styles, while a notable asset, raises questions about the preservation of the creative essence in students' writing. Consequently, the problem at hand revolves around understanding how AI, through tools like Chat GPT, impacts the creative writing abilities of students in educational environments.

### **Significance of the Study**

The significance of this study lies in unravelling the multifaceted implications of AI-driven Chat GPT in the realm of education, specifically focusing on its influence and obstacles in the context of creative writing skills. With AI becoming an integral part of the educational landscape, exploring the dynamics between technology and creativity is imperative. Understanding the nuances of Chat GPT's role in students' writing processes provides insights into the evolving educational methodologies in the AI-driven era. By shedding light on both the opportunities and challenges posed by Chat GPT, educators, policymakers, and researchers can make informed decisions about integrating AI tools in educational settings. This study contributes to the broader discourse on AI in education by emphasizing the need for vigilance in preserving the creative essence while harnessing the efficiency offered by these technological advancements.

### **Research Methodology**

Employing a Descriptive Qualitative Analysis Methodology, This Research Aims to Offer A comprehensive exploration of the utilization of the GPT Chat system within Artificial Intelligence-driven education and learning. The chosen approach involves an extensive library research methodology, drawing insights from articles in journals analogous to the thematic focus of this study. The qualitative nature of the analysis facilitates a nuanced understanding of the implications and applications of the GPT Chat system in the educational landscape. Through this methodological framework, the study endeavours to shed light on the multifaceted dimensions, challenges, and potentials associated with integrating the GPT Chat system in educational settings. As the research unfolds, it seeks to contribute valuable insights into how this particular AI-driven system impacts pedagogical approaches and student engagement. The utilization of a qualitative descriptive analysis method ensures a thorough exploration and synthesis of information, allowing for a rich and contextual understanding of the subject matter. The selection of data sources from articles in relevant journals contributes to the scholarly rigor and relevance of the study, positioning it within the broader discourse on AI in education.

### **Results and Discussions**

Artificial intelligence (AI) is extensively applied in education, particularly in well-equipped schools. Among various AI technologies, the GPT Chat system, alongside virtual mentors, voice assistants, innovative content delivery, smart classrooms, automatic assessments, and personalized

learning, plays a crucial role. GPT Chat, an AI-based chatbot, enhances interaction and simplifies tasks by responding to user queries in text or voice, aiding students in their assignments (Faiz, 2003). Despite its utility, GPT Chat poses challenges, particularly in the development of students' creative writing skills. In the context of learning, Chat GPT has limitations that prevent it from replacing human interaction effectively. These limitations include the need for direct emotional interaction, teacher modelling in the learning process for academic success, the demand for creativity in generating ideas and innovations, an inability to capture individual learning nuances, potential social and psychological impacts on users, and the risk of impeding critical thinking (Hutson, 2022). In the paradigm shift towards 21st-century learning, educators face the responsibility of transforming from transmitters to facilitators, mentors, and consultants. This transformation emphasizes comprehensive assessments, fostering creativity, and leveraging media as learning tools (21st-century learning construct, 2021). While AI tools like Chat GPT have the potential to revolutionize education, they also require ethical use and responsible integration into the learning process.

The study acknowledges that the application of Chat GPT in education is a topic of ongoing exploration, and its impact on creative writing skills needs careful consideration. The utilization of Chat GPT in creative writing assignments poses challenges, as students may bypass essential steps and stages in completing assignments, hindering the natural development of writing skills through learning and practice (Saraswati, 2014). Creative writing, an outcome of creativity, requires continuous guidance and processes, contributing to students' cognitive development and creativity. In the learning process, a communicative and appreciative-based approach, respecting students' characteristics and appreciating their writing results, fosters creative writing skills. Teachers play an irreplaceable role in facilitating communicative interactions and providing guidance in the learning process.

To address the challenges posed by Chat GPT in creative writing assignments, teachers can adopt strategies such as incorporating paper-based assignments, enabling a more traditional evaluation process. These strategies aim to measure students' writing skills actively and creatively, aligning with the idea that learning actively and creatively creates optimal conditions for student development (Brown, cited in Kurniawan, 2013).

In conclusion, while AI technologies like Chat GPT present novel opportunities in education, particularly in technology integration, teachers must carefully navigate the challenges to ensure responsible use. The study emphasizes the irreplaceable role of teachers in fostering creativity and communication, which Chat GPT cannot entirely substitute. As AI technologies continue to evolve, teachers face ongoing challenges in adapting and optimizing their use to enhance the educational process.

## **Conclusion**

Based on the findings and subsequent discussion, Chat GPT emerges as a valuable tool in education and learning due to its capacity to generate responses based on user-entered keywords. However, it is essential to recognize that not all aspects of these capabilities contribute positively to the development of various student skills, particularly in areas such as creative writing. Therefore, it becomes imperative for educators to devise strategies that extend beyond internet-based learning, which may be prone to misuse by students during assignment completion. One effective strategy involves incorporating the use of traditional paper as a medium, as recommended by Cassidy (2022). This approach serves as a means of process control and assessment when students are tasked with assignments related to creative writing. By introducing

this strategic element, teachers can ensure a more comprehensive evaluation of students' skills, mitigating potential challenges associated with the overreliance on internet-based platforms.

### **Future Research and Limitations**

Looking ahead, future research endeavours should delve deeper into refining the integration of AI-driven technologies like Catgut in educational contexts. Exploring strategies to mitigate the potential risks associated with diminishing content originality while maximizing the benefits of efficiency in information retrieval would be instrumental. Additionally, investigating the long-term impact of AI-driven educational tools on students' overall cognitive and creative development is an avenue for future exploration. However, it's essential to acknowledge certain limitations in this study. The qualitative approach, while providing in-depth insights, might limit the generalizability of findings. The rapidly evolving nature of AI technology necessitates ongoing research to capture the latest developments and their implications. Furthermore, ethical considerations surrounding AI in education should be a focal point for future research endeavours, ensuring responsible and equitable integration of these technologies in diverse educational settings.

### **References**

- [1] Cassidy, C. (2023, January 10). Australian universities to return to 'pen and paper' exams after students caught using AI to write essays. *The Guardian*. <https://www.theguardian.com/australia-news/2023/jan/10/universities-to-return-to-pen-and-paper-exams-after-students-caught-using-ai-to-write-essays> Hutson 2022
- [2] Fais, Aiman dan Kurniawati, Imas. 2023. Eduktaif: Jurnal Pendidikan Volume 5 Nomor 1 Bulan Februari. Universitas Muhammadiyah, Cirebon.
- [3] Hilir., A. (2021). *Teknologi Pendidikan di Abad Digital*.
- [4] Hutson, M. (2022). Could AI help you to write your next paper? *Nature*, 611(7934), 192–193. <https://doi.org/10.1038/d41586-022-03479-w>
- [5] Kurniawan, 2013. Pengembangan Lembar Kerja Siswa (LKS) Dengan Pendekatan Inkuiri Terbimbing Untuk Mengoptimalkan Kemampuan Berpikir Kritis Peserta Didik Pada Materi Listrik Dinamis SMA Negeri 3 Purworejo Kelas X Tahun Pelajaran 2012/2013. Universitas Muhammadiyah Purworejo
- [6] Lund, B. D., & Wang, T. (2023). Chatting about ChatGPT: how may AI and GPT impact academia and libraries?. *Library Hi Tech News* Munir. (2017). *Pembelajaran Digital*. In Alfabeta Risma Dwi Saraswati, 2014, Pengaruh teknik creative writing terhadap keterampilan menulis puisi siswa sekolah dasar. Skripsi, Universitas Pendidikan Indonesia
- [7] Patil, A. S., & Abraham, A. (2010). Intelligent and Interactive Web-Based Tutoring System in Engineering Education: Reviews, Perspectives and Development. In *Computational Intelligence for*
- [8] Pham, S. T., & Sampson, P. M. (2022). The development of artificial intelligence in education: A review in context. *Journal of Computer Assisted Learning*, 38 (5), 1408-1421
- [9] Rudolph, J., Tan, S., & Tan, S. (2023). ChatGPT: Bullshit spewer or the end of traditional assessments in higher education. *Journal of Applied Learning and Teaching*, 6(1).

# Application of an IoT-Enabled Solar-Powered Microcontroller System for Preservation of Archived Materials in Libraries

Mohan Teja Mattigiri<sup>1</sup>, Nilufer Tamatgar<sup>2</sup> and Dr. Mahabaleshwara Rao<sup>3</sup>

<sup>1</sup> Research Scholar, <sup>3</sup> Associate Professor and Deputy Chief Librarian

<sup>1</sup>Dept. of Library and Information Science, Manipal Academy of Higher Education, India

<sup>2</sup>Dept. of Electrical and Electronics Engineering, Nanyang Technological University, Singapore

<sup>3</sup>Department of Library & Information Science and Health Sciences Library

Kasturba Medical College, Manipal Academy of Higher Education, Manipal, Karnataka, India  
E-mail: mohan.teja@learner.manipal.edu, nilufer001@e.ntu.edu, baikadi@yahoo.com; m.rao@manipal.edu

## Abstract

*The Internet of Things (IoT) is one example of how quickly emerging technologies find widespread use and increases their impact. Libraries house a wealth of information that is vital for academic pursuits. Libraries are now utilizing IoT to ensure the long-term viability of printed and archived materials and moving towards eco-friendly energy conservation methods like solar energy usage. It is important to prevent the print material from deteriorating or being spoilt. Mold and bio deterioration can flourish in unusually high or low-humidity environments, attracting unwanted pests. Traditional methods often fail to address the nuanced environmental conditions necessary for optimal preservation. By promoting IoT technologies, libraries can start a reliable system that continuously monitors and regulates temperature and humidity levels. Incorporating solar power as an energy source aligns with sustainable practices and ensures uninterrupted operation, critical for preserving materials over extended periods. The study focused on designing, implementing, and evaluating a solar power-sourced microcontroller system tailored to the unique requirements of non-air-conditioned library environments. By Amal gaming IoT and solar technology, this research aimed to contribute to developing cost-effective and eco-friendly solutions. Ultimately enhancing the preservation efforts of archived materials in libraries and safeguarding the documents for longer periods. The data that has been obtained is recorded on Google Sheets is analyzed for long-term statistics. Preventive measures are provided to the library staff to safeguard the materials during the fluctuations of parameters.*

**Keywords:** Emerging Technologies, Solar panel, Green Library, Temperature, Humidity Sensors, Microcontroller, Blynk-IoT, Google-IoT, SDG-7.

## Introduction

Library professionals face numerous challenges in safeguarding archival knowledge (Bakhshi, 2016). The rare documents and historical manuscripts are very fragile to be handled. The temperature and humidity fluctuations in the library add to the librarian's concerns (Kathpalia & Paris, 1973). The traditional methods of preservation of library materials come in handy, yet there is a need for innovative solutions to this query. The prospect of real-time monitoring and the user-friendly and adaptive nature of the Internet of Things (IoT) will transform traditional preservation strategies (Bansal *et al.*, 2018). IoT is responsive to controlling environmental parameters (Wulandari *et al.*, 2023).

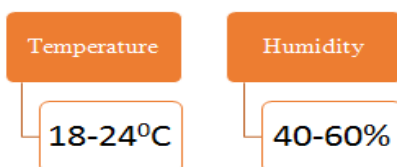

Fig.1 Ideal Temperature and Humidity Levels

The study focused mainly on selecting sensors for temperature and humidity, and suitable microcontrollers powered by solar energy for promoting sustainable practices in the library to preserve the archived materials in a library environment (Medina-Santiago *et al.*, 2020). The study explored the design and architecture of the hardware system set up to develop user-friendly interfaces for library professionals to deal with the challenges probed in archival management (Rahman *et al.*, 2020). Integrating the existing library infrastructure with minimal compatibility issues will benefit library professionals in operations and enhance preservation capability strategies using a sustainable approach to preserving archived materials (Sunny *et al.*, 2021). Fig.1 above depicts the ideal temperature and humidity levels for the libraries.

### **The Objectives of the Research**

1. To design and implement an IoT-enabled solar power-sourced system in libraries.
2. To ensure User-friendly interface and accessibility.
3. To investigate the library's temperature and relative humidity fluctuations to encourage long-term preservation of the print materials.

### **Literature Review**

#### *1. Traditional Archival Methods*

For years, traditional preservation methods have been used by libraries to safeguard documents (Bonang & Fitriyah, 2022). Although traditional methods like maintaining environmental conditions and following manual instructions have been effective to an extent (Kumar Dangi & Saraf, 2017). Solely depending on the conventional methods comes with challenges (Kumar, 2020). These challenges make libraries adopt emerging technologies (Asim *et al.*, 2022). To mitigate these challenges, exploring and integrating advanced technologies such as the Internet of Things (IoT) enhances the efficacy of preserving archived library materials (Kademani *et al.*, 2003). There is a need to bring awareness among librarians to adopt such technologies to tackle parameters such as temperature and humidity, which are foes to archived materials (Nasrin, 2021).

#### *2. IoT in Libraries*

The librarians have incorporated the Internet of Things in the libraries (Alvan Prastoyo Utomo *et al.*, 2019). In a short period, the IoT has taken over management functions to provide effective and enhanced services to library patrons. The application of IoT in libraries ranges from space utilization to smart technology incorporated digital tracking of resources (Kurniawan *et al.*, 2019) (Syahputra Novelan, 2020). The Internet of Things has enabled the implementation of technologies without compromising security and privacy. According to (Barik, 2019), IoT systems facilitate inventory control and seamless access to remote users, reducing the operational costs of providing the resources (Udrea *et al.*, 2020).

IoT implementation is user-friendly, extends its deployment to resource optimization, and integrates with other technologies like RFID to allow the automated circulation process (Khan *et al.*, 2022). Sensors like temperature and humidity have been instigated with Microcontrollers such as Raspberry Pi and ESP8266 to monitor indoor environments (Korotcenkov *et al.*, 2023) (Shete and Agarwal, 2016). The concept of smart libraries is possible with the emergence of IoT, which enables adaptive and personalized smart learning and Services such as security surveillance and access control systems (Xie *et al.*, 2019) (Pandey *et al.*, 2017).

### 3. Solar Power in Preservation

(Garcia-Fernandez & Omar, 2022) emphasized adopting environmentally friendly preservation methods and utilizing solar energy as a strategy is an eco-friendly method and climate responsive preservation. The solar-powered microcontrollers have been explored in various other sectors, such as agriculture, banks, etc., for the systems' feasibility (Hosman *et al.*, 2020). Solar power has benefited such as reduced operational costs and a more reliable power source for the long term (Ogo *et al.*, 2022) (Huaquipaco *et al.*, 2020). Solar energy is libraries is a sustainable energy solution in libraries that aids in mitigating environmental impacts and increases the life of archived materials by preserving them efficiently (Olu Adeyoyin *et al.*, 2019).

### 4. Temperature and Humidity Problems in Libraries

The well-being of the library collection depends on the critical maintenance of the environmental conditions (Jayewardeneperu, 2020). Fluctuations in the temperature and humidity in libraries can lead to a potential acceleration of deterioration of printed materials. There are ideal temperatures and humidity levels that need to be maintained in the library. There are no set standards for individual libraries, but physical degradation and growth of mold can be prevented by maintaining ideal temperature and humidity levels (Hayleeyesus & Manaye, 2014) (Hashim *et al.*, 2019). Optimal conditions must be maintained to preserve the library's archived materials long-term. Many challenges are involved in maintaining the parameters in the library, and necessary adaptive strategies must be maintained to ensure sustained protection of archived materials in the library (Mubofu and Mambo, 2020).

## Methodology

The methodology is divided into 2 phases. In the primary phase, the design and architecture of the system included the selection of appropriate sensors for temperature and humidity. Followed by the selection of a microcontroller which is solar energy dependent. After the design and architecture phase, hardware implementation involves assembling selected sensors, integrating microcontrollers, and configuring solar power components.

Further, software components will be integrated to facilitate data processing in real-time. Subsequently, a user-friendly interface for monitoring and control will be selected.

Based on repeated performance evaluation testing and comprehensive cost efficiency, sustainability benefits are considered and ideal components to maintain optimum environmental conditions are selected. The final step includes integrating the existing library setup without hindering the library operations.

Here is the list of the essential hardware components:

1. Solar Panel
2. Microcontroller
3. Wi-Fi
4. Sensors

The open-source software tools that can be utilized are:

1. Arduino IDE/ Visual Studio
2. Blynk IoT/ Google cloud IoT
3. Google Sheets



### Implementation of the Process

The prototype for the IoT application in the library is implemented using the temperature and relative humidity sensor. The sensor transmits the real-time analog data to the microcontroller that is powered by the solar panels. The microcontroller has an inbuilt Wi-Fi that transfers the data to the cloud platform and the Google Sheets. The visual indication to understand whether the temperature and humidity values have crossed the optimum range is obtained via LEDs that are connected to the microcontroller. The circuit diagram is shown in Fig.2. The steps that are taken include Data collection, processing, storage, and analysis.

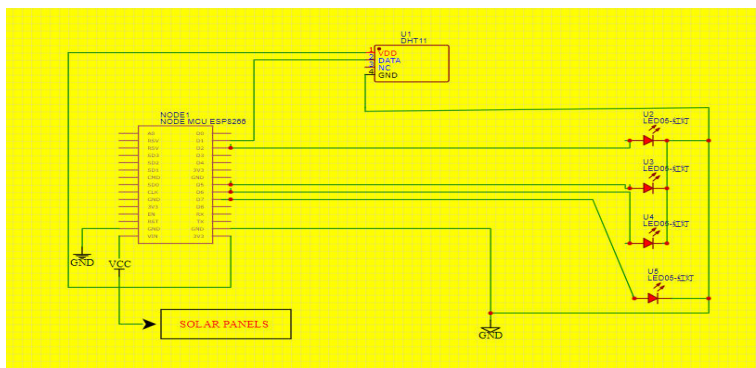

Fig.2 Schematic Circuit Diagram

### Data Collection

Data generated using a humidity and temperature sensor (DHT11) is continuously sent to the microcontroller. The microcontroller further processes the data and the code specific to the library's requirements is written on the Arduino IDE.

### Processing of the Data

The temperature and humidity data are sent to the cloud platform via Wi-Fi. The IoT application will display the real time temperature and humidity values and intimidate the person monitoring the system if the temperature or humidity values exceed the optimum range. The message received by the application will advise about the preventive steps that must be performed to avoid damage to the print material caused by temperature and humidity fluctuations. The alert warning and a link to the necessary preventive steps are also emailed to the librarian. The data is also sent to Google Sheets every hour to track temperature and humidity variations over time. Fig.3 displays the notification and reading on the mobile application and the web browser.

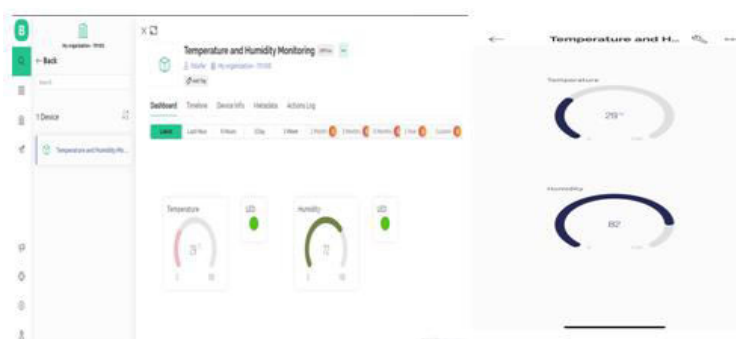

Fig.3 Notification of Temperature and Humidity on Blynk IoT

### Data Storage

Given the importance of print items in libraries, such as archival papers, journals, textbooks, and periodicals, it is critical to preserve them. Temperature and humidity are important factors in keeping the print material in optimum condition. The data is stored in Google Sheets and is utilized to comprehensively analyze the temperature and humidity fluctuations in the non-air conditioned library. Fig.4 shows the real-time recordings of temperature and humidity.

	A	B	C	D	E
	Date	Time	Temperature( Celsius)	Humidity (%)	
1					
2	01/10/2023	00:00:00	26.42	81.82	
3	01/10/2023	01:00:00	23.64	87.9	
4	01/10/2023	02:00:00	24.64	84.9	
5	01/10/2023	03:00:00	27.57	80.78	
6	01/10/2023	04:00:00	26.36	88.99	
7	01/10/2023	05:00:00	27.03	79.25	
8	01/10/2023	06:00:00	29.66	86.67	
9	01/10/2023	07:00:00	29.14	86.33	
10	01/10/2023	08:00:00	27.92	83.98	
11	01/10/2023	09:00:00	24	82.79	
12	01/10/2023	10:00:00	25.28	80.61	
13	01/10/2023	11:00:00	23.44	82.67	
14	01/10/2023	12:00:00	29.29	86.23	
15	01/10/2023	13:00:00	25.01	79.3	
16	01/10/2023	14:00:00	24.73	85.99	
17	01/10/2023	15:00:00	23.92	80.17	
18	01/10/2023	16:00:00	29.94	80.26	
19	01/10/2023	17:00:00	24.64	80.11	
20	01/10/2023	18:00:00	27.94	82.52	
21	01/10/2023	19:00:00	23.31	79.13	
22	01/10/2023	20:00:00	24.43	79.91	

Fig. 4 Google Sheet Realtime Recording

The data logging can help establish a broad understanding of the variations in temperature and humidity in the libraries across the various seasons of the year. The device is placed near the bookshelf to record the values. Fig.5 depicts the summary of the implementation process.

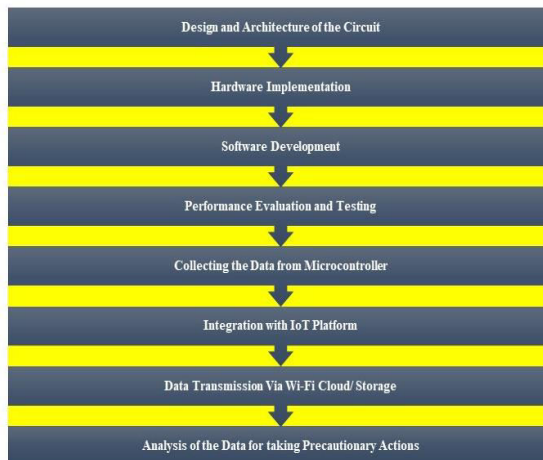

Fig.5 Summary of the Implementation Process

### Simulation Results and Discussion

The Temperature and Relative Humidity Data Logs Collected in Google Sheets during the winter season for the month of October, November, and December were transferred into an Excel sheet for analysis. Temperature and relative humidity readings were recorded every hour, and the average temperature and humidity values for each day were plotted for the span of three months. Fig.6 depicts the graphical representation of the collected data.

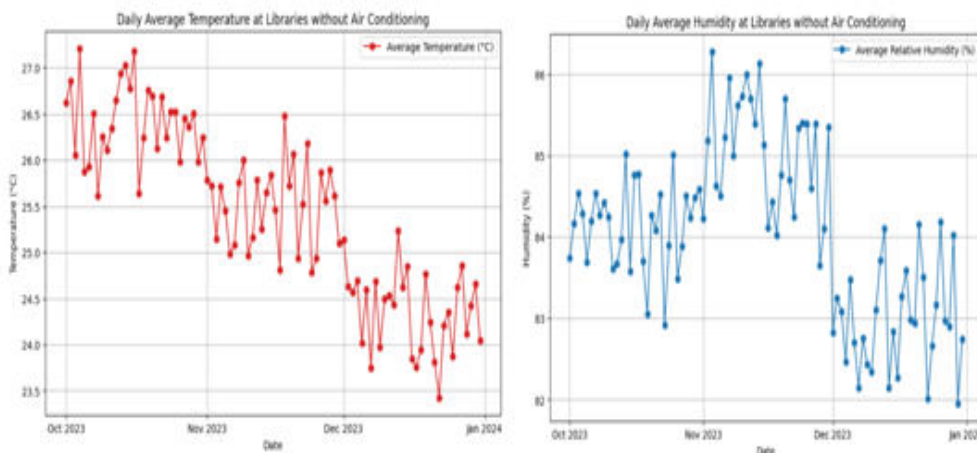

Fig.6 Average Temperature and Relative Humidity plotted over three months

The analysis shows that the daily average temperature values fluctuate between 23.5- 27.0 degrees Celsius, while the optimum temperature for maintaining good health of the books is  $(18-24)^0$  C. The daily average relative humidity values fluctuate between 81%-87%, which is greater than the optimum range required, i.e., 40%-60%.

Importance of Temperature and Humidity in maintaining archive materials:

1. High temperatures promote physical deterioration of archive materials (Gallo, 1961).
2. High relative humidity causes damaging chemical reactions.
3. High humidity and low temperatures promote mold and bug growth.
4. Extreme warmth and humidity can cause paper cockling, ink flaking, bent book covers, and fractured emulsions (Ratri Noor Wulandari *et al.*, 2020).

Data analysis can provide libraries to develop preventative standards. Temperature and humidity might be above or below optimal. Preventive interventions, listed in the table below, may assist in maintaining optimal levels in such instances. Table I describes high- and low-temperature and humidity control, (Sahoo, 2004) (Adcock, 1993).

The ideas are some methods that may be used to prevent and protect print materials within the parameters of the library environment. Blynk IoT presents the preventative measures that need to be followed as a popup message, and the person in authority is informed of the preventive activities that need to be implemented. When these procedures are followed, the archived materials in the library will be able to be preserved for a longer length of time (Fu, 2021).

TABLE I MEASURES TO MAINTAIN OPTIMAL TEMPERATURE AND HUMIDITY

Control High Temperature	Control Low Temperature
Implement a comprehensive temperature monitoring system. Monitoring allows for quick identification of temperature increase	Ensure the library's heating system is in good working condition and maintains a consistent temperature. Regular maintenance is essential to prevent malfunctions during cold periods
Strategically place throughout the library	Implement a temperature zoning system to direct heat to typically colder areas with sensitive materials. This allows for targeted heating where it is most needed.
Enhance the insulation of the library building to minimize the impact of external high temperatures.	Improve the insulation of the library to minimize heat loss. Insulated windows, doors, and walls prevent cold air infiltration and maintain a stable indoor temperature.
Install window treatments, such as blinds or shades, to control the amount of sunlight entering the library	Install weather stripping around doors and windows to seal gaps and prevent drafts. This helps to keep the cold air out and maintains a warmer interior
Control High humidity	Control Low humidity
Install humidity monitoring systems throughout the library to continuously track and measure humidity levels. This allows for early detection of fluctuations and timely intervention	Invest in quality humidification systems to add moisture to the air when necessary. These systems can be strategically placed to target specific areas with lower humidity
Invest in high-quality dehumidification systems to actively remove excess moisture from the air	Identify and seal any leaks or gaps in the library's structure that may allow dry air to enter. This helps in maintaining a controlled and consistent indoor environment
Ensure that the library's HVAC system is set to maintain optimal humidity levels	Utilize storage materials, such as metal or sealed wood, that resist moisture absorption. Consider using sealed storage containers for sensitive items to protect them from low humidity.
Identify and seal any leaks or gaps in the library's structure that may allow humid air to enter	Use humidity-regulating storage solutions, such as microclimate enclosures or storage cabinets with humidity controls

## Conclusion

There is no doubt that additional research and case studies will contribute to the refinement of best practices and the maximization of the benefits of this novel approach to library preservation as libraries continue to adopt Internet of Things (IoT) technological solutions. The research facilitates various applications, including collecting real-time data, which is used to identify deviations from ideal environmental conditions and enable prompt action. Being physically present to keep track of the needs is a hardship that can be reduced through the use of remote monitoring. It is possible to store the data that has been recorded, which will help with the analysis of long-term planning for environmental control. Energy efficiency optimizes resource allocation by concentrating on the areas that demand immediate attention. This is accomplished by minimizing energy use during periods of stability. Using solar panels as an energy source is a one-time investment and promotes the concept of a green library with sustainable goals.

## References

- [1] Adcock, E. P. (1993). IFLA Principles for the Care and Handling of Library Material International Federation of Library Associations and Institutions Core Programme on Preservation and Conservation and Council on Library and Information Resources International Preservation Issues Number One 2 Acknowledgements. In International Preservation Issues Number One (Vol. 1).
- [2] Alvan Prastoyo Utomo, M., Aziz, A., Winarno, & Harjito, B. (2019). Server Room Temperature & Humidity Monitoring Based on Internet of Thing (IoT). *Journal of Physics: Conference Series*, 1306(1). <https://doi.org/10.1088/1742-6596/1306/1/012030>
- [3] Asim, M., Arif, M., & Rafiq, M. (2022). Applications of Internet of Things in university libraries of Pakistan: An empirical investigation. *Journal of Academic Librarianship*, 48(6). <https://doi.org/10.1016/j.acalib.2022.102613>

- [4] Bakhshi, S. I. (2016). Digitization and Digital Preservation of Cultural Heritage in India with Special Reference to IGNCA, New Delhi. In *Asian Journal of Information Science and Technology* (Vol. 6, Issue 2). [www.trp.org.in](http://www.trp.org.in)
- [5] Bansal, A., Arora, D., & Suri, A. (2018). Internet of Things: Beginning of New Era for Libraries. <http://digitalcommons.unl.edu/libphilprac/2081>
- [6] Barik. (2019). IoT based Temperature and Humidity Controlling using Arduino and Raspberry Pi. *Robotics (IJACSA) International Journal of Advanced Computer Science and Applications*, 10(9). [www.ijacsa.thesai.org](http://www.ijacsa.thesai.org)
- [7] Bonang, D., & Fitriyah, A. T. (2022). Bayan Traditional Library as the Source of Information, Education, and Cultural Preservation. *Khizanah Al-Hikmah: Jurnal Ilmu Perpustakaan, Informasi, Dan Kearsipan*, 10(1), 36–45. <https://doi.org/10.24252/kah.v10i1a4>
- [8] Fu, X. (2021b). Research on Long Term Preservation Strategy of University Library's Books and Materials Based on Internet of Things Data. *Journal of Physics: Conference Series*, 1992(3). <https://doi.org/10.1088/1742-6596/1992/3/032045>
- [9] Gallo, F. (1961). Biological agents which damage paper materials in libraries and archives. *Studies in Conservation*, 6, 55–61. <https://doi.org/10.1179/sic.1961.s015>
- [10] Garcia-Fernandez, B., & Omar, O. (2022). Integrated innovative solar lighting system for optimization of daylight utilization for public library in Alexandria, Egypt. *Ain Shams Engineering Journal*. <https://doi.org/10.1016/j.asej.2022.101819>
- [11] Hashim, F., Mohamad, R., Kassim, M., Suliman, S. I., Anas, N. M., & Bakar, A. Z. A. (2019). Implementation of embedded real-time monitoring temperature and humidity system. *Indonesian Journal of Electrical Engineering and Computer Science*, 16(1), 184–190. <https://doi.org/10.11591/ijeecs.v16.i1.pp184-190>
- [12] Hayleeyesus, S. F., & Manaye, A. M. (2014). Microbiological quality of indoor air in University libraries. *Asian Pacific Journal of Tropical Biomedicine*, 4, S312–S317. <https://doi.org/10.12980/APJTB.4.2014C807>
- [13] Hosman, L., Gómez Zermeño, M. G., & de la Garza, L. A. (2020). Solar SPELL assessment: Impact of a solar-powered digital library as a teaching-learning resource on climate change. *Sustainability (Switzerland)*, 12(16). <https://doi.org/10.3390/su12166636>
- [14] Huaquipaco, S., Beltran, N., Sarmiento, V., Pizarro, H., Cruz, J., Condori, R., Cutipa, J. R., Romero, C., & Achahuanco, N. (2020). Solar library. *Proceedings of the ISES Solar World Congress 2019 and IEA SHC International Conference on Solar Heating and Cooling for Buildings and Industry 2019*, 2507–2513. <https://doi.org/10.18086/swc.2019.52.01>
- [15] Jayewardeneperu, S. (2020). Identification of the factors that deteriorated historically valuable library resources (Library of the University of Sri Jayewardeneperu and the Library of the Department of National Museum). *IOSR Journal Of Humanities And Social Science (IOSR-JHSS)*, 25(1), 07–10. <https://doi.org/10.9790/0837-2501090710>
- [16] Kademani, B. S., Kalyane, V. L., & Kumar, V. (2003b). BOSALA One Day Seminar: Resource Management 2003 Preservation of Information Resources in Libraries: New Challenges.
- [17] Kathpalia, Y. P., & Paris, U. (1973). Conservation and restoration of archive materials.
- [18] Khan, A. U., Zhang, Z., Chohan, S. R., & Rafique, W. (2022). Factors fostering the success of IoT services in academic libraries: a study built to enhance the library performance. *Library Hi Tech*, 40(6), 1976–1995. <https://doi.org/10.1108/LHT-06-2021-0179>
- [19] Korotcenkov, G., Simonenko, N. P., Simonenko, E. P., Sysoev, V. V., & Brinzari, V. (2023). Paper-Based Humidity Sensors as Promising Flexible Devices, State of the Art, Part 2: Humidity-Sensor Performances. In *Nano materials* (Vol. 13, Issue 8). MDPI. <https://doi.org/10.3390/nano13081381>

- [20] Kumar Dangi, R., & Saraf, S. (2017). Role of Libraries in Preservation of Traditional Knowledge: with Special Reference to India. *Qualitative and Quantitative Methods in Libraries (QQML)*, 6, 35–42. [www.ignca.nic.in](http://www.ignca.nic.in)
- [21] Kumar, S. (2020). Application of Conservation and Preservation Techniques to Enhance the Life of Traditional and Digital Information Resources in Libraries. *DESIDOC Journal of Library & Information Technology*, 40(3), 147–152. <https://doi.org/10.14429/djlit.40.3.15688>
- [22] Kurniawan, D. E., Iqbal, M., Friadi, J., Borman, R. I., & Rinaldi, R. (2019). Smart Monitoring Temperature and Humidity of the Room Server Using Raspberry Pi and Whatsapp Notifications. *Journal of Physics: Conference Series*, 1351(1). <https://doi.org/10.1088/1742-6596/1351/1/012006>
- [23] Medina-Santiago, A., Azucena, A. D. P., Gomez-Zea, J. M., Jesus-Magana, J. A., De La Luz Valdez-Ramos, M., Sosa-Silva, E., & Falcon-Perez, F. (2020). Adaptive Model IoT for Monitoring in Data Centers. *IEEE Access*, 8, 5622–5634. <https://doi.org/10.1109/ACCESS.2019.2963061>
- [24] Mubofu and Mambo. (2020). 2020\_Mubofu\_Academic Libraries and Information Resources Preservation Strategies-Past, Present and the Way Forward. *Covenant Journal of Library and Information Science*, 3(1).
- [25] Nasrin, S. (2021). International Journal of Current Science Research and Review Agents of Deterioration of Organic Museum Objects and Their Management: A Review. *International Journal of Current Science Research and Review*, 4(9). <https://doi.org/10.47191/ijcsrr/V4-i9-04>
- [26] Ogo, E. P., Omosekejimi, A. F., & Ebhonu, S. I. (2022). Usage of Solar Inverter Technology as Alternative Energy Source: A Catalyst for Round the Clock Electronic Services in Nigerian University Libraries. *Information Impact: Journal of Information and Knowledge Management*, 12(2), 113–125. <https://doi.org/10.4314/ijikm.v12i2.9>
- [27] Olu Adeyoyin, S., Kehinde Alawiye, M., Ruth Ewulo, O., Olu, S., Kehinde, M., & Ruth, O. (2019). Awareness and Use of Solar Energy as Alternative Power Source for ICT Facilities in Nigerian University Libraries and Information Centres. <https://digitalcommons.unl.edu/libphilprac>
- [28] Pandey, J., Imran, S., Kazmi, A., Hayat, M. S., & Ahmed, I. (2017). A Study on Implementation of Smart Library Systems using IoT.
- [29] Rahman, R. A., Hashim, U. R., & Ahmad, S. (2020). IoT-based temperature and humidity monitoring framework. *Bulletin of Electrical Engineering and Informatics*, 9(1), 229–237. <https://doi.org/10.11591/eei.v9i1.1557>
- [30] Ratri Noor Wulandari, E., Malik Abdullah, H., Rosyida, N., Dewa Made Widia, I., & Khusnul Fatimah, N. (2020). The Effect of Temperature and Relative Humidity On the Collection Preservation Index (PI) at the Main Library of Brawijaya University. In *International Journal of Latest Research in Humanities and Social Science (IJLRHSS)* (Vol. 03). [www.ijlrhss.com](http://www.ijlrhss.com)||PP.01-06www.ijlrhss.com
- [31] Sahoo, J. (2004). Preservation of Library Materials: Some Preventive Measures. In *OHRJ: Vol. XLVII* (Issue 1).
- [32] Shete and Agarwal. (2016). *IoT Based Urban Climate Monitoring using Raspberry Pi*.
- [33] Sunny, A. I., Zhao, A., Li, L., & Kanteh Sakiliba, S. (2021). Low-cost IoT-based sensor system: A case study on harsh environmental monitoring. *Sensors (Switzerland)*, 21(1), 1–12. <https://doi.org/10.3390/s21010214>
- [34] Syahputra Novelan, M. (2020). Monitoring System for Temperature and Humidity Measurement with DHT11 Sensor Using Node MCU. In *International Journal of Innovative Science and Research Technology* (Vol. 5, Issue 10). [www.ijisrt.com](http://www.ijisrt.com)123

- [35] Udrea, I., Gheorghe, V. I., Cartal, L. A., Duminica, D., Petrache, S., Apostolescu, T. C., & Kraus, V. F. (2020). IoT solution for monitoring indoor climate parameters in open space offices. *E3S Web of Conferences*, 180. <https://doi.org/10.1051/e3sconf/202018002012>
- [36] Wulandari, E. R. N., Abdullah, H. M., & Asri, T. M. (2023). Internet of Things (IoT) Based Temperature and Humidity Monitoring System for Library Rooms (pp. 235–241). [https://doi.org/10.2991/978-94-6463-140-1\\_23](https://doi.org/10.2991/978-94-6463-140-1_23)
- [37] Xie, Y., Liu, J., Zhu, S., Chong, D., Shi, H., & Chen, Y. (2019). An IoT-based risk warning system for smart libraries. *Library Hi Tech*, 37(4), 918–932. <https://doi.org/10.1108/LHT-11-2017-0254>

# Revolutionizing Libraries with RFID, Biometric Gates and Self-Service Kiosks

Renald Moses<sup>1</sup>, Rohini Manikandan<sup>2</sup> and Anneruth<sup>3</sup>

<sup>1</sup>Assistant librarian, <sup>2&3</sup>Librarian

<sup>1</sup>De Montfort University Dubai, Dubai International Academic City, Dubai, UAE

<sup>2</sup>Rajam Krishnamurthy Public School, Tiruchirappalli, Tamil Nadu, India

<sup>3</sup>Apollo institute of Allied Sciences and Hospital Management, Tamil Nadu, India

E-mail: Renaldstark@gmail.com, Rohini1701k@gmail.com, Anneruth5543@gmail.com

## Abstract

*Libraries are evolving, embracing modernization and digitization to meet user expectations. This article explores the integration of advanced technologies reshaping library environments, from sophisticated anti-theft measures and biometric identification to self-checkout kiosks. These innovations enhance resource protection, streamline entry, and empower users in managing borrowing. Recognizing the pivotal role of lighting, libraries invest in cutting-edge solutions to create inviting spaces for reading and research. This comprehensive approach reflects a commitment to providing a contemporary and user-friendly environment. As libraries transform into dynamic information hubs, adopting these advancements becomes a strategic move to stay relevant, catering to tech-savvy users while fostering exploration and learning in the digital age.*

**Keywords:** Libraries, Modernization of Library, Anti-theft measures, Self-checkout kiosks, Library security systems, Library turnstiles, Global infrastructure, Network environments, Library automation, Digitization.

## Introduction

In an era of tech-driven transformation, libraries are shedding their traditional image to emerge as dynamic hubs tailored to meet the evolving needs of users. No longer confined by outdated norms, modern libraries are embracing cutting-edge technologies to redefine user experiences and operational efficiency. This article explores the integration of advanced solutions, marking a departure from the ordinary. From sophisticated anti-theft tech to user-friendly self-checkout kiosks, libraries are not just securing resources but enhancing accessibility and convenience. Beyond security, lighting takes center stage, creating an inviting space for reading and research. Modern libraries are investing in state-of-the-art lighting solutions to ensure an atmosphere that is both secure and visually appealing. As libraries aspire to attain international acclaim, this commitment to technology integration and facility enhancement becomes pivotal. It's a conscious effort to catapult our libraries into a realm of global excellence, redefining standards worldwide. By embracing innovation and reimagining traditions, our libraries are set to transcend boundaries, offering a transformative global experience. This journey is not just a pursuit of modernity but a dedicated endeavor to position our libraries at the forefront of innovation, accessibility, and knowledge dissemination—becoming beacons of inspiration for libraries around the world.

## Library Automation

Library automation involves utilizing computers to streamline typical library tasks like cataloging and circulation. Computers and technology support a library's systems and services throughout the automation process. This conversion from manual to computerized operations includes transitions such as moving from card catalogs to Online Public Access Catalogs (OPAC) or shifting from manual circulation cards to integrated library systems. Automation employs machinery to simplify work, conserving human effort and time. The primary objective is to liberate librarians and staff, enabling more effective contributions to knowledge dissemination. In Library Science, automation



is defined as the technology focused on designing processes and systems to minimize human intervention in their operation.

The inception of automation dates to the 1960s with the introduction of machine-readable catalogue records (MARC). Over time, automation has expanded to cover essential activities like acquisitions, cataloging, authority control, serials control, circulation and inventory, interlibrary loan, and document delivery. Contemporary developments include the growing importance of "add-ons" related to the distribution of digital materials, such as link resolvers, portal and metasearch interfaces, and e-resource management modules provided by external vendors, indicating a heightened integration with the Web domain.

### **RFID and its Essential for the Library**

RFID, or Radio-Frequency Identification, has two parts: a tag and a reader. The tag encodes information, and the reader accesses and transmits it. In libraries, RFID tags are passive and powered by the reader. Libraries use RFID for circulation, security, and automated systems. RFID improves efficiency, allowing staff to focus on user services. Despite budget constraints, RFID provides a quick return on investment, protecting the collection and enhancing community value. It's user-friendly, ensuring a satisfying experience for both staff and users, including children.

RFID now refers to techniques for using RFID tags to track and trace goods both domestically and globally. RFID is among the several technologies utilized in "auto-ID procedures," which refer to techniques for mechanically recognizing items. RFID alone isn't a location-tracking technology. Where readings have been placed, RFID may be used to track tagged things. However, this static readership is not the same as systems like global positioning system, or GPS, which use a network of satellites to establish the location of every receiver. The degree to which an RFID application will fulfil its primary functionality depends on several important factors.

1. Durable
2. Broad Data-Capacity Spectrum
3. Contactless
4. Line-of-sight obstruction
5. Writeable Data
6. Support for Various Tag Readings

### **Challenges to Implementation RFID Technology in Libraries**

1. The Accessibility of resource
2. Worldwide Standards
3. Administration's Commitment
4. choosing a tag and tag reader
5. Data Management

### **Libraries' Safety and Security: Opportunities and Challenges**

Three things make up a library: documents, users, and employees. Providing this triad with a safe and secure environment is the aim of library security systems. Threats come from both natural and artificial sources. Among the most well-known security methods include RFID, locks, turnstiles, safes, demand alarms, security lights, closed circuit TVs, and professional employees. The newest technology, RFID, is being implemented in several libraries. RFID is widely used because it offers many benefits, despite some research claiming it poses health risks. A modern library is also a repository for digital information, which means that digital data must also be protected.

### **RFID Security Gate**

One essential instrument to stop books from being taken outside of the library is the RFID security gate. It is possible to connect this intelligent gate system to a variety of gadgets, including People Counter Sensors, CCTV cameras, and door locks. RFID tags are attached to every library book to guarantee efficient use. The security gate sounds an alarm and notifies the librarians when a patron tries to leave the library with a book that is not authorized. The gate further enhances overall security measures by facilitating the tracking of consumers' in-out entries using HF/UHF tags.



Fig.1 Library RFID Security Gate

### **Functions of Library RFID Security Gate**

1. The RFID Security Gate reads the RFID-tagged objects that customers take with them as they exit the library.
2. The barrier sounds an alert to stop unwanted removal whenever it detects an unauthorized book.
3. It may also use RFID tags to track the entries made by customers.

### **Highlight Features**

1. Security alarm to prevent the exit of unauthorized books.
2. Can be integrated with Webcam.
3. HF, UHF, EM, and Hybrid (RFID and EM) configurations available .
4. UPS support with a minimum backup time of 4 hours.
5. Complete 3D Protection.
6. People Counter Module.
7. Database Integration.
8. Library Management System Integration.

### **Library Turnstiles**

To provide the highest degree of security and entrance control, library access control systems need physical access control products. Turnstiles at libraries and ADA-accessible gates take admittance to a new level by serving as physical obstacles to entry and automatically verifying credentials, such as library cards.

## Types of Turnstiles



Fig.2 Turnstile



Fig.3 Using Turnstile at the library photograph.

### Remote Access of Library Resources

Remote access to library resources is crucial for flexibility and convenience, allowing users to access information from any location around the clock. This accessibility caters to diverse schedules and users globally, fostering collaboration, aiding in emergency preparedness, and aligning with contemporary learning environments. Ultimately, it enhances the significance and applicability of library services in our digital era.

### Remote Access and Methods

The capacity to access a computer, server, or other device remotely over a network connection is known as remote access. Users can operate remotely from home or outside the office as long as they have access to a distant computer or network. The same idea applies to library data, which may be accessed remotely using a server or cloud login. Twenty years ago, accessing the library resource was a routine job. Direct (physical) lines, virtual private networks, Microsoft Remote Desktop Services, and other techniques including wireless networks, DSL (digital subscriber lines), cable modems, as well as combined service digital networks were used at the time to accomplish remote access. Other options include URL rewriting proxy, EZ proxy, and proxy servers. EZ Proxy is still up and running with ongoing services.

### Library Usage during Covid-19

The Covid-19 epidemic has had a significant negative effect on Ph.D. candidates and students, disrupting their studies and making it difficult for them to get resources. Seeing this, libraries are

now forced to change how they offer services to meet the demands of students throughout the globe by giving them complete remote access to databases and information resources. Libraries need to change to become more contemporary organizations that excel in providing remote access services in response to the present environment. To satisfy the needs of a dynamic, digitally driven academic environment where accessibility and flexibility are critical, this transition is imperative. Building a global infrastructure for remote access should be a top priority so that scholars and students may easily access a multitude of data from any location in the globe. This entails putting in place cutting-edge digital platforms, databases, and tools that make it easier to find, retrieve, and use academic information quickly. In order to ensure that students can effortlessly access and explore the wide range of resources available, modern libraries should make use of technology to build interfaces that are easy to use. Furthermore, it is imperative to prioritize the provision of remote assistance and support services, which guarantee consumers receive real-time advice and assistance regardless of their location.

Working together with publishers, universities, and organizations globally becomes essential to improving the library's digital resource collection and making ensuring it continues to be relevant to the various requirements of academics and students throughout the world. This cooperative endeavor might entail taking part in global consortiums, exchanging resources, and collaborating on projects that encourage the unrestricted exchange of information across nations. Moreover, it takes a dedication to ongoing innovation to keep up with changing consumer demands and technological advancements. In order to modify their services in response to patrons' changing needs and preferences, libraries should aggressively seek out customer input. Maintaining current knowledge of cutting-edge technology, such machine learning and artificial intelligence, is necessary to improve the efficacy and efficiency of remote access services. Essentially, the conversion of libraries into updated, globally reachable information centers is a necessary reaction to the difficulties presented by the Covid-19 epidemic. No matter where they are physically located, libraries may be a vital source of support for students' and researchers' academic endeavors by emphasizing remote access services and adopting a global viewpoint.

### **Unlocking Connectivity: The Essentials of Remote Access in Network Environments**

1. To put it simply, remote access is the capacity to connect to a computer or server remotely over a network.
2. Users can work remotely from home or outside the workplace and yet have a link to a remote computer or system.
3. Virtual Private Networks (VPNs), Wide Area Networks (WANs), and Local Area Networks (LANs) may all benefit from remote access.

### **Types of Remote Access**

1. Direct line.
2. Virtual private line.
3. Microsoft Remote Desktop Services.
4. Other methods include Integrated Service Digital Network, Wireless Network, DSL- Digital Subscriber Line, Cable Modem etc.

### **Self-Service Kiosks**

Transforming conventional library services, a contemporary library kiosk system becomes a dynamic tool for patrons, facilitating easy book rentals, efficient loan fine payments, and streamlined book acquisition processes. By replacing paper-based transactions, the kiosk offers a modern solution for users to effortlessly explore the latest collection additions, manage borrowed books, and provide feedback on their reading experiences. In educational settings like schools and

universities, the library kiosk gains added significance. Beyond simplifying transactions, it actively engages students, hosts a vast repository of resources, and ensures effective inventory management—a crucial feature for a forward-looking upgrade in today's digital libraries.



Fig.4 A Self-Service Kiosk Placed in the Library for the Use of Library Users.

### **Advantages of Implementing Self-Service Kiosks in Libraries**

1. *Efficient Self-Service:* Kiosks empower library users to independently handle tasks like borrowing, returning, and managing their accounts, streamlining library processes.
2. *24/7 Accessibility:* Self-service kiosks extend library services beyond regular hours, allowing patrons to access resources, borrow or return items at their convenience.
3. *Quick Transactions:* Kiosks facilitate swift transactions, enabling patrons to borrow or return books promptly, especially during busy periods.
4. *Privacy and Autonomy:* Kiosks provide a level of privacy and independence for patrons who prefer to manage routine tasks without staff interaction.
5. *Multifunctional Capabilities:* Kiosks can offer diverse services beyond check-in/check-out, enhancing the overall functionality of the library.
6. *User-Friendly Interface:* Modern kiosks feature user-friendly interfaces, making them accessible to a broad range of patrons, including those unfamiliar with traditional library processes.
7. *Cost-Effective:* While there's an initial investment, kiosks can lead to long-term cost savings by reducing the need for additional staff and optimizing resource management.
8. *Reduced Workload for Staff:* Automating routine tasks through kiosks allows library staff to focus on more complex inquiries, improving overall productivity.
9. *Enhanced Accessibility:* Kiosks can be designed with accessibility features, ensuring they cater to users with diverse needs, including those with disabilities.
10. *Data Collection and Analytics:* Kiosks collect valuable data on library usage patterns, aiding libraries in making informed decisions about resource allocation and service improvements based on user preferences.

### **Conclusion**

In conclusion, the imperative to revolutionize libraries through the integration of advanced technologies like RFID, biometric gates, remote access, and self-service kiosks cannot be overstated. These innovations, collectively enhancing operational efficiency and patron services, represent a crucial step towards aligning libraries with the demands of the modern era. By incorporating automation, RFID technology, and biometric gates, libraries not only bolster security and inventory management but also elevate user experiences. The global accessibility facilitated by remote access meets the diverse needs of a digitally connected audience, while self-service

kiosks empower patrons with efficient and user-friendly interactions. This transformative journey positions libraries as dynamic information hubs, fostering exploration, learning, and accessibility in the digital age. Moreover, it is a strategic imperative to propel our libraries into visionary and international-level developments, ensuring they stand at the forefront of innovation, knowledge dissemination, and community engagement on a global scale. Embracing these technologies is not just about modernization; it is about realizing a vision where our libraries become beacons of inspiration and excellence in the international library landscape.

## References

- [1] *Databases List*. (n.d.). Umb.libguides.com. Retrieved January 25, 2024, from <https://umb.libguides.com/az.php?t=12752>
- [2] [https://library.iitd.ac.in/arpit\\_2020-2021/Week%206%20-%20Module%2015%20-%20PPT-%20Remote%20Access%20to%20E-Resources%20Anywhere,%20Anytime.pdf](https://library.iitd.ac.in/arpit_2020-2021/Week%206%20-%20Module%2015%20-%20PPT-%20Remote%20Access%20to%20E-Resources%20Anywhere,%20Anytime.pdf)
- [3] *Library Automation*. (n.d.). <https://www.librarianshipstudies.com/2017/10/library-automation.html>
- [4] *Library RFID Security gate*. (2023, January 31). <https://2cqr.in/library-rfid-security-gate/>
- [5] *library turnstiles* | *MairsTurnstile.com*. (n.d.). Retrieved January 25, 2024, from [https://mairsturnstile.com/tag/library-turnstiles\\_](https://mairsturnstile.com/tag/library-turnstiles_)
- [6] *Library Turnstiles and ADA Gates* | Automatically Process Library Cards. (n.d.). Hayward Turnstiles. Retrieved January 25, 2024, from <https://www.haywardturnstiles.com/category/library-turnstiles-gates/#:~:text=Most%20libraries%20either%20use%20waist>.
- [7] Raghavaiah, P & Karnati, Srikanth. (2022). *Remote Access to Academic Libraries using Online Platforms in India: A Comprehensive Study*.
- [8] *RFID In Libraries: Should Libraries Invest In RFID?* (2018, August 21). [www.bibliotheca.com](http://www.bibliotheca.com). <https://www.bibliotheca.com/rfid-in-libraries-technology-that-helps-extend-impact/>
- [9] Singh, N. K., & Mahajan, P. (2014). *Application of RFID technology in libraries. International Journal of Library and Information Studies*, 4(2),1-9.

# Roles of Information and Communication Technology (ICT) in Knowledge Management (KM) at Nigerian Higher Institutions

Muhammad Muhammad Suleiman<sup>1</sup>, Abubakar Ukashatu<sup>2</sup>,  
Bilkisu Gambo Danmuchikwali<sup>3</sup>, Yusuf Auwalu<sup>4</sup> and Ali Muhammad Sulaiman<sup>5</sup>

<sup>1</sup>Alumni School of Computer Application, Lovely Professional University, Punjab, India

<sup>2,3&4</sup>Kano State Polytechnic, Kano, Nigeria

<sup>5</sup>Department of Library and Information Science, Bayero University, Kano, Nigeria

E-mail: muhddkd@gmail.com

## Abstract

*Technology is quickly developing these days. Technology is an integral part of any organisation and our daily lives. The education sector benefits from information and communication technology since it facilitates efficient knowledge management procedures and applications. The use of ICT in knowledge management (KM) has highlighted the urgent need for new approaches, instruments, and strategies in the creation of knowledge processes, knowledge technologies, and KM systems frameworks to support efficient knowledge management and better service delivery in higher education. Institutions of higher learning in Nigeria that want to thrive in KM must make an effort to successfully connect KM initiatives and procedures with their dynamic demands to achieve their objectives. To ensure that ICT is successfully used in knowledge management, addressing these issues requires a new conceptual framework and an expanded research agenda. Researchers in the fields of technology, education, and knowledge management may find value in the findings. The purpose of this study is to examine the role of ICT in higher education's knowledge dissemination and utilisation processes.*

**Keywords:** ICT, Knowledge Management, Higher Institutions, Library, Knowledge Sharing

## Introduction

Information comes from data, just as knowledge comes from information. The majority of the labour must be done by humans if information is to become knowledge (Davenport & Prusak, 1998). To create long-term competitive advantages, higher education institutions must correctly manage knowledge, which has emerged as the most precious resource for all organisations in the twenty-first century (Guzman, Jey Howard Escorcía Zuluaga-ortiz *et al.*, 2022), (Prajapati *et al.*, 2014). Globally, the information revolution that began in the late 20th century has caused human civilization to move from an industrial to a technologically advanced stage of development (Davenport & Prusak, 1998), (Education *et al.*, 2022), (Guzman, Jey Howard Escorcía Zuluaga-ortiz *et al.*, 2022), (Lynch *et al.*, 2021). The phrase "information and communication technology" (ICT) refers to a broad range of communication devices and applications, including satellite systems, computers, radios, televisions, cell phones, and network hardware and software. It also covers services like remote learning and video conferencing. Computers, digital television, email, robots, and other devices that store, retrieve, alter, transmit, or receive information electronically are all considered ICT in general. Sulisworo is cited in (Dewah & Sibanda, 2022), (Dallah & Odeh, 2022).

ICTs are used by higher education institutions for a range of instructional activities, such as research and teamwork, material access, information preservation, and content distribution. ICT is required for this purpose to efficiently support and manage knowledge as well as promote knowledge sharing, especially among lecturers (Dewah & Sibanda, 2022), (Ohemeng *et al.*, 2015), and (Yigzaw, Samuel T Jormanainen, Ilkka Tukiainen, 2019). Information with direction or information that facilitates action and decision-making is referred to as knowledge. Information is

data in context; knowledge is information that enables action; and data are just the raw facts without any context. Therefore, one definition of knowledge is having reasonable beliefs about the connections between ideas that are pertinent to a given field (Ohemeng *et al.*, 2015). Through the identification, organisation, and storage of knowledge resources as well as their dissemination to the community, knowledge management (KM) is also intended to assist higher education institutions in ensuring the sustainability of their institutions [5]. The three main components of knowledge management (KM) are people, processes, and technologies. Technology plays a major role in enhancing the development and integration of knowledge, while procedures optimise organisational design and workflow. People are the primary source of knowledge and interaction in the echo system (Yigzaw, Samuel T Jormanainen, Ilkka Tukiainen, 2019), (Ohemeng *et al.*, 2015). As a result, educational institutions need to look for creative ways to gather, distribute, and exchange knowledge, as well as learn how to use that knowledge to make wise decisions. By doing this, learning results for students will improve (Zeb, 2022).

### **Information and Communication Technology (ICT)**

In this review article, "ICT" refers to the internet and computers that are used to manage and share information for educational purposes (Mikre, 2011), (Chen *et al.*, 2015). ICTs are radically altering society. They have an impact on every facet of life. At educational institutions, the effects are becoming more noticeable (Mikre, 2011). It is a technology that facilitates information-related activities. Data collection, processing, storing, and presenting are some examples of these tasks. These operations increasingly entail cooperation and communication (Gokhe, 2020), (Sataloff *et al.*, 2004), (Bhattacharjee & Deb, 2016). Thinking about all the ways that digital technology is already being used to support individuals, companies, and organisations in using information is an excellent way to approach ICT. It refers to any device that can electronically store, retrieve, alter, transmit, or receive data in a digital format. Robots, email, digital television, personal computers, etc. are a few examples (Akinbode, 2008), (Bhattacharjee & Deb, 2016).

### **Knowledge Management (KM)**

The term "knowledge management" and its notion originated in 1990. It is as simple as organising the knowledge and information of an organisation comprehensively (Davenport & Prusak, 1998). The process of gathering, disseminating, and efficiently utilising knowledge is known as knowledge management (Prajapati *et al.*, 2014), (Omona & Lubega, 2014), and (Yigzaw, Samuel T Jormanainen, Ilkka Tukiainen, 2019). To support strategic objectives, it also refers to the process of recognising, producing, conveying, interacting with others, measuring, and enhancing knowledge (Prajapati *et al.*, 2014), (Ohemeng *et al.*, 2015).

One of the most important resources in any higher education setting is knowledge. An organization's knowledge is the foundation of its personality and uniqueness. Thus, knowledge management is essential to enhancing an organization's skills and giving it a competitive edge. The approach of providing the appropriate knowledge to the appropriate people at the appropriate time in a way that makes it easier for people to share and use information in a way that improves organisational efficiency by making use of available resources is known as knowledge management (Girard & Girard, cited in (Dallah & Odeh, 2022), (Lynch *et al.*, 2021).

### **Why Manage Knowledge?**

The amount of data transmitted to an average individual over a year has been calculated by scientists, and it is equal to the world's population reading 174 newspapers every day in Derbyshire, cited in (Prajapati *et al.*, 2014). The following three factors highlight the significance of effectively managing knowledge for an organization's success: (Prajapati *et al.*, 2014), (Kridan, A.B. Goulding, 1994).



1. Promotes innovation and cultural transformation
2. Establishes learning as a regular in organisations
3. Aids in decision-making

### **Knowledge Management Processes**

The art of knowledge management involves turning data and intellectual resources into something valuable while also satisfying tactical and strategic needs. Organizations can maximise the use of their knowledge resources with the help of knowledge management systems (KMS) (Jumba, 2020), (Omona & Lubega, 2014), (Kridan, A.B. Goulding, 1994). To improve learning and performance in organisations, it can also be defined as a set of instruments, procedures, and practices for producing, obtaining, capturing, disseminating, and utilising information, wherever it may be found. These procedures include maintaining, preserving, appreciating, and disseminating the information, as well as producing, capturing, and using it to improve organisational performance (Ohemeng *et al.*, 2015), (Lynch *et al.*, 2021), (Yigzaw, Samuel T Jormanainen, Ilkka Tukiainen, 2019).

### **ICT and Knowledge Management in Higher Institutions in Nigeria**

ICT can improve the knowledge content of services and goods and help or impede the processes of acquiring, disseminating, applying, and retaining knowledge (Dallah & Odeh, 2022), (Omona & Lubega, 2014), (Yigzaw, Samuel T Jormanainen, Ilkka Tukiainen, 2019). Understanding the important role that ICT plays in knowledge management is a given. An organisation can use knowledge management to identify, produce, represent, distribute, and facilitate the adoption of insights and experiences that make up knowledge, whether those insights and experiences are embodied in persons or are integrated into organisational procedures or practices (Evaluation & Division, 2022). Higher education institutions are entities tasked with accomplishing educational goals, including the sharing of knowledge among students, between students and teachers, and between students and books or other resources. Therefore, the difficulty faced by higher education institutions is how to generate, preserve, and distribute knowledge and information among members of the organisation (Ohemeng *et al.*, 2015), (Jumba, 2020).

By sharing important organisational insights, cutting down on unnecessary work, avoiding reinventing the wheel altogether, shortening the on boarding process for new hires, retaining intellectual capital as staff leave, and adjusting to shifting markets and environments, knowledge management (KM) initiatives can benefit both individuals and groups (Evaluation & Division, 2022), [11]. It is impossible to overstate the potential of ICT to support knowledge management procedures in education efficiently and effectively (Ohemeng *et al.*, 2015).

### **ICT and Knowledge Management for Collaborative Learning**

Higher education can benefit greatly from collaborative technologies and knowledge management (KM), but due to a lack of well-researched techniques, many organisations have not yet embraced these technologies systematically and strategically. In today's knowledge-driven society, relationships between people and organisations form the foundation of complex, dynamic exchanges that generate both concrete and intangible value through collaboration. Collaborations necessitate the ability to harness the collective knowledge of numerous people, which can only be accomplished via ongoing research, rather than just publishing, displaying, or aggregating information (Omona & Lubega, 2014), (Chen *et al.*, 2015).

### **Roles of ICT in Knowledge Management**

Today's "Knowledge Economic Era" is a result of the convergence of information and communication technologies with globalisation. In the modern world, knowledge management is

seen as a critical component of any organization's success (Prajapati *et al.*, 2014). ICT has made tremendous strides that have opened up new possibilities for it to contribute significantly to addressing the current issues surrounding information sharing, exchange, and dissemination in higher education (Chen *et al.*, 2015), (Jumba, 2020). ICT is frequently utilised in knowledge management programmes to transfer knowledge among staff members and notify clients of the most recent advancements and breakthroughs in the corporate world. Additionally, ICT makes it easier to gather organisational knowledge, gives access to knowledge that can be retrieved, and improves teamwork for the development and sharing of knowledge (Davenport & Prusak, 1998), (Prajapati *et al.*, 2014). ICTs are a technology that makes it easier for managers to communicate information and expertise. ICTs thus play a larger part in knowledge management projects. ICT has made it more necessary for businesses to create new frameworks, procedures, tools, and techniques, as well as new rules and procedures, to establish technologies and processes that will support knowledge management (Prajapati *et al.*, 2014), (Ohemeng *et al.*, 2015).

### **Conclusion**

Serious consideration should be given to the use of ICT in knowledge management if higher education institutions in Nigeria are to profit from both explicit and tacit knowledge for the accomplishment of their educational goals. If efforts are made towards effective management of institutional knowledge, the current procedures that could result in students' achievement declining upon changing subject teachers or administrators could become obsolete. An appropriate first step would be to construct information repositories. There is an urgent need to shift focus from providing computers to colleges and individuals in the educational sector to building high-quality network and Internet infrastructures for the nation's higher education institutions. The efficient use of the few computers available to the study participants is being impacted by the lack of this crucial infrastructure.

### **Recommendations**

1. It is advised that the many stakeholders in higher education make the diffusion of ICT applications in knowledge management a priority, given the low degree of access to ICT facilities among instructors, students, and administrative staff.
2. The government ought to implement information and communication technology (ICT)-driven knowledge management systems, which present notable benefits over unofficial networks in facilitating the exchange of novel insights between educators and administrators.
3. The lack of intentional knowledge management plans and strategies also necessitates institutional capacity building to create a distinct understanding of knowledge management procedures using a participative method to guarantee staff adoption.
4. The most important resource available to modern higher education institutions is most likely a steady supply of electricity and Internet connectivity.
5. To enable efficient knowledge management in educational institutions, the Nigerian government ought to set up a computer lab for instructors, learners, and administrators. Their ability and enthusiasm to use ICT in their field of work would also be enhanced by regular training and seminars.

### **References**

- [1] Akinbode, J. O. (2008). The Impacts of Information Communication Technology (ICT) on the Teaching and Learning of English as a Second Language in Nigerian Secondary Schools. *African Research Review*, 1(3), 139–152. <https://doi.org/10.4314/afrr.v1i3.41018>
- [2] Bhattacharjee, B., & Deb, K. (2016). Role of ICT in 21st Century's Teacher Education. *International Journal of Education and Information Studies*, 6(1), 1–6.

- [3] Chen, A. N., Castillo, J. G. D., & Ligon, K. (2015). Information and Communication Technologies (ICT): Components, Dimensions, and its Correlates. *Journal of International Technology and Information Management*, 24(4), 24–46. <https://doi.org/10.58729/1941-6679.1051>
- [4] Dallah, S., & Odeh, H. (2022). ICT -Based Knowledge Management in Education : A Systematic Review. *International Journal of Information Technology and Language Studies (IJITLS)*, 6(2), 1–16.
- [5] Davenport, H. T., & Prusak, L. (1998). *Working knowledge: How organizations manage what they know*. Harvard Business School Press, Boston, 35(09), 1–15. <https://doi.org/10.5860/choice.35-5167>
- [6] Dewah, P., & Sibanda, F. (2022). ICTs for enhancing knowledge management amongst academics at the National University of Science and Technology, Zimbabwe. *South African Journal of Library and Information Science*, 88(1), 1–10. <https://doi.org/10.7553/88-1-2120>
- [7] Education, T., Tregubova, T., Ng, J., & Kopnov, V. A. (2022). New roles and competencies of teachers in the ICT-mediated learning environment of Russian universities. *The Education and Science Journal*, 24(1), 191–221. <https://doi.org/10.17853/1994-5639-2022-1-191-221>
- [8] Evaluation, S. E., & Division, T. T. (2022). Role of ICT in Knowledge Management. *Socio Economic Evaluation & Technology Transfer Division Central Marine Fisheries Research Institute, Kochi, Kerala*, 507–527.
- [9] Gokhe, M. (2020). Concept of ICT. In *Information and Communication Technology* (pp. 1–68). [https://www.hzu.edu.in/csit/IV.1\\_information\\_and\\_communication\\_technology.pdf](https://www.hzu.edu.in/csit/IV.1_information_and_communication_technology.pdf)
- [10] Guzman, Jey Howard Escorcia Zuluaga-ortiz, R. A., Barrios-Miranda, D. A., Delahoz-dominguez, E. J., & Lahoz-dominguez, E. J. (2022). Science Direct Information and Communication Technologies ( ICT ) in the processes of distribution and use of knowledge in Higher Education processes of distribution and use of knowledge. *The 2nd International Workshop of Innovation and Technologies (IWIT 2021) Procedia Computer Science* 198 (2022), 1(4), 644–649. <https://doi.org/10.1016/j.procs.2021.12.300>
- [11] Jumba, H. (2020). Use of ICTs in Knowledge Management for Enhanced Institutional Sustainability. 5(1).
- [12] Kridan, A.B. Goulding, J. S. (1994). *The Role of Information and Communication Technology in Knowledge Management Activities within the Banking Industry*.
- [13] Lynch, M., Sage, T., Hitchcock, L. I., & Sage, M. (2021). A heutagogical approach for the assessment of Internet Communication Technology (ICT) assignments in higher education. *International Journal of Educational Technology in Higher Education (Springer)*, 18(1). <https://doi.org/10.1186/s41239-021-00290-x>
- [14] Mikre, F. (2011). The Roles of Information Communication Technologies in Education: Review Article with Emphasis on the Computer and Internet. *Ethiopian Journal of Education and Sciences*, 6(2), 1–16.
- [15] Ohemeng, P., Twum, E., & Nii, I. (2015). The Use of Information and Communication Technology (ICT) for Knowledge Management in the Second Cycle Educational Institutions in Ghana. *International Journal of Computer Applications*, 128(7), 7–13. <https://doi.org/10.5120/ijca2015906600>
- [16] Omona, W., & Lubega, J. T. (2014). Using ICT to enhance Knowledge Management in higher education: A conceptual framework and research agenda. *International Journal of Education and Development Using Information and Communication Technology (IJEDICT)*, 6(4), 83–101.
- [17] Prajapati, A., Upadhyay, S., & Boria, R. (2014). Knowledge Management and Role of ICT for Development. *International Journal of Scientific Research and Management (IJSRM)*, 2(10), 1583–1586.
- [18] Sataloff, R. T., Johns, M. M., & Kost, K. M. (2004). *Introduction to Computer Security*.

- [19] Yigzaw, Samuel T Jormanainen, Ilkka Tukiainen, M. (2019). Trends in the Role of ICT in Higher Education Knowledge Management Systems: A Systematic Literature Review. *Transactions on Electrical and Electronic Materials (TEEM)*, 19(10), 2–8.
- [20] Zeb, S. (2022). The role of knowledge economy in Asian business. *Future Business Journal*, 8(1), 1–13. <https://doi.org/10.1186/s43093-021-00112-6>

# The Strategy of Academic Libraries for Promoting Open Access Resources in Electronic Media: A Study of Management Institutes in the Mumbai Metropolitan Area

Sangeeta Kamble<sup>1</sup> and Dr. Mayank Trivedi<sup>2</sup>

<sup>1</sup>Assistant Librarian & Research Scholar, SVKM's NMIMS, Bengaluru, Karnataka, India

<sup>2</sup>University Librarian, <sup>1&2</sup>The Maharaja Sayajirao University of Baroda, Gujarat, India

E-mail: Sangeeta.kamble@nmims.edu, librarian-hml@msubaroda.ac.in

## Abstract

*The present study highlights the approaches that encourage open access and the challenges librarians encounter when working towards this goal. It was said that it is essential to devise a marketing or promotional strategy to extend open access in libraries. Electronic media changed the academic libraries' role, and now they recognize that research tools are growing in tandem with technology. The present study highlights the approaches that encourage open access and the challenges librarians encounter when working towards this goal. It was said that it is essential to devise a marketing or promotional strategy to extend open access in libraries. This study seeks to identify the techniques used to promote these resources and the obstacles that prevent their promotion. The study found that open-access resources are significant for academic purposes; librarians need to take the lead and introduce users to them.*

**Keywords:** Academic libraries, open access, marketing strategy, scholarly publication, information literacy, research support.

## Introduction

In this digital age, the library serves as a medium for the dissemination of scholarly work; innovative inclusion platforms and operating models facilitate access to literary work. It is difficult for academic libraries to meet the demands of their users within their limited budgets as resource prices rise on a daily basis. This challenge encourages libraries to use open source resources. The evolution of open access begins in 1990 as a replacement for traditional publishing models. Access to available resources is being increased by the availability of internet services in this decade. Technological advancements have had a tremendous impact on libraries, and academic libraries are now acting as intermediaries in research work. Open access to research is very important; it has a wide range of consequences for the academic community. Open access is critical for expanding access to knowledge, promoting cooperation, and advancing research in an ethical, transparent, and efficient manner. It adheres to openness and inclusivity ideals, making scholarly communication equal and influential. It upholds the values of inclusivity and openness, increasing the equality and impact of scholarly communication. With the growth of open access resources and discovery services, academic libraries face competition, and as a result, academic libraries provide scholarly documentation through open access and institutional repositories. (Burns 2014). By incorporating open-access concepts into traditional librarian roles, academic libraries can improve their services. (Cryer 2013). Academic librarians can help researchers by providing access to resources and tools as well as scholarly publishing. (Zhao 2014). Since there is a vast amount of educational content available in open access today, it is the responsibility of librarians to make users aware of these resources or introduce them to other kinds of open-access content. Creating a marketing or promotional plan for expanding open access in libraries is crucial. The article discusses the strategies for supporting open access and the obstacles faced by librarians in this endeavour.

## Literature Review

Anunobi (2017) examines the importance of promoting open-access materials and concludes that the library must take the initiative in this area as an essential partner and user of OAR. Arendt (2009) this article investigates Utah residents' perceptions of Open Courseware (OCW) incentives and disincentives and how they fit into Rogers' theoretical framework of perceived innovation qualities (1983). The authors recommend that schools aim to convert select OCW users into paid degree-granting courses and launch a marketing campaign to boost OCW awareness. Furthermore, OCW websites should make their content available to recommendation engines like ccLearn Discovered, OCW Finder, and OER Recommender and link to one or more websites. Christoforou and Georgiadou (2022). This study underlines the benefits of OER and emphasizes OER awareness. The paper indicates the need to know OER. It was established that educators, university administrators, and librarians could increase user awareness of OER by informing them of its advantages.

Dill (2008) this article presents the findings of a national study of academic librarians' opinions about open access principles and related activities conducted during the summer of 2006. While attitudes were generally positive, there were disparities in support levels based on respondents' job descriptions and financing for open-access initiatives. Librarians are more comfortable with occupations that translate conventional commitments, like education, to an open-access situation. Fallon (2020) the study focuses on the financial analysis and best practices for marketing to the stakeholders of the College of Staten Island (CSI) library, which could be used for its open educational resources (OER) and patron-driven acquisition (PDA) programs. The research examines how economic analysis outcomes might be utilized to campaign for funding, help people make good decisions about resources, and promote different projects in an academic library.

Fernandez (2011) in the context of an evolving literary publishing scene, the broader consequences of sponsoring open Access are examined. This report will particularly interest Canadian academic libraries exploring funding alternatives for open-access publishing. Frisen, 2009 this study demonstrates the results of an unofficial survey of active and inactive collections of online educational resources, with a focus on data about how long a group has been around and what its project characteristics are. It is said that pointing out these benefits gives institutions a chance to link OER projects to their most important goals. This feature of OERs may bring about the significant changes in practice and culture that supporters of both learning objects and OERs have been hoping for a long time. Hatzipanago & Gregson's (2015) this study examines the role of Open Access (in licensing, publishing, and sharing research data) and Open. This case study examines existing Open Access practices; the research studies the difficulties of employing OER and their consequences. This study aims to create awareness and identify the essential procedures to improve academic institutions' utilization of open-access resources.

Jain (2012) this report evaluates the attempts of academic libraries to promote open Access. It will also examine the hurdles and challenges associated with open Access, focusing on developing nations. The first step would be to comprehend the concept of Open Access. Kakai & *et al.*, (2018) Given that repositories were offered as one of the pathways to Open Access (OA), the objective of this study was to determine the progress universities in East Africa had made in establishing institutional repositories (IRs), the obstacles in delivering OA, and the strategies for moving forward. Mwinyimbegu (2018) this study investigated the role of librarians in open educational resources. The research sought to ascertain librarians' state of OER awareness and the role of libraries and librarians in OER. The survey also identified the challenges librarians encounter in improving Access to and adoption of OER.

Nkuybwatsi (2018) The study could help fund groups, teachers, and institutions that want to support or get involved in the creation, adaptation, and use of open educational resources (OER) to help open up higher education.

Sutton and Fruin (2016). This essay addressed the first issue by examining the findings of a survey of fifty-one universities in North America that had adopted open access policies. This study establishes the base for future analysis of the impact of these policies by recording the policy creation and promotion experiences of many institutions. While the academic library community appears to regard open access rules as a "positive thing," there is an urgent need to measure institutional policies' substantial impact to determine their genuine value.

### Statement of the Problem

Open access (OA) is a more contemporary method of scientific publication; many OA journals adhere to strict publishing standards, follow established peer-review practices, and make scholarly work available to everyone. A lot of information is made available to readers thanks to open-access resources, making it crucial for academic librarians to educate their users about these resources. The study aimed to identify the marketing tactics used by academic libraries to improve user access to and discovery of open-access resources. It aimed to identify the open access resource model supported by Mumbai's management institution libraries, ascertain the librarians' opinion of how faculty in Mumbai's management libraries use open access resources, determine the promotion tactics used by the librarians to improve access and discovery of open access resources, and ascertain the barriers to such promotion.

### Objectives of the Study

1. Determine the open access promotion strategy in libraries
2. Recognizing the Obstacles to Promoting OA
3. To learn about a librarian's appearance in open access.

### Methods

The survey method is used to collect data for the study, which employs the qualitative research method. The study employed an exploratory data analysis method. The study's focus is on management institutes in the Mumbai metropolitan area. Choose the top 50 management libraries for the research. The data was gathered from library professionals only. The target population is 50 people, and 39 people responded.

### Data Analysis and Interpretation

Total 39(78%) responses received, collected data was analysed by gender wise, and there was 17 (43.58%) female and 22 (56.41%) male respondents respond the survey.

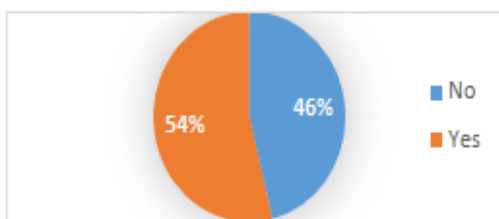

Fig.1 Gender

Chart 1 indicates that 21 (54%) librarians build an open access repository in their library, while 18 (46%) do not, indicating that some librarians still do not recognize the significance of OA or do

not take appropriate steps in this direction. It shows that there is need to take initiate to create open access repository.

To determine whether librarians encourage their users to use open access, 20 (51.28%) say no, while 19 (48.71%) say yes. It indicates in chart 2.

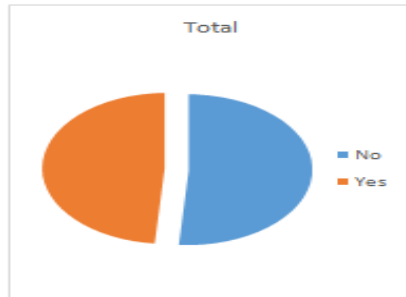

Fig.2 Encourage to Use OA

The percentage of encouraging users is low; hence, the study recommends that librarians take the initiative to encourage users to use OA resources.

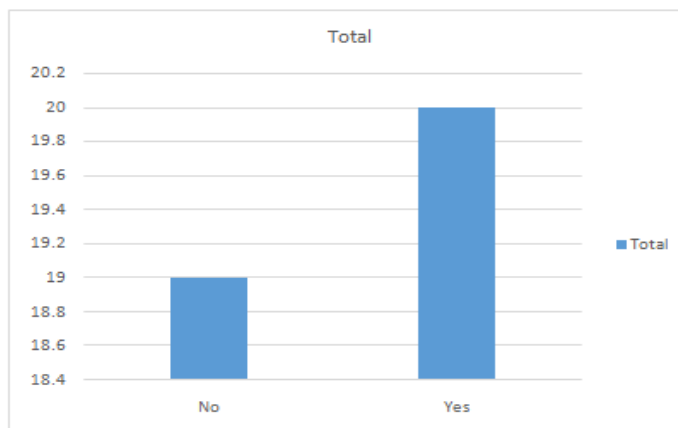

Fig.3 Library Platform for Open Access

Chart 3 indicate that, 20 (21.28) librarians build separate OA platforms at the library, while 19 do not.

Chart 4 depicts the practices adopted for promoting open access; these are multiple-choice question from which respondents may choose more than one answer. 11 responses (28.20%) preferred Faculty Education on the Benefits of OAR. Seven (17.94%) respondents chose Integrate OAR into Current Awareness services and Suggested open access when obtaining information resources. 14 (35.89%) choose Embedded librarians to advocate for using OARs. 15 respondents (38.46%) favour introducing OAR at library orientations. 21 respondents (53.84%) indicated that they celebrate Open Access Week, while 11 (28.20%) indicated hosting workshops on copyright concerns and digital scholarship. 15 (38.46%) of respondents select Indexing & Abstracting services. 21 (53.84%) opt for networking.



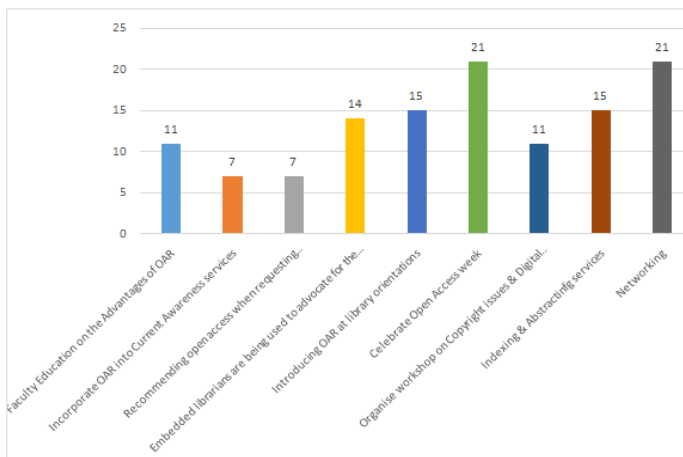

Fig.4 Practices Adopted for the Promotion of Open Access

Chart 4 depicts the difficulties in promoting open access. 19 (48.7%) agreed that OA's concepts and strategies need to be clarified. 20 (51.28%) claim Uncertainty About Varieties of OA, 19 (48.7%) say Overabundance of Resources, and 23 (58.97%) mention Lack of Knowledge and Skills. 19 (48.71%) individuals agreed that there was Confusion between the procedure and the outcome, 13 (33.33%) acknowledged that the resources were insufficient for in-depth analysis, and 21 (53.84%) cited overall organizational obstacles.

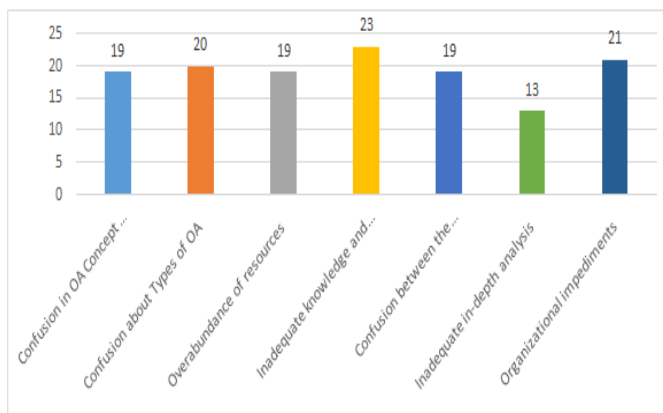

Fig.5 Challenges in Promotion of Open access

### Findings and Suggestions

The research found that open-access resources are still in the early stages in management libraries in the Mumbai metropolitan area. It suggests that librarians start open-access initiatives such as creating open-access repositories and developing a different open-access library platform. Libraries have made significant contributions to the open-access movement. Libraries introduced open-access journals to their users by providing indexing services while also serving the international community by delivering preferred proper and efficient scholarly communication—librarians play an essential role in the establishment and management of repositories. Librarians confront various obstacles whenever it comes to open-access resources. Faculty and research

scholars are unfamiliar with open-access resources and must be guided in their use. Faculty participation and the issue of quality are also significant challenges for librarians; librarians must work with faculty to evaluate content for research quality. Academic libraries face the challenge of information overload, making it difficult to provide accurate information to appropriate users. Academic libraries are now involved in challenging activities that help people analyse, identify, and meet their information needs. Open-access resources help them meet their users' needs.

### Conclusion

Library professionals mostly facilitate promotion of open access resources. Therefore, they are able to satisfy their patrons and supply the necessary information within their budget, despite the economic difficulties facing libraries. The expansion of open access resources is crucial for the advancement of research. The library should collaborate in order for their institute's research to gain from open access materials. By implementing an information marketing strategy, libraries can promote open access resources in their libraries, thereby redefining the collection and services of the library. Due to the internet's easy access, open-access resources are well liked by readers compared to the past few years. Skilled librarians are the primary promoters of open resources.

### References

- [1] Alam, I. (2014). Changing role of academic librarians in open access environment. *International Research: Journal of Library and Information Science*, 4(4)
- [2] Anunobi, C. V., & Ape, R. (2018). Promotional strategies for open access resources discovery and access. *Webology*, 15(1), 30-45.
- [3] Bosc, H., & Harnad, S. (2005). In a paperless world a new role for academic libraries: providing open access. *Learned Publishing*, 18
- [4] Burns, C. Sean, "Academic Libraries and Open Access Strategies" (2014). Information Science Faculty Publications. 8.
- [5] Charles W. Bailey Jr. (2007) Open Access and Libraries, *Collection Management*, 32:3-4, 351-383
- [6] Emma Cryer (Contributor) (2011) Incorporating Open Access into Libraries, *Serials Review*, 37:2, 103-107.
- [7] Horstmann, W. (2017). From collecting to connecting – the role of libraries in Open Access. In Söllner K. & Mittermaier B. (Eds.), *Praxishandbuch Open Access* (pp. 62-74). Berlin; Boston: De Gruyter.
- [8] Jain, Priti, "Promoting Open Access to Research in Academic Libraries" (2012). *Library Philosophy and Practice* (e-journal). 737.
- [9] Joshi, Anupama N.; Vatnal, R M.; and A, Manjunath G., "Open Access Initiatives: A Boon to Academic Libraries" (2012). *Library Philosophy and Practice* (e-journal). 792
- [10] Karen Okamoto (2013) Making Higher Education More Affordable, One Course Reading at a Time: Academic Libraries as Key Advocates for Open Access Textbooks and Educational Resources, *Public Services Quarterly*, 9:4, 267-283
- [11] Linlin Zhao (2014) Riding the Wave of Open Access: Providing Library Research Support for Scholarly Publishing Literacy, *Australian Academic & Research Libraries*, 45:1, 3-18,
- [12] Sanjeeva Meghana Manohar, Podwal Sushma C (2017) Open Access Initiatives: Reframing the role of Librarians, *Library Herald*, vol 55 no 4,
- [13] Siddiqui, Intekhab Alam, Changing Role of Academic Librarians in Open Access Environment (August 26, 2014). *International Research: Journal of Library & Information Science*, Vol. 4 No. 4.
- [14] Wessels, B., Finn, R., Linde, P., Mazzetti, P., Nativi, S., Riley, S., Wyatt, S. (2014). Issues in the development of open access to research data. *Prometheus*, 32(1), 49-66.

# Open Source Library Management Software: A Comparative Study of KOHA and Evergreen

Rinku<sup>1</sup> and Dr. DharamVir Singh<sup>2</sup>

<sup>1</sup>Research Scholar (PhD), <sup>2</sup>Associate professor

<sup>1&2</sup>Department of Library & Information Science, Mangalayatan University, Uttar Pradesh, India

E-mail: rrrinku6@gmail.com, hodlibrarysrcd@gmail.com

## Abstract

*This study presents a comparative analysis of two prominent open-source library management software solutions, Koha and Evergreen. The focus is on evaluating their features, functionalities, and performance to assist libraries in making informed decisions regarding the implementation of a suitable system. The study employs a comprehensive approach, considering aspects such as user interface, customization options, scalability, and community support. The findings aim to provide librarians, administrators, and decision-makers with valuable insights into the strengths and weaknesses of Koha and Evergreen, aiding them in selecting the most suitable solution for their specific needs. By comparing these open-source platforms, this study contributes to the existing knowledge base on library management systems and supports the continuous improvement of open-source software in the library domain.*

**Keywords:** Open Source Software, Library Management Software, KOHA, Evergreen

## Introduction

In the rapidly evolving landscape of library management, the adoption of open-source solutions has emerged as a transformative paradigm, offering libraries cost-effective, customizable, and community-driven alternatives to proprietary systems. At the forefront of this movement stand Koha and Evergreen, two prominent open-source library management software platforms. This study endeavors to present a nuanced exploration and comparison of these systems, aiming to furnish librarians, administrators, and decision-makers with insights crucial for informed decision-making. The modern library ecosystem is characterized by an increasing demand for digital services, dynamic cataloging, and seamless user experiences. Koha and Evergreen have garnered widespread attention for their capacity to address these challenges, each bringing its own set of features and functionalities to the table. However, the choice between these systems necessitates a comprehensive understanding of their respective strengths, weaknesses, and suitability for diverse library environments.

The motivation behind this study lies in the recognition of the pivotal role that library management systems play in shaping the efficiency and effectiveness of library operations. By conducting a comparative analysis of Koha and Evergreen, this research aims to shed light on critical aspects such as user interface design, customization options, scalability, and community support. These factors, among others, form the basis for evaluating the overall performance and compatibility of these open-source solutions with the diverse needs of libraries. As open-source solutions gain traction in the library domain, the need for a thorough examination of available options becomes paramount. This study is positioned as a timely and relevant contribution to the discourse surrounding open-source library management systems. It is anticipated that the findings will not only aid libraries in the selection process but also contribute valuable insights to the broader community involved in the development and enhancement of open-source software for libraries. Through this exploration, the study endeavors to facilitate a more informed and strategic approach to adopting open-source library management systems, ensuring that libraries are well-equipped to navigate the evolving landscape of information management.

### **Objectives of this Study**

The primary objectives of this study are as follows.

1. To assess the features and functionalities of KOHA and Evergreen.
2. To analyze the user interface and customization options of both systems.
3. To evaluate the scalability and performance of KOHA and Evergreen.
4. To examine the level of community support and development activities for each platform.

### **Overview of the Study**

This comparative study delves into the realm of open-source library management software, focusing on the widely-used platforms Koha and Evergreen. The overarching objective is to provide libraries and information professionals with a comprehensive understanding of these systems, aiding in informed decision-making regarding the adoption of open-source solutions. The study embraces a holistic approach, addressing key dimensions crucial to the effective functioning of library management software. System architecture, database structure, user interface design, customization options, scalability, and community engagement are among the pivotal aspects explored. Through a structured framework, the research seeks to illuminate the unique features, strengths, and weaknesses of both Koha and Evergreen. The methodology involves a thorough literature review, incorporating insights from academic studies, articles, and documentation related to open-source library management systems. Additionally, the study employs hands-on exploration and testing of Koha and Evergreen to provide practical insights into their functionalities. Collaboration with library professionals and users contributes real-world perspectives, enhancing the study's applicability.

As libraries increasingly turn to open-source solutions to meet their diverse needs, understanding the nuances of Koha and Evergreen becomes imperative. This study aims to bridge existing knowledge gaps and empower libraries in making informed decisions regarding the implementation of a robust and tailored library management system. Ultimately, the research strives to contribute to the ongoing improvement and advancement of open-source software in the dynamic landscape of library and information management.

### **Literature Review**

Marshall Breeding (2021) highlights evolving trends in library technology, providing context for the relevance of open-source solutions in the contemporary library landscape. Pymm and Jolly's book (2013) and the chapter by Raju and Usha (2018) offer detailed insights into Koha, focusing on its features and practical implementation. Byrum's framework (2016) for evaluating open-source library systems guides the criteria used in this comparative study. The articles by the Library and Information Technology Association (2014) Spohn and Daugherty (2017) along with Gallagher's exploration of Evergreen's architecture and capabilities (2012), contribute to the understanding of open-source solutions. Coyle and D'Ignazio (2009) and Tennant (2009) lay the groundwork for the landscape of library management systems, emphasizing the significance of open-source solutions. Together, this literature sets the stage for a comprehensive and informed comparative study of Koha and Evergreen in the context of open-source library management software.

### **Open Source Library Management Software with Reference to Koha and Evergreen**

#### **KOHA**

Koha is an open-source integrated library system (ILS) renowned for its flexibility and extensive feature set. Developed in 1999 by the Horowhenua Library Trust in New Zealand, Koha has gained global popularity for its user-friendly interface and adaptability to various library sizes and types. One of its distinguishing features is its web-based architecture, allowing users to access the

system from any device with an internet connection. Koha supports a range of library functions, including cataloging, circulation, acquisitions, and patron management. Its robust community-driven development model ensures regular updates, and its active user community contributes to ongoing enhancements. Koha's open-source nature empowers libraries to customize the system to meet their unique requirements, making it a widely embraced solution for modern library management.

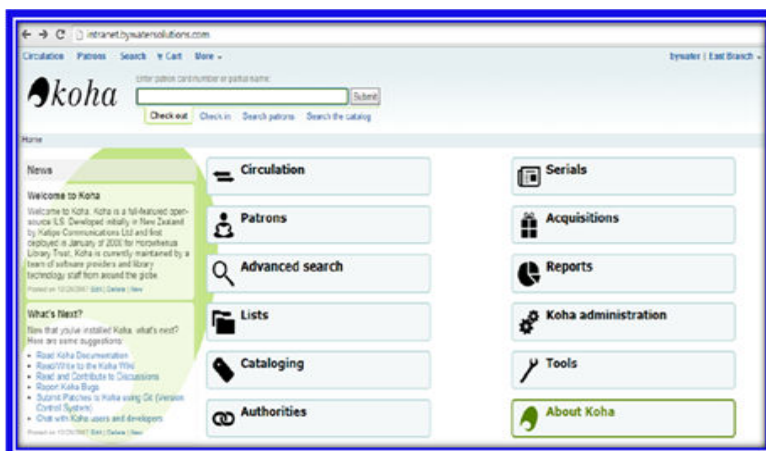

Fig.1 Open Source Library Management Software KOHA

## Features in KOHA

Koha is a widely used open-source integrated library system (ILS) that provides a range of features for managing library collections and services. As of my last knowledge update in January 2022, here is a list of some key features in Koha.

1. *Cataloging*
  - a. MARC21 and UNIMARC support
  - b. Import and export of bibliographic records
  - c. Authority control
2. *Acquisitions*
  - a. Purchase suggestions
  - b. Vendor management
  - c. Budget management
  - d. Order creation and management
3. *Circulation*
  - a. Check in/check out
  - b. Holds and reservations
  - c. Renewals
  - d. Fines and fees management
4. *Patron Management*
  - a. Member registration and profiles
  - b. Circulation history
  - c. Holds and requests management for patrons

5. *Serials Management*

- a. Subscription management
- b. Serials control

6. *OPAC (Online Public Access Catalog)*

- a. Web-based catalog for users
- b. Search and browse functionality
- c. Account management for patrons

7. *Reporting and Statistics*

- a. Customizable reports
- b. Statistical analysis tools

8. *Inter-Library Loan (ILL)*

- a. Request and manage inter-library loans

9. *Multilingual Support*

- a. Interface available in multiple languages

10. *System Administration*

- a. User roles and permissions
- b. System configuration settings

11. *Integration*

- a. Integration with RFID technology
- b. Integration with various payment gateways
- c. Integration with external systems and databases

12. *Accessibility*

- a. ADA (Americans with Disabilities Act) compliance for accessibility

13. *Customization*

- a. Theming and branding options
- b. Customizable templates

14. *Security*

- a. User authentication and authorization
- b. Data encryption

## **Evergreen**

Evergreen, initiated by the Georgia Public Library Service in 2006, is another powerful open-source library management system designed for consortium use. Built on a robust platform, Evergreen excels in handling large collections and interlibrary cooperation. Its architecture supports shared catalogs and resource sharing across multiple libraries, making it an ideal choice for consortia and library networks. Evergreen offers a range of features such as cataloging, circulation, and acquisitions, and its design emphasizes scalability and reliability. The system's strength lies in its ability to efficiently manage complex, multi-branch library systems. Evergreen's collaborative development approach ensures continuous improvement, and its commitment to open standards fosters interoperability within the library community. As an open-source solution, Evergreen provides libraries with the freedom to tailor the system to their specific needs,

enhancing its appeal for organizations seeking adaptable and scalable library management solutions.

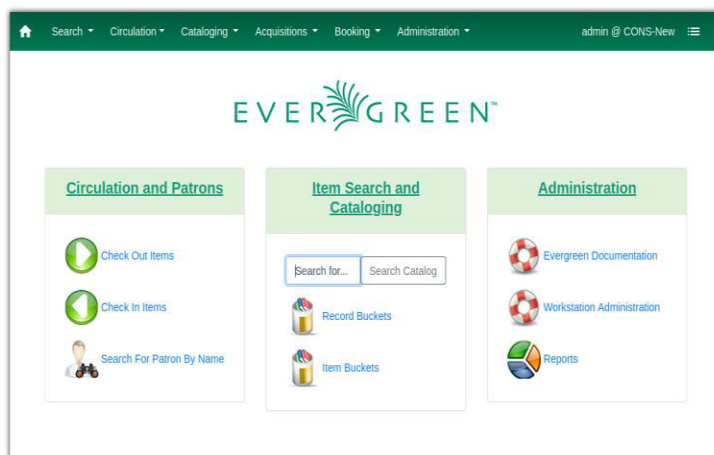

Fig.2 Open Source Library Management Software Evergreen

### Features in Evergreen

Evergreen is another open-source integrated library system (ILS) that is known for its scalability and flexibility. As of my last knowledge update in January 2022, here is a list of some key features in Evergreen.

1. *Cataloging*
  - a. MARC21 support
  - b. Import and export of bibliographic records
  - c. Authority control
2. *Acquisitions*
  - a. Purchase suggestions
  - b. Vendor management
  - c. Budget management
  - d. Order creation and management
3. *Circulation*
  - a. Check in/check out
  - b. Holds and reservations
  - c. Renewals
  - d. Fines and fees management
4. *Patron Management*
  - a. Member registration and profiles
  - b. Circulation history
  - c. Holds and requests management for patrons
5. *Serials Management*
  - a. Subscription management
  - b. Serials control

6. *OPAC (Online Public Access Catalog)*
  - a. Web-based catalog for users
  - b. Search and browse functionality
  - c. Account management for patrons
7. *Reporting and Statistics*
  - a. Customizable reports
  - b. Statistical analysis tools
8. *Inter-Library Loan (ILL)*
  - a. Request and manage inter-library loans
9. *Multilingual Support*
  - a. Interface available in multiple languages
10. *System Administration*
  - a. User roles and permissions
  - b. System configuration settings
11. *Integration*
  - a. Integration with RFID technology
  - b. Integration with various payment gateways
  - c. Integration with external systems and databases
12. *Accessibility*
  - a. ADA (Americans with Disabilities Act) compliance for accessibility
13. *Customization*
  - a. Theming and branding options
  - b. Customizable templates
14. *Security*
  - a. User authentication and authorization
  - b. Data encryption

## **Discussion**

Koha and Evergreen are both robust open-source library management systems designed to streamline and automate various aspects of library operations. Koha, with its modular architecture, offers a comprehensive suite of features, including cataloging, acquisitions, circulation, and patron management. It emphasizes flexibility and customization, providing libraries with the ability to tailor the system to their specific needs. On the other hand, Evergreen is known for its scalability, making it suitable for large library consortia. It shares many core features with Koha, including cataloging, circulation, and acquisitions, and is renowned for its efficient handling of inter-library loans.

Libraries often choose between Koha and Evergreen based on factors such as their specific requirements, preferences for customization, and the size and complexity of their library networks. Both systems contribute significantly to the open-source library management community, offering viable alternatives to proprietary solutions.



## Conclusion

In the dynamic landscape of library management, the comparative study of Koha and Evergreen has provided valuable insights into two prominent open-source solutions, each contributing distinct strengths to the realm of library automation. Koha, with its inception in 1999, has established itself as a versatile and user-friendly system, appealing to a diverse range of libraries. Its web-based architecture, active community support, and customizable features make it a compelling choice for institutions seeking flexibility and adaptability in their library operations. On the other hand, Evergreen, emerging in 2006, has demonstrated its prowess in handling large, consortia-based library networks. Its focus on scalability and resource sharing sets it apart, making it particularly suitable for organizations with complex multi-branch structures. Evergreen's commitment to open standards and collaborative development underscores its dedication to interoperability and continuous improvement. The comparative analysis encompassed various dimensions, including system architecture, database structure, user interface design, customization options, scalability, and community support. Each system exhibited unique strengths and considerations, catering to different library contexts and requirements. The choice between Koha and Evergreen ultimately depends on the specific needs, size, and nature of the library or consortium. As libraries evolve to meet the challenges of the digital age, the open-source nature of both Koha and Evergreen positions them as sustainable and cost-effective solutions. The vibrant communities surrounding these systems ensure ongoing development and support, fostering innovation in library technology. The comparative study contributes to the broader understanding of open-source library management software, providing librarians, administrators, and decision-makers with nuanced insights. Libraries must carefully weigh the features, scalability, and community support of Koha and Evergreen to align with their unique goals. The continuous development and commitment to open standards from both systems reflect the resilience and adaptability required to meet the evolving needs of modern libraries.

## References

- [1] Breeding, M. (2010). Library Systems Report 2010. *Library Technology Reports*, 46(7), 5-13.
- [2] Byrum, J. M. (2016). Evaluating Open Source Library Systems. *Information Technology and Libraries*, 35(3), 5-18.
- [3] Coyle, K., & D'Ignazio, J. (2009). Open Source Integrated Library Systems. *Library Technology Reports*, 45(8), 5-8.
- [4] Gallagher, M. A. (2012). Evergreen: The Open-ILS Initiative. *Information Standards Quarterly*, 24(4), 14-20.
- [5] Library and Information Technology Association. (2014). Top Technology Trends in Libraries: A Review. *Information Technology and Libraries*, 33(2), 2-11.
- [6] Marshall Breeding. (2021). Library Systems Report 2021. *American Libraries*, 52(4), 23-27.
- [7] Pymm, B., & Jolly, B. (2013). *Koha in Libraries*. Chandos Publishing.
- [8] Raju, J., & Usha, R. (2018). Koha: Open Source Software in Libraries. In S. A. Vijayakumar (Ed.), *Open Source Integrated Library Systems: A Handbook of Library Automation and Digitization* (pp. 1-13).
- [9] Spohn, D., & Daugherty, S. (2017). Choosing a Library Automation System: Koha and Evergreen. *Computers in Libraries*, 37(6), 28-31.
- [10] Tennant, R. (2009). Open Source Software for Libraries. *Library Technology Reports*, 45(4), 5-10.

# A Study on the Design and Implementation of SLIMS at Kongu SRV International School Library

S. Vijay<sup>1</sup> and S. Gunaseelan<sup>2</sup>

<sup>1</sup>Librarian, Kongu SRV International School, Salem, Tamil Nadu, India

<sup>2</sup>Research Scholar, Department of Library and Information Science

Bharathidasan University, Tiruchirappalli, Tamil Nadu, India

E-mail: lisvijay19@gmail.com, gunaseelan2703@gmail.com

## Abstract

*This research explores the implementation of the Senayan Library Management System (SLIMS) in Kongu SRV International School Library. SLIMS, open-source library management software, offers features like Online Public Access Catalog, digital content support, and comprehensive bibliographic database management. The paper details SLIMS' installation process, system requirements, and functionalities, illustrated with screenshots. The outcomes highlight enhanced control over library operations, improved accessibility through OPAC, and the consolidation of collections in a single database. The study emphasizes SLIMS' transformative impact on library efficiency and resource management.*

**Keywords:** Library Automation, Senayan Library Management System (SLIMS), OpenSource Software, School Libraries, Digital Content Management, and Kongu SRV International School.

## Introduction

Automation is becoming inevitable in every industry, including medium-scale and school libraries. Library automation is the process of employing application software in the library for data entry, circulation of books, maintenance of records in MARC format, serial control, stock verification, and other functions. School libraries can automate their library operations by transforming conventional tasks with the help of open-source software. Senayan Library Management System (SLIMS) is open source integrated library management software originally developed in Indonesia with a variety of developers from the different parts of the world. The software was awarded in the category of Open Source by Indonesian ICT Award -2009. Since SLiMS is developed based on Unicode and also it was very good built-in feature. The SLiMS bullion 9 is the last upgraded version. Also it is available in portable format, which can have records of 1000 books.

## About KSRV School Library

The Kongu SRV International School was started at Salem on 3rd June 2020. Currently school has 47 teachers and 556 students. The special interest shown by the school management and librarian of KSRVIS, the library has achieved very good response among students. Kongu SRV International school library has been established in the year 2020 and currently it has over 2700 books. The library book has been classified recently with DDC. Accordingly the study has taken up to automate the library operations.

## Salient Features of SLIMS

The various features of SLIMS (Senayan Library Management System), a comprehensive library management system, will make it easier and faster for librarians and libraries to perform their tasks. Here are a few features that SLIMS offers.

1. Online Public Access Catalog (OPAC) with thumbnail document image support (for images of book covers), Simple Search and Advanced Search mode
2. Digital contents/files (PDF, DOC, RTF, XLS, PPT, Video, Audio, etc.): attachment in each bibliographic record is supported

3. Documents record detail in MODS (Metadata Object Description Schema) XML format
4. Documents record detail in JSON-LD format with schema.org
5. RSS (Really Simple Syndication) XML format for OPAC
6. OAI-PMH (Open Archives Initiative Protocol for Metadata Harvesting) in Dublin Core format for metadata harvesting purposes
7. Bibliographic/catalog database management with book cover image support
8. Union Catalog creation with Union Catalog Server
9. Serial publication control
10. Federated search engine creation with Nanyang
11. Document items (book copies) management with barcode support
12. Master Files management to manages document referential data such as GMD, Collection Types, Publishers, Authors, Locations, Authors and Suppliers
13. Circulation support with following sub-features :
  - a. Loan and Return transactions
  - b. Collections reservations
  - c. Quick returns
  - d. Configurable and flexible Loan Rules
  - e. Membership management
  - f. Stocktaking module to help Stocktaking process in the library
  - g. Reporting and Statistics
14. System modules with the following sub-features :
  - a. Global system configuration
  - b. Modules management
  - c. Application Users and Groups management
  - d. Holiday settings
  - e. Barcodes generator utility
  - f. Database backup utility
15. Responsive user interface
16. 3rd party bibliographic records indexing support with Sphinx Search and Mongo DB

### **Requirements of SLIMS Software**

The following are the minimum requirements of SLIMS.

1. Computer with 8 to 16 GB RAM
2. Apache web server version 2.4;
3. MySQL version 5.7 and or Maria DB version 10.3
4. PHP Version 8.1
5. PHP GD enabled
6. PHP get text enabled
7. PHP mb string
8. Php My Admin and Or Adminer (optional)

### **Procedures to Install SLIMS**

The requirements checked and internet connection also checked. The latest version of XAMPP and SLIMS packages were checked for download.

### **Download and Install XAMPP**

To install SLIMS, We need Apache server and SQL database for that we have to download & install XAMPP latest version, which is an open source package of Apache, MySQL, PHP and Perl.

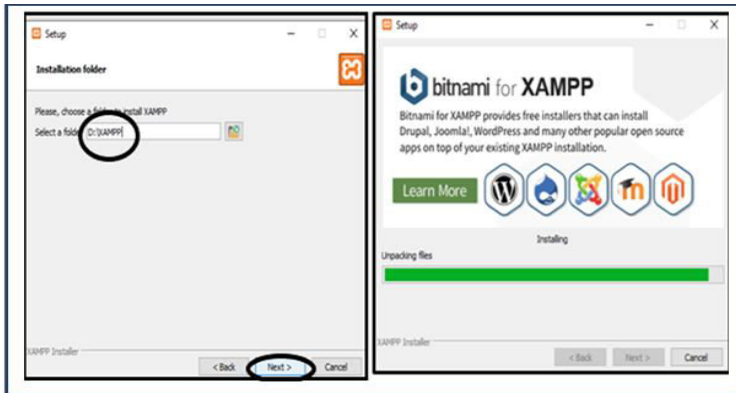

Fig.1 XAMPP Installation process

Also we should install XAMPP except in Local disk C, to avoid System slowdown. After installed we can start Apache and MySQL from XAMPP control panel.

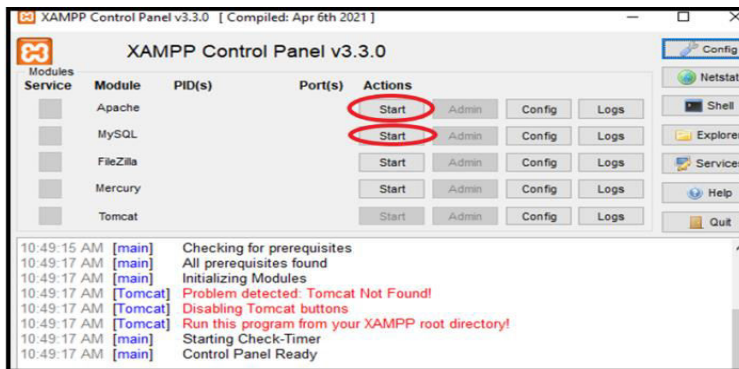

Fig.2 XAMPP Control panel

### Download SLIMS and Extract Code

The Source code of SLIMS 9 downloaded as zip file from <http://slims.web.id/web/>. Then Extracted the SLIMS Zip file under the htdocs folder in XAMPP folder and renamed into slims9.

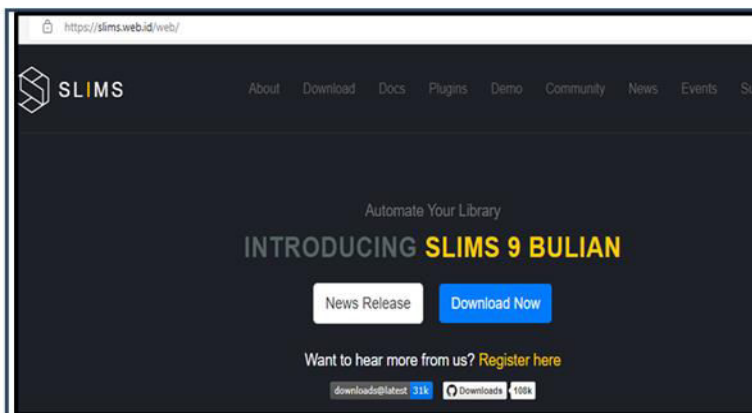

Fig.3 SLIMS Downloading

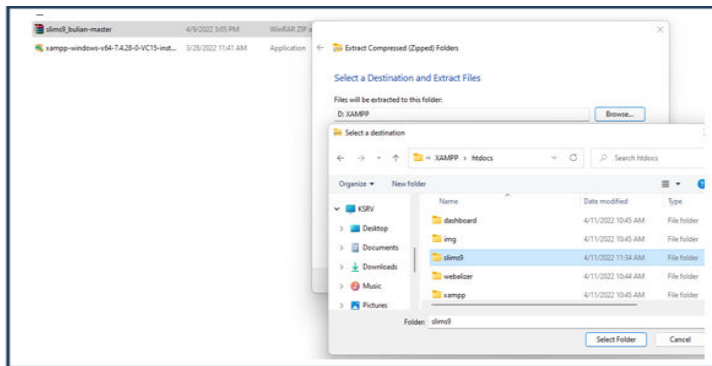

Fig.4 Extracting process

### Database Creation

Created a database in <http://127.0.0.1/phpmyadmin/webpage> as slims9.

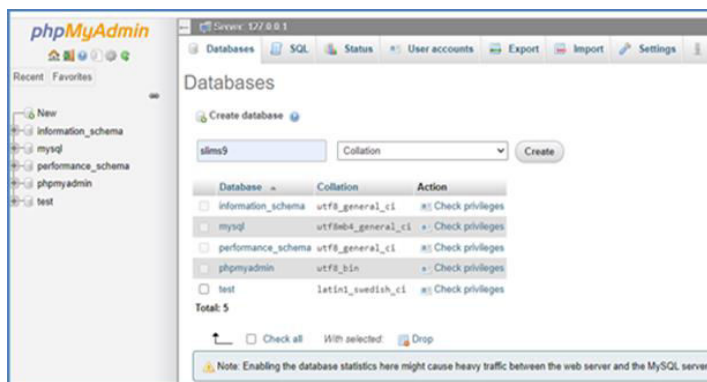

Fig.5 Creating a Database

### Installation Process

**Step: 1** By typing <http://127.0.0.1/slims9/> at browsers address bar and we can start the Installation process. Then click next

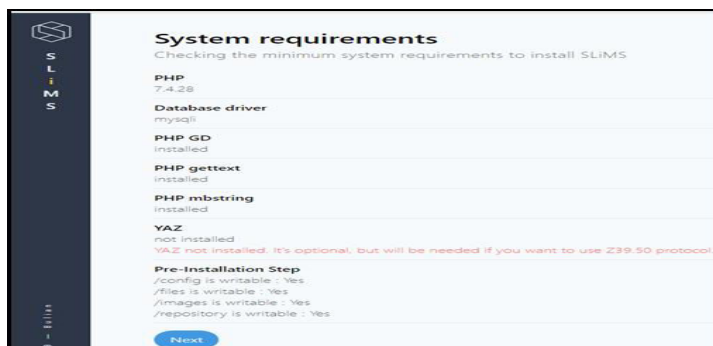

Fig.6 Checking requirements

**Step: 2** Fill Database Host, Database Name as slims 9, Database Username as root and Database Password

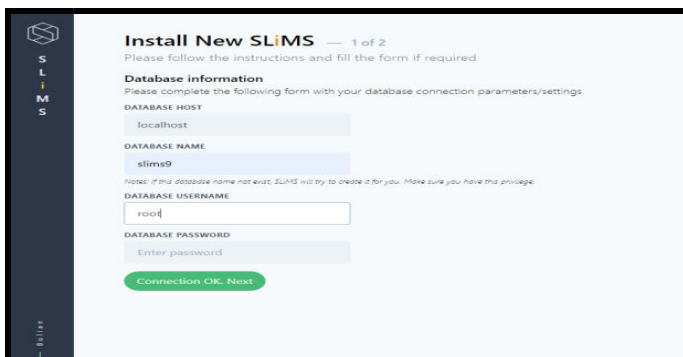

Fig.7 Database information

**Step: 3** Enter Username and password.

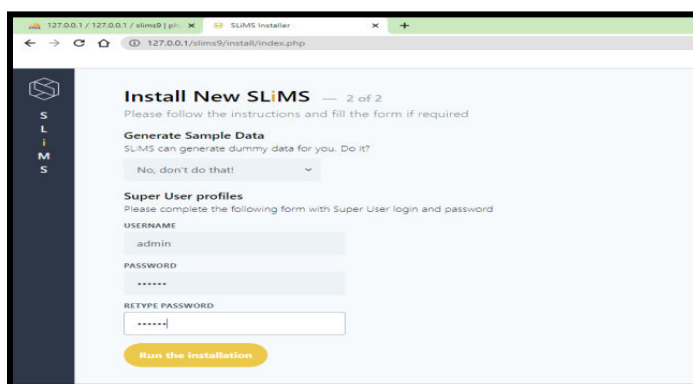

Fig.8 Setting Username & Password

**Final:** Our software installed successfully

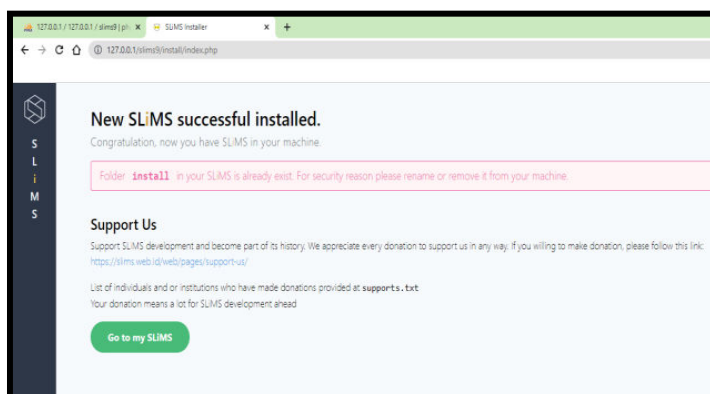

Fig.9 Installation completed

### SLiMS - Home page

This below screen shot shows that SLiMS home page, it have search tab and menus like information, news, help, Librarian, member area. The users can browse the menus to know the information's about Librarian, library events and its rules.

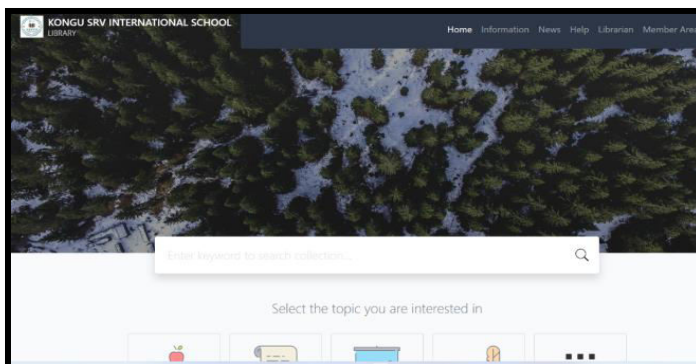

Fig.10 SLIMS - Home page

### OPAC

The below screen shot shows that the books can be searched by using the simple search option OPAC. Here by enter the keyword, search results can be received for any of the books with cover image.

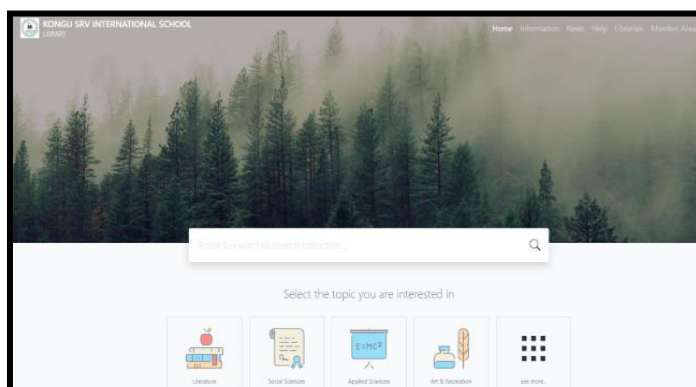

Fig.11 OPAC

### Advanced Search

SLIMS provides advance search option with Title, Author, Subjects, Location and Collection type etc. To get the exact result for the search

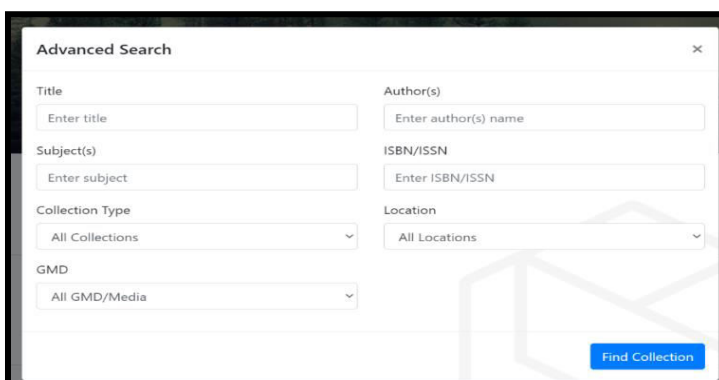

Fig.12 Advanced search

## Login Page

The below screen shot shows that the login page consist of user name & password user can give the login & password to access the SLIMS software.

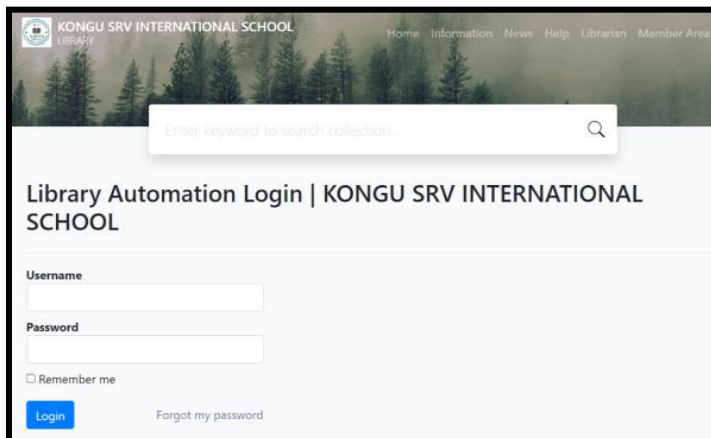

Fig.13 Login page

## Dashboard

SLIMS gives the different options for Admin login. The Dash Board has the feature of showing latest transaction, summery report such as new, return, extent and overdue details in graphic chart format and also gives the total collections, total item, lent and availability details.

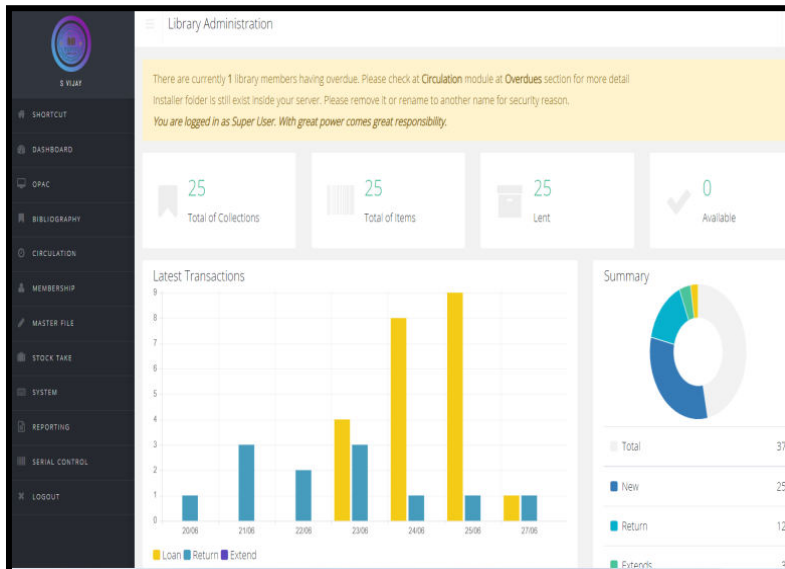

Fig.14 Dashboard

## Bibliography Module

The below screen shot shows that Bibliography module and it helps the librarians to add the bibliographical details by manual entry of MARC format and also it supports the Z39.50.



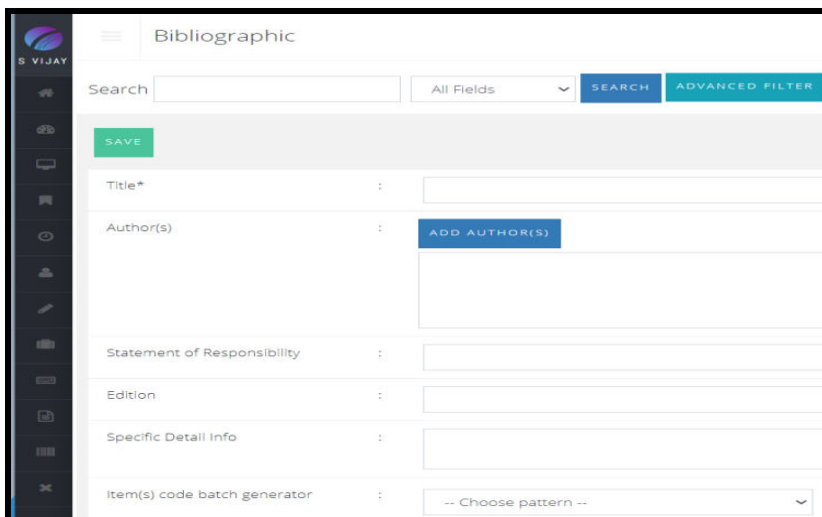

Fig.15 Bibliography Module

### Membership Module

SLIMS has a facility to create different kind of patron and set different privileges easily. To specify the Patron, a photograph of the Patron can be uploaded which can generate the Photo Identity Card of the Patron for Library and also enable the patron details bulk import and export in (CSV) file format.

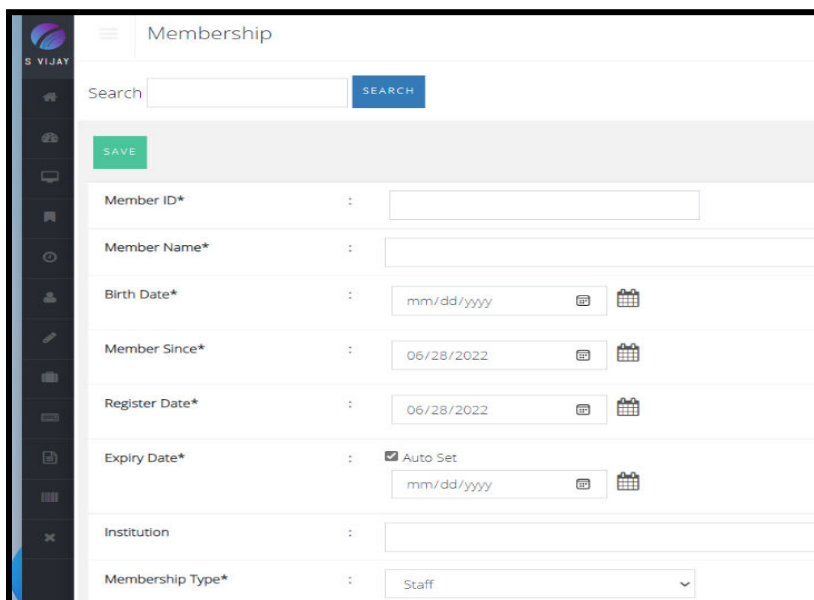

Fig.16 Membership Module

### Circulation Module

SLIMS circulation module provides the option of issue, return, renewal, loan history transfer, set library and fast cataloguing for easy access by the staff members.

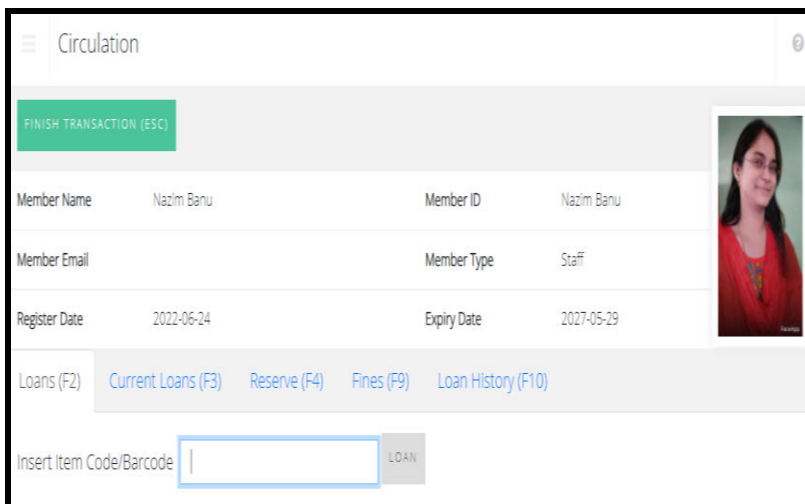

Fig.17 Circulation Module

**Master File**

This module gives information about the Authority file such as Content Type, Media Type, Publisher, Supplier and Subject details

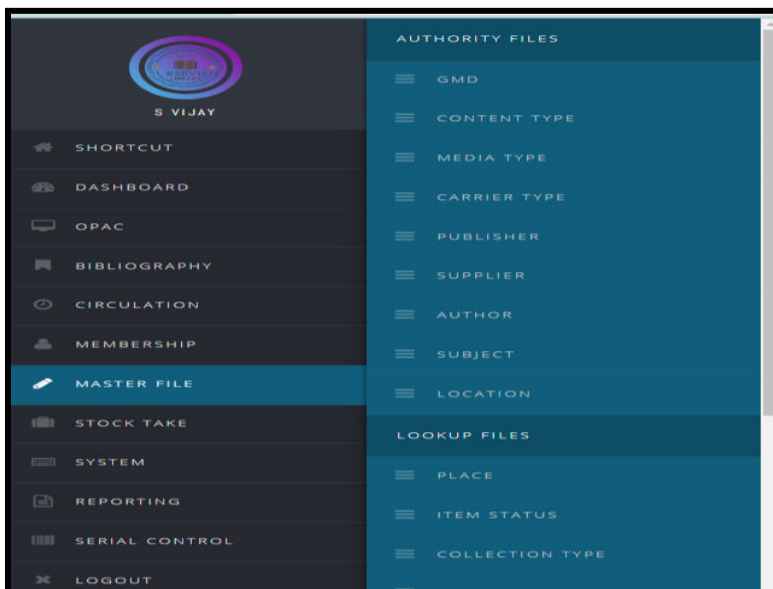

Fig.18 Master File

**System Module**

The System option is one of the powerful module of the SLIMS, which gives the facilities of various activities that are system configuration, system environment, theme, biblio indexes, modules, librarian system user, user group, barcode generation and system backup. The system module helps the librarian to administrate the SLIMS easily.

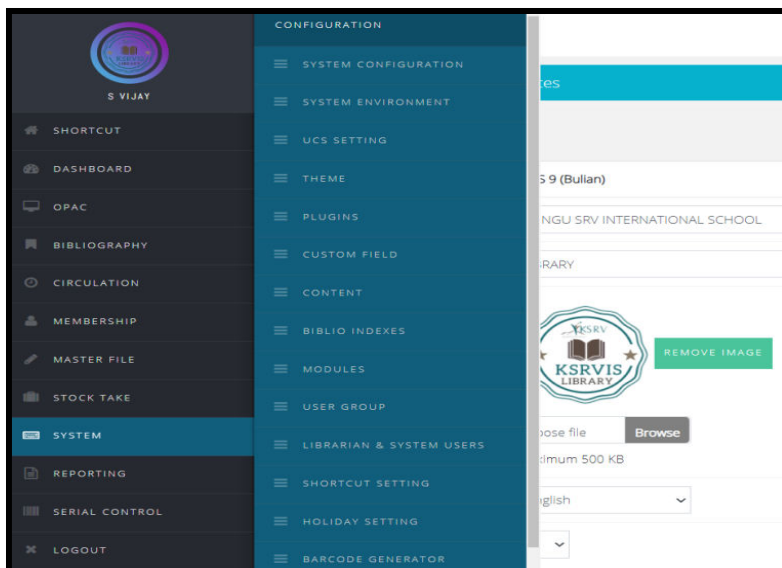

Fig.19 System Module

### Reporting

Generation of reports from the data stored in the database in a desired format is a great feature of SLIMS. There are three major reports and fifteen other reports are possible to generate by SLIMS and also can download the reports in excel and spared sheet format.

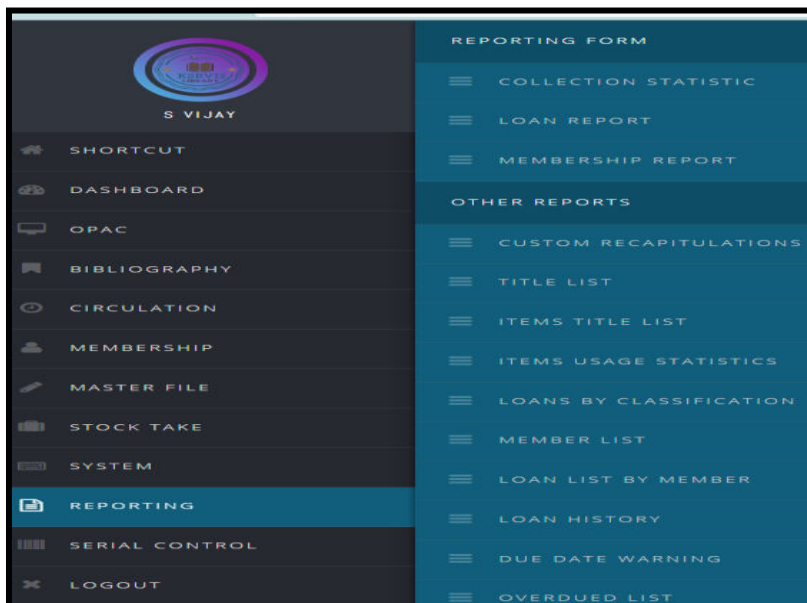

Fig.20 Reporting Module

### Serial Control Module

The serial control module in SLIMS helps to add subscription and cancel the subscription. It manages the serials in very effective way.

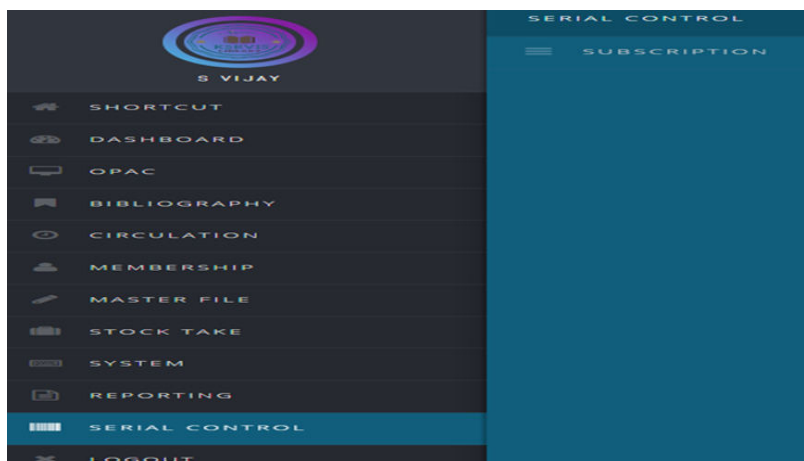

Fig.21 Serial control module

### Outcome of the Study

Based on this SLIMS implementation at Kongu SRV International school library the following are the outcome of the study

1. KSRVIS library collections are in a single database
2. It gives the full control over the library collections and operations
3. Teachers and students can check the required books by the OPAC
4. Users can get the complete details about the books for their further reading and research
5. Data entry of the books can be done through the downloading of bibliographic details from Library of congress and other catalogues.
6. The library OPAC connected in web environment for the wider reach.

### Conclusion

The Senayan Library Management System (SLIMS), an open-source solution, adds efficiency and modernization to library operations by providing a user-friendly platform with a variety of capabilities. The favourable effects seen, such as centralised collecting, increased control, and improved accessibility via web-based OPAC, highlight the practical benefits of SLIMS in educational settings. This study promotes the widespread usage of SLIMS in similar environments, highlighting its role in generating streamlined, automated, and user-centric library experiences.

### References

- [1] Chaudhary, A. (2015). Library Management System: An Open alternative. Conference cum Workshop on D Space Gandhinagar.
- [2] Jeyapragash, B., Rajkumar, T., & Muthuraj, A. (2019). SLIMS: An Open Source Library Management System. *Managerial Competencies for Library Professionals: Trends & Opportunities*, 166–175. <https://www.researchgate.net/publication/333311243>
- [3] Kongu SRV international school. (2023). KSRV LIBRARY. Retrieved January 03, 2024, from <https://ksrvlibrary.wixsite.com/read>
- [4] Senayan library management system (SLIMS) (2023). Retrieved January 03, 2024, from <https://slims.web.id/web/>
- [5] Tripathi, A., & Srivastava, A. (2012). Online Library Management System. *IOSR Journal of Engineering (IOSRJEN)*, 2(2), 180-186. [https://www.academia.edu/75605128/Online\\_Library\\_Management\\_System](https://www.academia.edu/75605128/Online_Library_Management_System)
- [6] Xampp. (2024), SourceForge. <https://sourceforge.net/projects/xampp/>

# The Use of Open-Source Software by Library Users in Private Universities in Ghana

Silas Adjei

Pentecost University, Ghana

E-mail: sadjei@pentvars.edu.gh

## Abstract

*This study explores the use of open-source software (OSS) by library users at Pentecost University (PU) and Central University (CU) with a focus on understanding library users ease of use, and barriers encountered. This study adopted the Technology Acceptance Model (TAM) as its framework. A descriptive survey design was employed and targeting registered undergraduate library users at both institutions. The findings revealed that CU and PU users found open-source software easy to use and interact with, contributing to a positive user experience. User-friendliness emerged as a critical factor influencing the extent of open-source software adoption. The study identified obstacles that impede the effective use of open-source software, including unreliable internet connectivity at PU and inadequate resources in support and training at CU. Hence, the library administration should adopt strategies and regulations to address the difficulties faced when utilizing Open Source Software, such as providing guidance, assistance, and instructional resources.*

**Keywords:** Open-Source Software, Library Users, Private Universities, Automation

## Introduction

Academic libraries stand as integral elements within higher education institutions, furnishing vital academic resources essential for teaching and learning. These libraries offer facilities that enable students and faculty to actively participate in research endeavors, fostering the expansion of their knowledge across various disciplines. Historically, library services and collections functioned without the reliance on Information and Communication Technology (ICT) tools and equipment. However, the current scenario has witnessed a transformation in this regard (Ayodele & Mohammed, 2019; Amekuedee, 2015). Consequently, libraries have transitioned from delivering conventional lending services to providing modern information services. The incorporation of Information and Communication Technology (ICT) into library operations has brought about a profound transformation in the execution of library services in the 21st century. Presently, the internet, electronic resources, and computer software have significantly improved information services (Agrawal, 2015). Ayodele and Mohammed (2019) observed that the incorporation of computerization in libraries led to the emergence of library application software packages. Open-source library management systems (OSLMS) have gained growing popularity in recent times, offering library professionals a variety of advanced functionalities. Nevertheless, the extensive adoption and utilization of Open Source Learning Management Systems (OSLMS) are still in their initial phases in numerous global regions, particularly in Africa. An advantage of open-source software lies in its perpetual development and frequent updates, facilitated by the active participation of the community. Although certain external agencies offer technical assistance for open-source software, the market is still predominantly controlled by commercial software (Gangadhar, Nagaraja, & Vasanthakumar, 2017).

Open Source Software is not widely adopted in many educational institutions throughout Africa, including Ghana. The inadequate utilization of library software can be ascribed to inadequate funding, restricted adoption of cutting-edge technology, a dearth of expertise among library personnel, and irregular power supply (Tetteh, 2019). Numerous research endeavors (Dei and

Citizen 2022; Uzomba, Oyebola, & Izuchukwu, 2019; Raghunadha and Kumar 2019) have examined the usage of open-source software by library users in public academic institutions. However, there is a dearth of research that specifically concentrates on private academic institutions.

Open-source software (OSS) offers a multitude of advantages, such as easy retrieval of information, efficient storage and organization, cost-effective access to vast amounts of information, efficient distribution of information, seamless updates, strong search capabilities, portability, and the ability to handle large amounts of data. These advantages, as highlighted by researchers such as Amjad, Ahmed, & Naeem (2018), Bhatia (2015), Bin (2016), Ansari & Zuberi (2018), and Nazir (2015), contribute to the increasing adoption of OSS in academic libraries and its role in reshaping the library concept from physical repositories to platforms for accessible information.

Although open-source software offers numerous benefits for academic libraries, there has been a lack of focus on its utilization by library users in private universities. Thus, the objective of this research was to assess the use of Open Source Software (OSS) by library users in private universities in Ghana. The focus was on the perceived ease of use, and the challenges they faced when using OSS. This study aims to furnish Pentecost and Central University with insights into the extent of open-source software utilization among library users. The study's findings, along with corresponding recommendations, will be conveyed to the directors of the Pentecost and Central University Libraries.

### **Objectives of the Study**

1. To determine the perceived ease of use of open-source software among library patrons at Pentecost and Central University.
2. To determine the obstacles that impede library users at Pentecost and Central University from using open-source software.

### **Literature Review**

#### **Open-Source Software (OSS)**

Open-source software emerged in the 1980s, pioneered by Richard M. Stallman, a software developer based at the Massachusetts Institute of Technology (MIT). Stallman played a crucial role in establishing the groundwork for the open-source movement. After 13 years of his contribution to MIT, in 1984 he decided to resign from MIT, as he wanted to create something different for people who could not afford to buy costly software, called commercial or proprietary software. He started the project called "GNU (GNU's not UNIX)", as a contribution to society. He changed the idea of programmers at that time since he decided to give the source code with his software, which was a total shock for the commercial software developers since their code was never made public and they were even paid for a single change (Stallman, 2002).

#### **Perceived Ease of Use of Open-Source Software**

Upasani (2016) states "that modern libraries need to stay technologically active to provide different value-added services to their research community. Private academic libraries need to hold library management systems and digital technologies as smart tools for providing advanced services to their users. According to the author, private academic libraries should collaborate with computer experts to become technologically sounder in using OSS. Here the author also provides an overview of the benefits, limitations, and availability of different open-source library management systems in the Indian context." Vijayakumar *et al.*, (2016) discovered that private academic libraries currently rely solely on Information and Communications Technology (ICT) to

deliver various services to their users. The widespread adoption of open-source software was considered favorable due to its perceived benefits. Building on these findings, Baeza-Yates and Ribeiro (2011) assert that Asian governments view open source as a tool to stimulate their economies and drive technological progress in the region. The results indicated that a majority of library staff members utilized open-source software. According to Bola, Olanyi, and Oyekorke (2013), the main goal of university education is to develop a comprehensive intellect that can engage in independent learning and research. Before the implementation of Information and Communications Technology (ICT) for the gathering, organization, and distribution of information, universities were constrained by the availability of resources solely within their libraries or through inter-library loans when it came to research, teaching, and learning.

**Barriers that hinder the use of Open- Source Software**

Examining open source from a comprehensive and critical perspective should prompt inquiries about potential disadvantages. Open-source software has faced numerous criticisms. Sathesh (2012) identified three significant constraints of open-source software, which are as follows: “No or less personal support, thusly, less customer-friendly i.e. All the features expected by the user may not be available. Similar findings were found in the works of Maltikarjun (2011) who explored Open Source software. Also, lack of training, due to lack of training and expertise on Open Source software may lead to ineffective utilization of the software and Maintenance and troubleshooting of a particular OSS needs specialized skills and knowledge about that software. It supports the research by Aswath (2015) in which it was indicated that adequate training is a prerequisite for the success of open source software movement among working professionals. It is also one of the risk factors that how to train the library staff on operational modules of open-source software. It includes updating new versions too. Continuous training support is required to cope with the new versions and technology. This finding was in congruence with the works of (RajKumar & Krishnan, 2011). Need for technological sophistication such as higher labour costs, Lack of scalability fewer advanced features, nobody is responsible (by contract) also in agreement with (RajKumar & Krishnan, 2011).”

**Theoretical Framework**

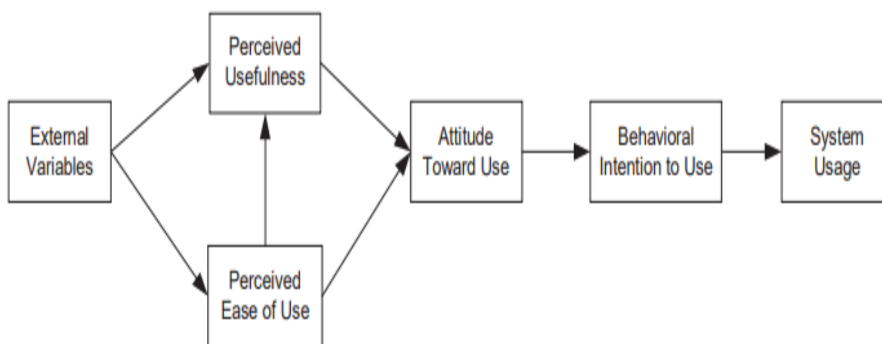

Fig.1 Technology Acceptance Model

**Methodology**

The study utilized a descriptive survey research design. The researcher chose a descriptive survey as the appropriate methodology for this study, as it allowed for a precise depiction of the

utilisation of open-source software by library users in private universities in Ghana. Turkson (2011) proposes that quantitative research methods can be employed by researchers when conducting a descriptive survey. Therefore, questionnaires were utilized to collect data for this study. The study specifically targeted the library users of Pentecost and Central University Library (Miotso Campus). The rationale for choosing this specific population is the shared characteristic of being privately-owned academic libraries, namely Pentecost and Central University, which have both adopted open-source software for resource management. The number of undergraduate students at the two universities is as follows: PU (609) and CU (531), resulting in a combined total of 1140. In the context of this specific research, given constraints related to time and available resources, the researcher chose twenty-five percent (25%) of the population for sample size based on Nwana's (1992) as cited in Kuranchie (2016) assertion that a population of few thousand, 25% sample size is chosen from the target population. Therefore, the sample size for the students was 285. The researcher utilized the simple random sampling technique to choose the participants.

A questionnaire was chosen as a method to optimize efficiency and minimize expenses, given the substantial number of respondents. The questionnaire was formulated in alignment with the study's objectives. The quantitative data collected were analyzed using the Statistical Package for Social Sciences (SPSS) version 25.0 through statistical analysis. The findings were presented using various statistical measures such as frequencies, percentages, tables, and bar charts. The factors were ranked to identify the factors that library users in both institutions consider as most important to those they consider as least important. To do this, the data was analyzed using the Friedman test. The test is used when the intention is to arrange several variables based on their importance or rank (Pallant, 2010).

## Data Analysis and Findings

### Bio Data of Respondents

This section comprises the gender, age range, and level of study. This facilitates the discernment of the participants' demographic profile, aiding in understanding the composition of the study.

#### Gender of Respondents

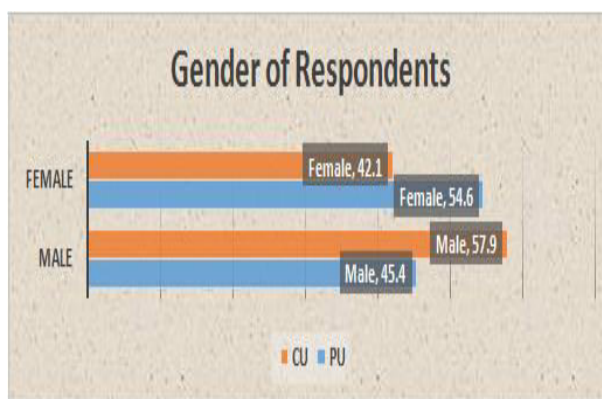

Fig.2 Gender of respondents

Fig.2 depicts the gender distribution of respondents. At Pentecost University (PU), there were a total of 152 respondents. Meanwhile, at Central University (CU), there were 133 respondents, among which 77 respondents (57.9%) were male. This indicates that the majority of library users at Pentecost University were females while the majority of library users at Central University were male as compared to females' library users.



### Age of the Respondents

TABLE I AGE OF RESPONDENTS

Age of Respondents	PU N=152		CU N=133		Total N=285	
	no	%	no	%	no	%
18- 20 years	20	13.1	13	9.8	33	11.6
21- 23 years	84	55.3	67	50.4	151	53.0
24 -26 years	45	29.6	48	36.1	93	32.6
27 years and above	3	2.0	5	3.7	8	2.8

Source: Field data, 2023

At Pentecost University (PU), a significant majority of 84 respondents (55.3%) fell within the age range of 21-23. Out of the 133 respondents from Central University (CU), the largest age group was again the 21-23 range, with 67 respondents (50.4%) falling within this category. These results highlight that the majority of library users at both Pentecost and Central University, who took part in the study, are within the 21-23 age range.

### Levels of Study of Respondents

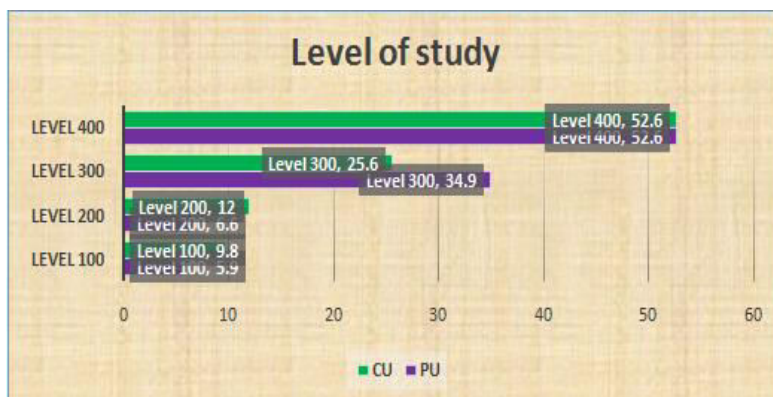

Fig.3 Level of study

At Pentecost University (PU), 80 respondents (52.6%) were at the 400 level. Among the 133 respondents from Central University (CU), the largest group was also at level 400, with 70 respondents (52.6%) in this category. This analysis indicates that the majority of library users who participated in the study, both from Pentecost and Central University, were predominantly at level 400 of their studies.

### Perceived Ease of Use of Open Source Software by Library Users

The first objective of the study is to determine the perceived ease of using open-source software by library users in PU and CU.

The findings of the study indicate that library users in the two institutions reported that the open-source software in the library is highly user-friendly. According to the study, library users of the two institutions libraries identified “user-friendly” as the most significant attribute of open-source software in the library. The perception of open-source software as user-friendly and engaging by library patrons suggests that it enhances their overall user satisfaction.

TABLE II FRIEDMAN TEST RANKS

Ease of use	PU N=152 Mean rank	CU N=133 Mean rank	Chi- squared	Degrees of Freedom	Significance
The open-source software available in the library is designed to be easily used by individuals.	2.87	2.27	6.9570	3	.0000
The use of the OPAC (online catalogue) is easy.	2.40	2.23	4.9109	3	.0004
Accessing information from the institutional repository is easy.	2.02	2.58	2.9202	3	.0000
The library open source software provides adequate information on what I need	2.17	2.20	7.5897	3	.0003
The open-source software available in the library is designed to be easily used by individuals.	2.23	2.01	3.2848	3	.0101

### Major Barriers to the Use of Open-Source Software

Every software has unique limitations that need to be resolved to ensure maximum efficiency and effectiveness. Table III outlines the barriers that hinder the use of open-source software among library users in Pentecost and Central University.

TABLE III BARRIERS TO THE USE OF OPEN-SOURCE SOFTWARE

Barriers	PU N=152		CU N=133		Total N=285	
	no	%	no	%	no	%
Unstable internet connectivity	134	88.2	117	88.0	251	88.1
Lack of support and training	132	86.8	120	89.5	252	88.4
Lack of time	131	86.2	114	85.7	245	86.0
I lack searching skills	125	82.2	97	72.9	222	77.9
Lack of supervision	119	78.3	51	38.3	170	59.6
Lack of Technical Support	111	73.0	30	22.6	141	49.5
Unstable power supply	105	69.1	12	9.0	117	41.1
Lack of user-friendly interfaces	7	46.7	2	1.5	9	3.2

\*Multiple-choice responses,  
Source: Field data, 2023

As shown in Table III, 134 PU library users (88.2%) indicated that unstable internet connectivity on campus is a significant barrier to using open-source software in the Pentecost University library. Concerning library users in Central University (CU), 120 respondents (90.2%) indicated that the lack of support and training is a significant barrier hindering the use of open-source software in the Central University library. The study found that among library users at CU, the primary obstacle impeding their use of open-source software is the absence of support and training. This means that users at CU Library encounter challenges related to receiving the necessary assistance and training needed to effectively use open-source software in their library activities.

## **Discussion of Findings**

### **Perceived Ease of Use of Open Source Software by Library Users**

The findings of the study suggested that library users in both establishments expressed that the open-source software in the library is user-friendly, followed by the easily navigable OPAC (online catalogue), and then the convenience of accessing information from the institutional repository. This finding aligns with the research conducted by Dei & Tetteh (2022), which demonstrated that the user-friendliness of a software or programme significantly influences its adoption rate. Regarding the Technology Acceptance Model (TAM), if a system is user-friendly, there is a likelihood that users will utilize it more frequently. Similarly, if the open-source software (OSS) utilized by library management is easy to use, its usage will probably expand (Davis, 1989).

### **Barriers to the Use of Open Source Software**

The research findings revealed that a substantial portion of library users in both institutions experienced challenges when using open-source software. The library users at PU expressed that an unstable internet connection was a significant obstacle. Furthermore, library users in CU commonly encountered the challenge of insufficient support and training when utilizing open-source software. The issue of inconsistent internet connectivity on campus poses a substantial hindrance for library patrons at PU who wish to utilize open-source software. This corresponds with the results of Okewale and Adetimirin's (2011) study, which emphasized the diverse obstacles encountered by libraries when adopting open-source software and other technologies, such as poor internet connectivity. Nevertheless, the results of the study conducted by Ncube (2015) corroborated the fact that most students dedicate over 18 hours per week to internet usage. This implies that library users tend to postpone information retrieval and the utilization of open-source software for different purposes.

## **Conclusion**

Library users in both institutions found open-source software easy to use and interact with, contributing to a positive user experience. The level of open-source software use is significantly influenced by user-friendliness. Although open-source software offers numerous benefits, there were obstacles related to its implementation in the library's operations and services. The library users in PU reported that unstable internet connectivity was a significant challenge. Furthermore, library users in CU commonly encountered the challenge of insufficient support and training when utilizing open-source software. Nevertheless, the results also indicated that inadequate oversight, insufficient technical assistance, and limited ongoing training on the utilization of the open-source software (OSS) were the minor obstacles impeding library users in both establishments. Failure to address these challenges will prevent library users in both institutions from fully capitalizing on the advantages of utilizing open-source software in libraries.

## **Recommendations**

The findings of the study informed the following recommendations for addressing the challenges faced by library users in both institutions:

1. It was found that unstable internet connectivity on campus was a barrier that hindered the use of open-source software by library users in PU. Therefore, the management of the PU library can implement a local server system that stores frequently accessed data and resources. This localized approach will reduce dependence on external internet speeds for routine tasks, ensuring that users can access essential information quickly and efficiently even when the overall internet connectivity is slow. This strategy can be complemented by encouraging users

to download essential materials during periods of higher internet speeds, enabling offline access and reducing reliance on real-time connectivity for certain resources.

2. The study found that lack of support and training was another barrier that hindered the use of open-source software by library users. Therefore, the management of the CU library should establish ongoing support and training programs for library users at both institutions. This is particularly crucial for CU Library, where a lack of support and training was identified as a challenge. Regular training sessions will help users stay updated on software features and overcome any usability challenges.

## References

- [1] Agrawal, P. (2015). Open source software and open access resources for enhancing library services: an exploratory study.
- [2] Amekuedee, J. (2015). Evaluation of library automation in some Ghanaian university libraries. *The Electronic Library*, 23(4), 442-452.
- [3] Ayodele, R., & Mohammed, Z. (2019). Application software packages for library operations and services in federal university libraries, Nigeria. *Nigerian Libraries*, 49(2).
- [4] Bola, O., Olanyi, O., & Oyekorke. (2013). Accessibility and utilization of open source software by graduate students in the University of Lagos, Nigeria. *Information Journal of Humanities and Social Science*, (2) 17. 62-68.
- [5] Dei, D.-G., & Tetteh, C. (2022). Adoption and Use of Open-Source Software in Academic Libraries in Ghana. *Ghana Library Journal*, Vol.27 (1) p.1-133.
- [6] Gangadhar, K., Nagaraja, A., & Vasanthakumar, M. (2017). Present Library automation status: open source Library software opportunity or threat. *International Journal of Library & Information Science (IJLIS)*, 6(1), 56-66.
- [7] Raghunadha, T., & Kumar, K. (2019). Open source software's and their impact on library and information centre: An overview. *International Journal of Library and Information Science*, Vol. 5(4), pp. 90-96.
- [8] Rajkumar, J., & Krishnan, V. (2011). Use of Open source software in Libraries: a view, In *Open source software and Libraries* Edited by Baby Valsala C.P & *et al.*, (Role of Open source software in Libraries: Proceedings). 13-17.
- [9] Stallman, R. (2002). Free software foundation, for supporting development and spreading of information of the GNU project. Retrieved from <http://www.fsf.org>.
- [10] Tetteh, C. (2019). Use of Open Source Software in Academic Libraries in Ghana: A Case Study of Sam Jonah Library, University of Cape Coast. (MA dissertation, University of Ghana).
- [11] Upasani, O. (2016). Advantages and limitations of open source software for library management system functions: The experience of libraries in India. *The Serials Librarian*, 71(2), 121-130.
- [12] Uzomba, E., Oyebola, O., & Izuchukwu, A. (2019). "The Use and Application of Open Source Integrated Library System in Academic Libraries in Nigeria: Koha Example". *Library Philosophy and Practice (e-journal)*, 1250.
- [13] Zeki, S., & Abubakar, A. (2021). Perceptions of library and information science community towards open source software adoption in libraries of Oman. *Computer Science, Education*, 4(12) 51-53.

# Data Visualization Tools and Techniques: An Overview

**Dr. Pronobi Porel<sup>1</sup> and Dr. Swapan Khan<sup>2</sup>**

<sup>1</sup>Librarian, Rabindra Mahavidyalaya, Champadanga, Hooghly, West Bengal, India

<sup>2</sup>Librarian, Narasinha Dutt College, Howrah, West Bengal, India

E-mail: kxanpronobi@gmail.com, kxanswapan@gmail.com

## Abstract

*The present study focuses on some aspects of data visualization tools. The primary advantages of data visualization tools to the decision makers are to find out information more easily than conventional textual reports. This study highlights the importance and types of various data visualization tools. It shows common visualization tools with their special features. Selection of right tools by the users is most important. Some important factors that must be checked at the time of selection are highlighted in this study. Dashboard that is most important in data visualization tools is discussed in this study elaborately.*

**Keywords:** Data visualization, research outcome, data analysis, data analysis tools, visualization tools.

## Introduction

Researchers need to evaluate and select the best data visualization tool to communicate key data findings to users or readers with efficient, highly visual storytelling techniques (Lawton, June 2, 2022). The most common data visualization tools are available in both free and paid version. Researchers have to select appropriate one after analyzing their needs. The advent of Information and Communication Technology (ICT), today, make this research visibility simple by the application of numerous data visualization tools and techniques. In academic research, research visualization serves as a powerful communicate tool that explore research findings and make it accessible to all. Present study focuses on the research data visualization by using various tools and techniques available in both online as well as offline mode. There are great opportunities for implementing and also future research in data visualization. The study will emphasize on the benefits of data visualization to the researchers, implementing agencies and academic scholars also.

## Objectives of the Study

Data visualization of research outcomes is an important aspect of research outcomes for implementation. "Data visualization deals with how to present data, to the right people, at the right time, to enable them to gain insights most effectively" (Karpagavalli, 2020). The main objectives of this study are as follows:

1. to know the basics of data visualization;
2. to state the various software applications;
3. to identify the criteria for selecting best applications;
4. to understand Dashboard in realm of data.

## Review of Literature

Data visualization is crucial in every sectors of the world, which has been widely used for helping decision making process (Qin, Luo, Tang & Li, 2020). Many studies have found on various areas of data visualization. Midway (2020) introduced ten principles of effective data visualization that serve as guidance for authors to improve their visual message. Data visualization is the representation of data in visual form. It provides a powerful means both to make sense of data and

to then communicate (Few & Edge, 2007). A study has been completed on uncertainty in data visualization to explore why uncertainty visualization is hard (Brodie, Allendes Osorio, Lopes, 2012). Application of data visualization is seen in many sectors. Healy & Moody (2014) studied about visualizing data is central to social scientific work. Zhu (2007) studied to find out the meaning of effective visualization and measuring of it. In his study, he pointed out the problem that affected the design and evaluation of visualization. Inastrilla (September, 2023) addressed the importance of data visualization in modern society. An important study has been done on data visualization for student's perceptions about their learning (Fitri, Muhammad, Riki & Sampath, 2023). The present study shows various aspects of data visualizations for information professionals and young researchers.

## **Data Visualization**

### *1. Definition*

Data visualization is the representation of data, more importantly, process of transforming data into visual forms, such as charts, plots, graphs, maps, and even animations in such a way that visual displays of information is easy to understand (Coursera, November 29, 2023). In simple words data visualization is the graphical representation of information and data. Data visualization tools help an accessible way to visualize and understand relationships, trends, patterns of data. In the world of Big Data especially for unstructured data analysis, these visualization tools are essential to analyze massive amounts of information.

### *2. Types of Data Visualizations*

It is very important to select the appropriate graph or chart for research data visualization. Some common factors must keep into mind at the time of selection like purpose, type of data and context of data. The common visualization techniques include tables, pie charts, bar charts, line and area charts, histograms, heat maps, scatter plots, tree maps etc.

## **Importance of Data Visualization**

In the realm of data, "A picture is worth a thousand words" expresses the importance of data visualization. Data visualization plays a significant role of presenting research findings that goes beyond numbers and statistics. The importance of data visualization may be described as below:

*1. Better Understanding of Findings:* Data visualization increases the understanding and interpretation of research outcomes. In most of the cases raw and unstructured data is beyond of understanding or meaningful outcomes. Main objectives of research outcomes are to find patterns, trends and relationships (e-Content Pro., July 13, 2023). Without visualizing data most of the users or implementing agencies may over look the actual results even sometimes it may go unnoticed to the researcher.

*2. Understandable Complicated Areas:* Many of cases inner thought of the research output or a part of research outcome is beyond of understandable especially in case of relationships among factors or components. It is very difficult to understand from textual descriptions of the outcomes. Data visualization simplifies all of the complications of underlying information.

*3. Increasing Engagement and Retention:* Visual outputs of research activities convey information more efficiently as human brains process visual information quickly and efficiently. Moreover human brains create a lasting impact on readers and fostering a deeper understanding of the research presented. Therefore, data visualization of research outputs become more engaging and memorable (e-Content Pro., July 13, 2023).

4. *Improves Decision Making*: Data visualization helps to take any decision from the research outputs. Generally data visualization improves decision making in four ways e.g. increase speed, simplify communication, improve accuracy and empower collaboration. It depicts actionable insights from huge amounts of data in little bit of time. Decision making from unstructured data is very difficult to take fruitful decisions timely. In this case visual representation is essential that presents data in a consumable form (Ingram, 2019).

**Benefits of Data Visualization**

1. Data visualization solves data insufficiencies and minimizes the data complexity
2. It can easily identify errors laying in data and also highlights inaccuracies.
3. Data visualization gear up the decision making process
4. Some of the software acquire real-time data and analyze in real-time basis.
5. It explores business insights and achieves goals in right way.
6. Data visualization guides to rectify, if needed, observing the data trends.
7. It can be used to supply instant demand of optimize report to the authority
8. Data visualization promotes storytelling and conveys the true message to the users.

Without data visualization, any organisation would have to spend huge time for decision making by using textual reports.

TABLE I TOOLS AND SPECIAL FEATURES

S. No.	Tools	Availability	Special features
1	ChartBlocks	Both free and paid version	Import data from anywhere including from live feeds
2	Chartist.js	Free and open-source but limited support	highly customizable, light weight and cross-browser compatible
3	D3.js	Free and open-source but support available than with paid tools	Powerful, customizable and huge number of chart types
4	Datawrapper	Both free and paid version	Specifically designed for newsroom data visualization
5	deck.gl	Free and open-source	Easy-to-use 2D and 3D data visualizations
6	Dundas BI	Built on a open API platform Paid version	Integrate with multiple platforms, highly secure
7	ECharts	Free and open-source	Multi-dimensional data support, abundant chart types
8	FusionCharts	Paid	Wide range of interactive charts & maps and powerful charting solutions
9	Google Charts	Free but limited support	Works with dynamic data, requires no plugins
10	Grafana	Free and open-source but cloud-hosted version is payable	Supports over 50 data sources via plugins
11	Infogram	Nasic version is free	Intuitive WYSIWYG editor that converts users' data into infographics
12	Power BI	Both free and paid license	Automatic data refresh, scheduling, ability to create apps and workspaces, robust security and governance
13	Sigma.js	Free and open-source	Highly customizable and extensible, network graph
14	Tableau	Tableau Public is a free platform	Offline and online mode version
15	Vega	Free and open-source	Customize visualizations across large datasets, itself as “visualization grammar”

## Data Visualization Tools

Data visualization has been using long years ago when the people draw the pictures to understand the quantity of things. "The earliest form of data visualization can be traced back the Egyptians in the pre-17<sup>th</sup> century, largely used to assist in navigation" (IBM, n.d.). Data visualization tools are software applications that transform data in easy understandable visual form. A good and efficient data visualization tool helps people to take data-driven decisions effectively. There are plenty of data visualization tools available in the market. Some of them are open source and others are paid software. The following are most popular software applications:

### Choosing the Right Data Visualization Tools

Selecting a right data visualization tool is a difficult job for the best fit of the data, audiences, objectives and the needs. It is very crucial to remember diverse of aspects at the time of choosing right tools. Some guidelines may help in this regard such as:

#### 1. Flexible Data Visualizations

Tools must be capable to display all types of representations by using various types of data. In organisation both type of data – structured, semi structured and unstructured data are found. It must be assure that the selected tools adopt all types of data. It must also be adaptable enough to create all kinds of representations needed for data analysis (Robin, n.d.). It must be perform exploratory analysis, regression analysis, factor analysis, cluster analysis, hierarchical clustering correlations between variables and so on.

#### 2. User Interface

Selected visualization tool must have good user interface that allows non-technical users to operate easily. It guides to users in control over details, customization, and functionality. Interface must be in responsive for all types of devices.

#### 3. Data Storytelling

Visualization tools must have capabilities to communicate data with images so that it conveys message or insights to target users and tells them the full story. It must be effective to produce:

- a. interactive graphs
- b. 2D/3D visualizations
- c. images integration etc.

#### 4. Ability to Handle Big Dataset

Visualization tools must be able to handle big dataset. It has the ability

- a. to handle very large amounts of data
- b. to visualize big data sets
- c. to store vast data

#### 5. Scope of Integration

The tools have the scope of integration of external applications such as:

- a. Embed interactive widgets
- b. Connect to APIs
- c. Plug-in integration
- d. Access third party libraries
- e. External database connection etc.



### 6. *Machine Independent and Cross-Browsers Platform*

Cross-platform applications run across multiple computer platforms, even in offline and cross-browser applications are capable of running in several browsers. Visualization tools must be capable to browsers based activities such as:

- a. Share data via email
- b. Link to external websites
- c. Publish data to web pages
- d. Interactively showing data
- e. Export reports in various file formats

### 7. *Network and Real Time Analysis*

The tools have the option for network analysis visually. Some of the cases live data analysis is required; in that case the tools must have the scope of:

- a. view live data streams
- b. display real-time data
- c. view data over time and
- d. collaborative activities etc.

### 8. *Other Factors*

There are some other factors to choose right visualization tools such as:

- a. Price of the product
- b. Open source/free software
- c. Back support service
- d. Whether knowledge of software is required or not
- e. Stability
- f. Security etc.
- g. Data transformation facilities

## **Introducing Dashboard**

A dashboard is a deliberate collection of data visualizations, organized onto one screen. It shows key information visually and/or numerically at a glance without the need for extensive interactivity. It helps to take decision with a high-level view of most important metrics (Ingram, October 12, 2022). Usually, a dashboard is used to convey different types of information but all the information are related to each other. "A dashboard is an easy to read, often single page, real-time user interface, showing a graphical presentation of the current status (snapshot) and historical trends of an organization's or department's key performance indicators to enable instantaneous and informed decisions to be made at a glance" (Karpagavalli, 2020).

## **Types of Dashboards**

All most all of the data visualization tools provide predefined Dashboards. Some of the applications provide scope to customize Dashboards as per requisitions of the users. On the basis of utility it can be categorized into four types such as:

- a. Strategic Dashboards
- b. Analytical Dashboards
- c. Operational Dashboards
- d. Informational Dashboards

### Examples of Dashboards

Google Analytics: It is one type of Dashboard that collects raw data from concerned websites and mobile applications and creates reports.



Source: <https://dashthis.com/blog/data-visualization-dashboard-examples/>  
 Fig.1 Google Analytics

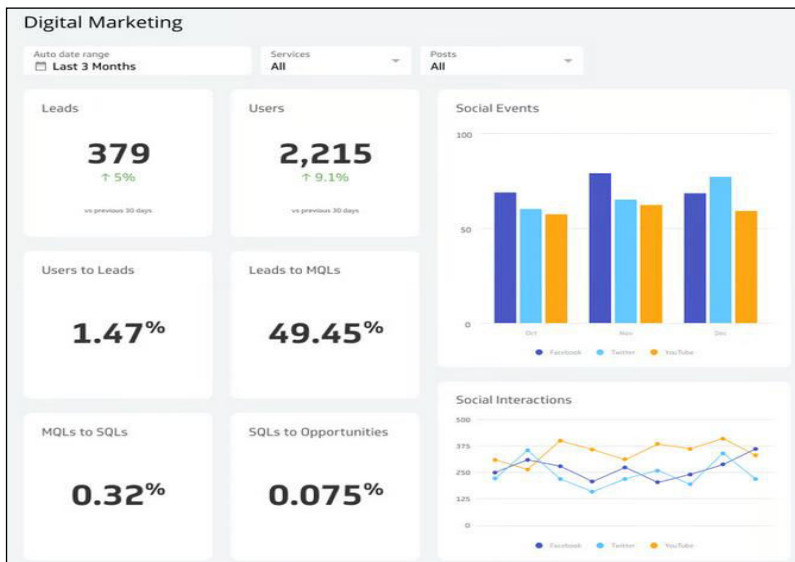

Source: <https://www.klipfolio.com>  
 Fig.2 Digital Marketing Dashboard

### Importance Dashboard in Data Visualization Tools

Dashboards are centralized visualization of aggregated data and in most of the cases it performs in real-time basis. Centralized view always provide quick and clear picture of huge and complex data sets. Real-time updates make the decisions in right way as real-time monitoring is possible at that

time. Since they're dynamic, Dashboards help and enhance the decision making process promptly that results increasing productivity (Saravana, January 10, 2024).

### **Conclusion**

As per MIT neuroscientists the human brain can process an image as little as 13 milliseconds (Trafton, January 16, 2014). This study supports research conducted by University of Minnesota, which found that our brains process visuals 60,000 times faster than text (Wong, n.d.). In this digital era every organisation captures vast amount of data from heterogeneous source that needs to analyze for decision making process fast and promptly. Textual report, which is less understanding by human brain quickly, is unable to help users to take decisions in right time from vast amount of dataset. "Data visualization matters because it brings complicated concepts to life" (Perkins-Munn, March 8, 2023). Data visualization tools solve this crisis easily and efficiently. These tools are, today in social media age, integral part of every sector especially in Information Technology, education, business and health sector. At the time of doing research, sometimes huge amount of data are manipulated. Researchers are also required to use data visualization tools for better research outcomes and sharing of results among others related stakeholders.

### **References**

- [1] Brodlie, K., Allendes Osorio, R., & Lopes, A. (2012). A review of uncertainty in data visualization. *Expanding the frontiers of visual analytics and visualization*, 81-109.
- [2] Cameron Chapman, C. (n.d.). A Complete Overview of the Best Data Visualization Tools. Retrieved December 28, 2023 from <https://www.toptal.com/designers/data-visualization/data-visualization-tools>
- [3] Coursera. (November 29, 2023). Data Visualization: Definition, Benefits, and Examples. Retrieved December 11, 2023 from <https://www.coursera.org/articles/data-visualization>
- [4] eContent Pro. (July 13, 2023). The Importance of Data Visualization in Presenting Research Findings. Retrieved December 21, 2023 from <https://www.econtentpro.com/blog/importance-of-data-visualization-in-presenting-research/281>
- [5] Few, S., & Edge, P. (2007). Data visualization: past, present, and future. IBM Cognos Innovation Center, 1-12.
- [6] Fitri, S., Muhammad, T., Riki, C., & Sampath, S. (2023). Data Visualization for Students' Perception Toward Online and Offline Learning in Information Technology Education Program. *International Journal of Quantitative Research and Modeling*, 4(3), 178-184.
- [7] Healy, K., & Moody, J. (2014). Data visualization in sociology. *Annual review of sociology*, 40, 105-128.
- [8] IBM. (n.d.). What is data visualization? Retrieved November 2, 2023 from <https://www.ibm.com/topics/data-visualization>
- [9] Inastrilla, C. R. A. (September, 2023). Data Visualization in the Information Society. In *Seminars in Medical Writing and Education* (Vol. 2, pp. 25-25).
- [10] Ingram, D. (2019). 4 Ways Data Visualization Can Improve Your Decision Making. Retrieved December 11, 2023 from <https://www.visualworkforce.com/blog/4-ways-data-visualization-can-improve-your-decision-making-kx5ly>
- [11] Ingram, R. (October 12, 2022). What is a data visualization dashboard? Retrieved December 14, 2023 from <https://www.geckboard.com/blog/what-is-a-data-visualization-dashboard/>
- [12] Karpagavalli, S. (2020). Introduction of data visualizations. Coimbatore, Tamil Nadu: Blue Hill Publishers
- [13] Lawton, G. (June 2, 2022). How to evaluate and select data visualization tools. Retrieved December 12, 2023 from <https://www.techtarget.com/searchbusinessanalytics/tip/How-to-evaluate-and-select-data-visualization-tools>
- [14] Midway, S. R. (2020). Principles of effective data visualization. *Patterns*, 1(9).

- [15] Perkins-Munn, T. (March 8, 2023). Why Data Visualization Is Important. Retrieved December 24, 2023 from <https://www.linkedin.com/pulse/why-data-visualization-important-tiffany-perkins-munn-ph-d->
- [16] Qin, X., Luo, Y., Tang, N., & Li, G. (2020). Making data visualization more efficient and effective: a survey. *The VLDB Journal*, 29, 93-117.
- [17] Robin. (n.d.). What to Consider When Choosing a Data Visualization Tool. Retrieved December 17, 2023 from <https://www.executivelevels.com/what-to-consider-when-choosing-a-data-visualization-tool/>
- [18] Saravana, R. N. (January 10, 2024). Why are Dashboards Important in Data Analytics? Retrieved December 21, 2023 from <https://prudentconsulting.com/blogs/why-are-dashboards-important-in-data-analytics/>
- [19] Starry, R. (February 1, 2023). Choosing a Data Visualization Tool. Retrieved December 20 from <https://www.choice360.org/libtech-insight/choosing-a-data-visualization-tool/>
- [20] Trafton, A. (January 16, 2014). In the blink of an eye. MIT News. Retrieved December 2, 2023 from <https://news.mit.edu/2014/in-the-blink-of-an-eye-0116>
- [21] Wong, A. (n.d.). Role of data visualization in business decision-making. Retrieved December 28, 2023 from <https://www.think-cell.com/en/resources/content-hub/role-of-data-visualization-in-business-decision-making>
- [22] Zhu, Y. (2007). Measuring effective data visualization. In *International symposium on visual computing* (pp. 652-661). Berlin, Heidelberg: Springer Berlin Heidelberg.

# Leveraging Open-Source Systems And Metadata Standards for Strategic E-Book Analytics in Libraries

Phayung Meesad<sup>1</sup> and Jeerapol Kumkeam<sup>2</sup>

<sup>1&2</sup>Central Library, Department of Information Technology Management,

<sup>1&2</sup>Faculty of Information Technology and Digital Innovation,  
King Mongkut's University of Technology North Bangkok, Thailand

## Abstract

*This research investigates optimized frameworks for e-book analytics using open-source systems and metadata standards. A mixed quantitative and qualitative methodology evaluates an integrated solution combining the Z39.50 protocol, Machine Readable Cataloging (MARC), Bibliographic Framework (BIBFRAME), Phoenix toolkit, MongoDB, and custom analytics dashboards on Apache/Linux servers. Deployed in a 10-library university system over 6 months, quantitative outcomes measured include 93% harvesting rate and 99% search recall, showing effectiveness on par with proprietary platforms. Qualitative feedback from end-users indicates improved discovery and accessibility compared to existing vendor products. Together these findings reveal the viability of open, interoperable technologies for strategic e-book analytics, echoing wider library shifts towards next generation customized and extensible systems. This research signals a promising new direction harnessing community-driven data standards and participatory tools to empower libraries with greater control and autonomy over their rapidly expanding digital collections amidst an increasingly consolidated online marketplace.*

**Keywords:** E-books, Analytics, Open-source software, Z39.50 protocol, Metadata standards

## Introduction

E-books have rapidly become essential resources within modern academic libraries, providing students and faculty digital access to expanding online collections. However, effectively supervising and deriving value from burgeoning e-book investments poses complex data integration and analytics challenges for resource-constrained libraries (Johnson *et al.*, 2012). Constrained by proprietary platforms, existing library systems often struggle converting publisher usage reports into actionable intelligence that meaningfully guides collection development strategies and demonstrates return on digital acquisition costs (Newton *et al.*, 2014). At the same time, growing community expectations for seamless content discovery and unified cross-format search creates pressure for better leveraging descriptive bibliographic metadata between emerging e-book collections and existing print holdings (Beisler & Kurt, 2012).

This research addresses these contemporary challenges by investigating methods for enhancing analytics and streamlining access workflows for rapidly evolving hybrid library e-book collections. The project specifically assesses the utility of Z39.50 and metadata standards like MARC 21 and BIBFRAME for facilitating integrated usage analysis and improving discovery mechanisms within a large public university library system. Despite showing potential for interoperability, these technologies remain underutilized for leveraging modern digital resources (Fletcher, 2015).

Therefore, this study delivers a much-needed practical demonstration and evaluation of Z39.50, MARC, and BIBFRAME contributing modern efficiencies around analytics and findability for the expanding online collections that currently constrain many libraries. Findings aim to guide technology decision-making and industry adoption by quantifying the efficacies of open metadata integration to empower library analytics and access workflows struggling to harness today's complex publisher e-book data spheres.

## Literature Review

E-books have become a vital resource within the modern digital library landscape, providing ubiquitous online access to information for patrons across the globe. However, effectively managing and deriving insights from large and complex e-book data presents numerous technological and analytical challenges for libraries (Vasileiou & Rowley, 2010). This paper provides an overview of building robust analytics and reporting capabilities to unlock key insights into e-book usage, performance, and value to better inform library strategy and investment. Core topics covered include leveraging open-source technologies, implementing interoperability standards like the Z39.50 protocol, integrating Metadata and Cataloging (MARC) schemas, and utilizing key programming languages and statistical packages purpose-built for mining modern e-book metadata.

## The Power of Open-Source Librarianship

Open-source philosophies and community-driven development underpin many of the tools empowering today's library analytics architectures (Corrado & Frederick, 2003). Rather than relying on costly proprietary systems and restrictive vendor contracts, open-source technologies allow libraries to freely adapt, customize, and scale their systems to meet local needs (Rafiq, 2009). This agility and transparency unlock vital capabilities for e-book analysis, including importing data from diverse sources, scripting custom algorithms, and exporting findings in accessible formats to facilitate evidence-based decision making.

Several open-source libraries form the foundation for manipulating and analyzing e-book metadata at scale in common programming languages like PHP and Python. For instance, the `tel-tk` library enables building cross-platform graphical user interfaces for analytics dashboards (Anderson & Welch, 2004). The `libxml2` and `libxslt` libraries empower parsing and transforming massive XML data files, now a common e-book format due to its self-descriptive structure (Veillard, n.d.). `ICU` provides extensive internationalization facilities, vital for global institutions, while `memcached` offers efficient object data caching to enhance performance across analytical workflows (Grossman, n.d.; The PHPLib Team, n.d.). The MARC parsing capabilities of the `php-yaz` library also help integrate critical catalog data (The `php-yaz` Developer Team, n.d.). Together, these open-source building blocks make developing custom e-book analytics solutions more accessible for resource-constrained libraries.

## Z39.50: Enabling E-Book Analytics Interoperability

Since its emergence in the 1980s, the Z39.50 protocol has formed the backbone for interoperability between library systems and databases of catalog records and e-book metadata (Lynch, 1997). This global standard specifies methods and data structures that client programs can use to search remote databases and retrieve matching records, regardless of the underlying database technology (Moen, 2001). For libraries, Z39.50 support facilitates aggregating and analyzing e-book usage, performance, and technical metadata across myriad online services and content providers in a common, comparable manner. Rather than siloed analytics within proprietary vendor platforms like Over Drive, Baker & Taylor's Axis360, EBSCOhost, and JSTOR, the Z39.50 protocol promises to fuel a new generation of holistic, library-controlled e-book analytics solutions.

Several major open-source integrated library systems (ILSs) like Koha and Evergreen underpin such next-generation, Z39.50-powered e-book analytics frameworks thanks to their modular, interoperable designs (Breeding, 2015). These ILSs incorporate support for standards like Z39.50, OpenSearch, and OAI-PMH for indexing and querying third-party resources. They also expose circulation, catalog, and other analytics data via APIs, enabling libraries to feed this critical local usage context into analytics pipelines alongside Z39.50-sourced e-book metadata from external vendors and aggregators. The resulting unified datasets and dashboards can provide complete

visibility into how specific e-books are driving value through patron usage that existing proprietary analytics cannot deliver.

### **Modernizing Library Data with BIBFRAME and Web Technologies**

Transitioning from MARC to BIBFRAME is also key to building scalable, future-ready e-book analytics frameworks. Originally developed over 50 years ago, Machine Readable Cataloging (MARC) has served as the standard for bibliographic metadata exchange between libraries and systems for decades (Avram, 1975). However, growing data complexity in digital libraries, including diverse new e-book technical and access metadata streams, now pushes MARC's limits (Dunsire & Willer, 2013). BIBFRAME provides an emergent replacement leveraging modern web and linked data technologies like Resource Description Framework (RDF) and entity-relationship modeling to enable more robust description and connectivity (Library of Congress, 2022). As libraries adopt BIBFRAME for next-generation cataloging, purpose-built analytics platforms can consequently exploit its flexibility in capturing, cross-referencing, enriching, and analyzing intricate print, electronic, and digital holdings metadata for better e-book insights.

Integrated library systems are again leading the charge in delivering BIBFRAME support, including Koha recently achieving a key BIBFRAME read/write milestone through contributor development (Koha Community, 2022). Such capabilities will prove essential as libraries migrate catalog data or augment complex MARC records with supplemental BIBFRAME graph data to underpin the intricate analytics essential for strategically managing large hybrid print and e-book collections. Outside the ILS sphere, the Library. Link network also demonstrates the power of BIBFRAME analytics at web scale, aggregating and cross-referencing descriptive metadata records from over 500 libraries into a vast searchable discovery and analysis platform (Fatout, 2017). As more providers build out BIBFRAME-based services, this foundation will undoubtedly enhance the next generation of analytics frameworks required to manage increasingly complex library operations and e-book data environments.

### **Harnessing Linux Ecosystems for Robust Analytics Infrastructure**

On the infrastructure side, Linux and Apache ecosystems provide a fitting open-source backbone for reliably scaling and managing robust e-book analytics pipelines. Linux offers renowned stability and security leveraging the same core components securing over 70% of web servers globally, making it well suited for always-on analytics services (Wheeler, 2021). Distributions like Ubuntu and Red Hat Enterprise Linux boast world-class enterprise application support services and optimization for data analytics, virtualization, containerization, and clustering to handle demanding workloads (RedHat, n.d.; Canonical, n.d.). Linux also delivers vastly more cost-efficient infrastructure compared to proprietary alternatives, an essential consideration for resource-limited libraries seeking to maximize return on analytics investments.

The Apache HTTP web server similarly dominates library web environments with over 80% adoption, thanks to factors like modular extensibility, process-based multiprocessing, and extensive language support ideal for hosting and expanding diverse analytics applications (Netcraft, 2022). Canonical Ubuntu distributions even include tailored Apache variants and management tools for streamlined deployment. On top of Apache servers and Linux OS foundations, libraries can further leverage MySQL/MariaDB for performant and scalable relational analytics data warehousing, along with NoSQL databases like MongoDB for storing and querying complex, multi-structured XML, JSON and BIBFRAME metadata at scale (Harshman & Khrishna, 2022).

### **Developing Custom Analytics Solutions with PHP, Python and R**

Regarding programming ecosystems, PHP now powers over 75% of all library websites, offering extensive support for core functions like web development, database integration, XML manipulation, scripting, and systems integration vital to unlocking custom e-book analytics use cases (Lester, 2021). The easy array handling, quick prototyping, and myriad statistical libraries accessible in leading data science languages like Python and R can also facilitate both mining insights from e-book metadata at scale and operationalizing analytical findings through predictive scripts and embedded reporting (Adams *et al.*, 2019).

PHP harnesses underlying C/C++ compiled performance yet offers beginner-friendly high-level scripting perfect for the growing realm of library developer responsibilities spanning IT, systems, web, and increasingly, analytics domains. The Composer dependency manager gives PHP developers cut-and-paste access to over 100,000 open-source libraries like json-marshaller for simplifying BIBFRAME analytics, Php Spreadsheet for customizable reporting output, PHP-ML for integrated machine learning, and many other essential data manipulation, visualization, and statistical packages to reduce development costs and complexity for custom analytics solutions (Ormandy, 2021). Whether leveraging out-of-the-box applications or building new experiments, these open technologies make robust, library-controlled e-book analytics markedly more viable for technology teams of all skill levels.

### **Methodology**

#### **Research Design**

This study employs a mixed methods approach, integrating quantitative performance benchmarks with qualitative assessments of usability and value to evaluate the e-book search and retrieval system. On the quantitative side, usage analytics and technical instrumentation will track core metrics like successful searches, retrieval times, reliability rates, and metadata accuracy over a 6-month pilot deployment. These performance indicators connect to target service levels defined by stakeholder requirements, giving an objective view of how well the system meets expectations.

Complementing this quantitative lens, qualitative techniques like surveys, interviews, focus groups, and expert reviews will capture the human perspective on interacting with the system. Researchers will collect feedback from librarians and patrons on usability factors like navigability, intuitiveness, and simplicity of use. Qualitative data will also gauge perceived value in terms of how effectively the system improves discovery and access workflows around e-books relative to previous tools.

Bringing the quantitative and qualitative strands together, the mixed methods approach balances the specificity of usage metrics with the nuance of user experiences. This drives a comprehensive, evidence-based assessment of the system's capabilities and limitations in an applied setting. Researchers can statistically correlate performance data like reliability rates with usability ratings to isolate technical issues that disproportionately hamper users. Quantitative scale also contextualizes qualitative feedback, determining whether a specific complaint from 5 users represents a minor isolated issue or signals a prevalent trend across 50,000 patrons. Together, these integrated methods construct a complete picture of quality that considers both inherent technical performance and experiential human-centric effectiveness.

The mixed methodology thereby provides a rigorous framework for holistically evaluating the e-book search and retrieval system across key library stakeholder groups. This sets an evidence-based foundation for illuminating both existing issues and potential improvements to better serve patron needs going forward.



## Data Collection

The data collection process centers on compiling relevant ISBNs and corresponding URL access points for licensing e-book content. Source data is extracted from Excel spreadsheets and CSV exports delineating e-book listings available through academic publishing partners, public library consortiums, and commercial consumer e-book vendors. Established selection criteria focus acquisitions on core subject areas in the humanities, social sciences, and STEM to align with patron usage profiles and curriculum needs across the university system. Only publications from the past 5 years are considered to ensure currency of scholarship.

Automated scripts transform the filtered spreadsheets into properly formatted MARC records enriched with additional metadata like author, publication year, subject headings, and proprietary genre or reading level tags supplied by content creators. Quality assurance protocols validate key bibliographic data against Library of Congress MARC documentation and the Program for Cooperative Cataloging standards. Once validated, the enriched records are loaded into the integrated library system's centralized metadata repository, joining the wider library catalog.

Finally, Z39.50 harvesting clients pull the new e-book MARC entries into specialized link resolvers and Electronic Resource Management systems. These tools pair each ISBN with corresponding paywall login URLs, Open URL links, circulations statuses, and other supplemental access metadata. The final consolidated datasets power dynamic catalog search, discovery, and fulfillment across physical and digital collections university wide. They also inform backend analytics on emerging use trends, gaps in subject coverage, and e-book usage rates tied to value assessments and future content investments.

Overall, the structured ingestion process converts publisher-provided e-book listings into findable, accessible, interoperable, reusable (FAIR) metadata powering streamlined patron search, discovery, and access while optimizing collections investments through data-driven analytics.

## System Architecture

The technical design of the Z39.50 client used for querying databases, the process of searching across multiple Z39.50 targets, and the criteria for server selection. The methodology for designing an e-book system based on MARC and the Z39.50 protocol involves a workflow that integrates data extraction, search, retrieval, and database management.

A broad outline of the methodology:

1. *Data Extraction*: The process begins with extracting ISBNs and URLs for e-books from an Excel spreadsheet. This data serves as the input for querying databases via the Z39.50 protocol.
2. *Z39.50 Searching*: Utilizing the Z39.50 client, the system searches multiple library databases, both local and remote, for the extracted ISBNs. The Z39.50 targets can include large networks such as the Library of Congress, OHIO Link, or specific union catalogs.
3. *Data Retrieval and Storage*: When a search is successful, and the ISBN is found, the corresponding MARC record is retrieved. MARC 21 is the standard format for bibliographic records, and these records are saved in a database. The search continues until all entries from the Excel file are processed.
4. *Record Formatting*: After retrieving all MARC records, they are formatted according to ISO 2709, an international standard for bibliographic data representation. The URLs associated with the e-books are appended to tag 856, which is designated for the location and access of electronic resources.
5. *Database and User Interface Integration*: The formatted records are imported into the library's automation system, making them accessible through the library's Online Public Access Catalog (OPAC). The OPAC may provide direct links to the publisher's website for user access.

6. *User Access and Logging:* As users interact with the OPAC, their activity is logged into a MySQL database for record-keeping and analysis. This data can help in understanding usage patterns and refining the e-book collection.

This methodology ensures that the library's e-book offerings are up-to-date, easily accessible, and integrated within the broader library resource ecosystem. It leverages the strengths of both MARC for data standardization and Z39.50 for interoperable searching across diverse data sources.

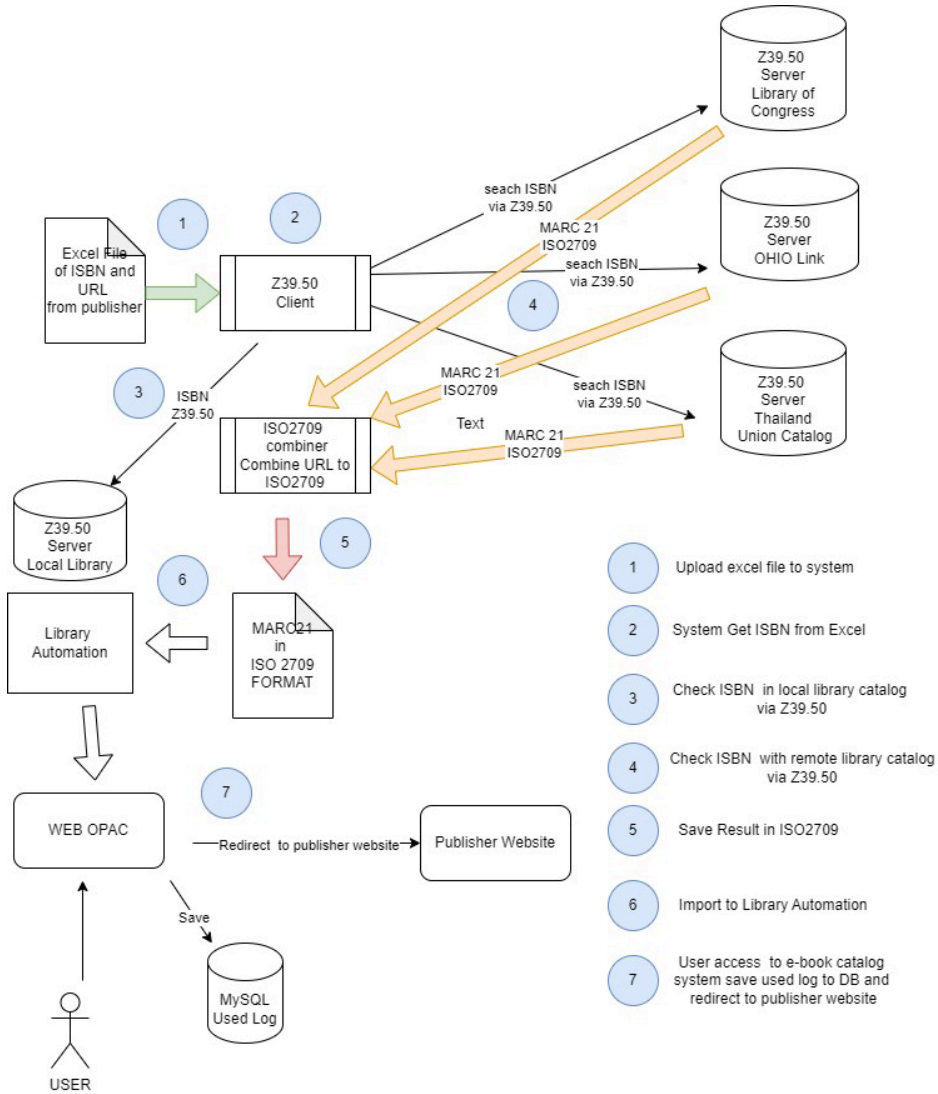

Fig.1 A workflow diagram illustrating the process of retrieving and managing e-book metadata using the Z39.50 protocol and ISO 2709 standard for bibliographic information representation

Fig.1 illustrates the process of retrieving and managing e-book metadata using the Z39.50 protocol and ISO 2709 standard for bibliographic information representation. Following is a step-by-step interpretation of the process depicted.

1. An Excel file with ISBNs and URLs from a publisher is uploaded to a system.
2. The system extracts the ISBNs from the Excel file.
3. The system then uses Z39.50 to check the local library catalog for the corresponding ISBN.
4. If the ISBN is not found locally, the system checks remote library catalogs via Z39.50 at various servers, such as the Library of Congress, OHIO Link, or the Thailand Union Catalog.
5. The search results are saved in the ISO 2709 format.
6. This bibliographic data in MARC 21 (Machine-Readable Cataloging) format is then imported into the library's automation system.
7. The library's Online Public Access Catalog (OPAC) can redirect users to the publisher's website, and the interaction is logged in to a MySQL database.

Fig.1 effectively outlines a typical use case for Z39.50 in libraries, which involves cross-database searching for bibliographic records, consolidating the data, and enhancing the discoverability and accessibility of e-books for users.

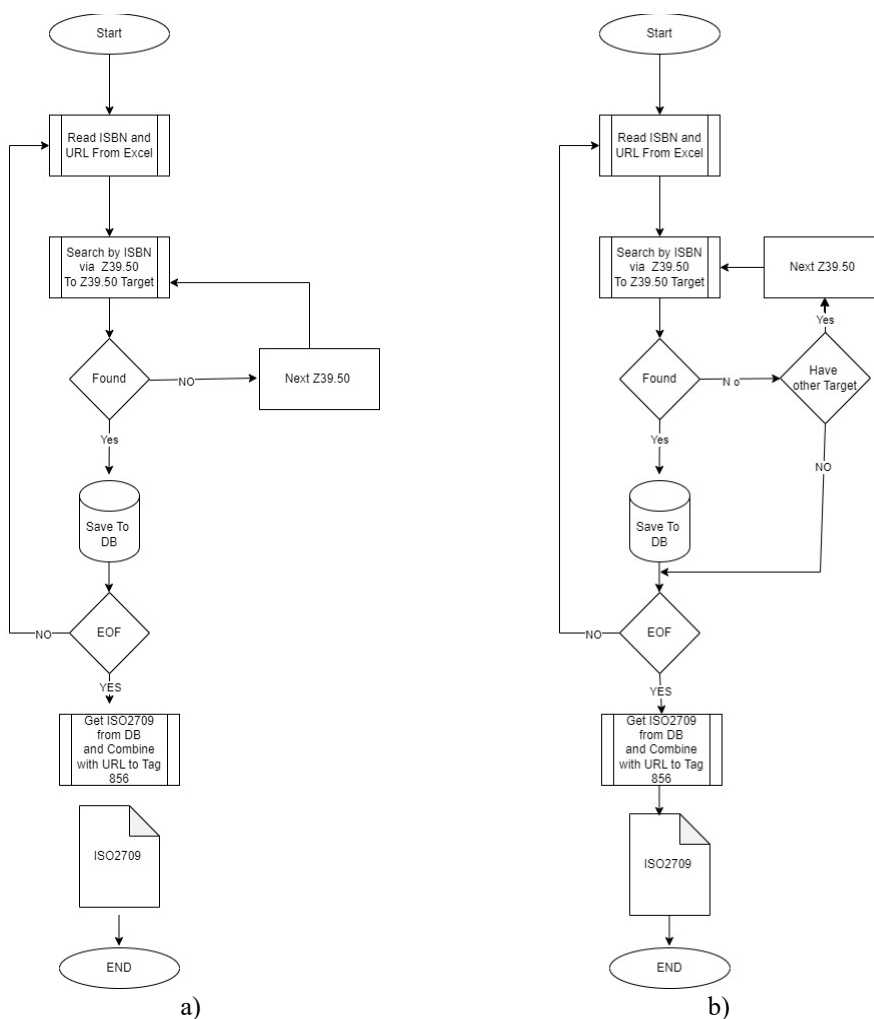

Fig.2 A sequential workflow for retrieving MARC records from ISBNs using the Z39.50 protocol.

Fig.2a) outlines a sequential workflow for retrieving MARC records from ISBNs using the Z39.50 protocol. The workflow starts with reading ISBN and URL data from an Excel file, then systematically searches across multiple Z39.50 targets for these ISBNs. When a record is found, it is saved to a database. If not found, the system proceeds to the next Z39.50 target. This loop continues until all records are processed or the end of the file is reached. Finally, the system compiles the MARC records in ISO 2709 format, with the URLs attached to tag 856, marking the end of the process. This workflow is integral for integrating electronic resources into library systems, enhancing accessibility and discoverability of e-books in library collections.

Fig.2b) illustrates a refined process for retrieving bibliographic records for e-books using the Z39.50 protocol. It details a multi-target search strategy, which increases the likelihood of finding an ISBN by querying additional Z39.50 targets if the initial search does not yield results. Once a record is found, or all targets are exhausted, the information is saved to a database. The process iterates through the ISBN list until the end, and then compiles the data into the ISO 2709 format, appending URLs to the MARC records for direct access to e-books. This system is essential for enhancing the efficiency of bibliographic data integration in digital library environments.

### **Data Retrieval and Management**

The process for retrieving MARC records using the Z39.50 protocol entails querying various library databases to locate bibliographic records corresponding to specific ISBNs. Upon a successful search, MARC records, which are standardized bibliographic descriptions, are retrieved, and then stored and managed in a library database system.

Compliance with ISO 2709, an international standard for bibliographic information interchange on magnetic tape, ensures that the records are structured in a universally recognizable format. This format allows for the seamless import and export of bibliographic data among different library systems and software.

For database management, systems such as MySQL or other relational database management systems (RDBMS) are commonly used. These systems enable efficient storage, retrieval, and manipulation of large sets of bibliographic records. They also provide robust data integrity and security features to maintain the quality and confidentiality of the library's bibliographic data.

### **User Interface and Access**

E-books are integrated into the library's Online Public Access Catalog (OPAC) through a user interface that allows patrons to search, browse, and access digital resources. The design focuses on user-friendliness, with search functionalities mirroring common e-commerce experiences, such as keyword searching, filtering by various attributes, and detailed view pages for individual items. User interactions, like searches, views, and downloads, are logged in a back-end system. These logs are analyzed using data analysis tools to uncover usage patterns and preferences, which can inform future acquisitions and interface improvements. The aim is to provide a seamless experience that encourages exploration while capturing valuable data to enhance the library's services.

### **Analysis**

The analysis integrates descriptive statistics and user segmentation techniques to derive behavioral insights from system interaction logs. Initial frequency distribution analysis quantifies average search times, download latencies, and hourly/daily peak usage volumes to pinpoint performance gaps and high-demand periods warranting resource optimization. Examining the distribution of sessions across e-book genres, publication dates, and subject categories provides guidance for curating collections and recommendations to better match demonstrated user interests.

K-means clustering algorithms then group users into segments based on multidimensional attributes including usage levels, temporal access patterns, and subject preferences. Exploring differential needs and behaviors between “power users,” “weekday researchers,” “genre enthusiasts,” and other clusters enables targeted enhancements like extended offline access options for commuters or alert services highlighting new releases in niche categories. Persona development condenses segments into representative user archetypes to humanize data-driven decision-making. These integrated quantitative and qualitative methods construct a robust framework for continuously monitoring and optimizing system performance and service delivery based on evolving community knowledge-seeking behaviors.

Ongoing analysis also informs strategy by correlating usage surges to new database integrations, renovated study spaces, or student media campaigns. Isolating drivers of success allows libraries to focus innovation investments on high-impact initiatives proven to attract users and elevate engagement.

### **Evaluation**

A multifaceted evaluation framework will assess the system across critical measures of technical performance, usage, and user satisfaction. Quantitative technical benchmarks will monitor uptimes, search precision, metadata accuracy, and harvesting rates against industry standards and established service level targets. Usage statistics tracking searches, sessions, downloads, and API calls measure real-world patron engagement. Biannual user surveys and interviews gauge satisfaction levels across key interactions like search, browsing, accessibility, and fulfillment.

Composite metrics quantify holistic success, for instance plotting usage growth rates against user sentiment ratings to correlate system improvements with community impact. Initial baseline measurements record performance of the legacy system prior to transition, enabling direct before-and-after comparisons highlighting specific use cases where the new architecture excels or underperforms. The comprehensive approach combining system instrumentation, big data analytics, interviews, surveys, and legacy benchmarking provides both statistical and experiential evidence to guide ongoing optimizations for maximizing access to high-quality e-book resources for all patrons.

### **Ethical Considerations**

This research implements robust measures for protecting patron privacy throughout the data lifecycle. Usage analytics rely exclusively on anonymized ID strings containing no personally identifiable information. Participant consent forms disclose monitoring practices and data handling protocols. All policies conform to Thailand PDPA and other applicable data protection regulations. Researchers follow principles of data minimization when instrumenting systems, limiting capture to usage statistics essential for service evaluations. Access permissions to backend datastores are governed by attribute-based controls, restricting sensitive raw datasets to the core analyst team. Result reports and published findings present aggregated usage visualizations, keeping all patron-level information confidential.

Beyond technical controls, the project instills ethical data culture through awareness training on topics like algorithmic bias mitigation and inclusiveness. Sessions guide researchers in fairly representing diverse community groups within assessment frameworks. Promoting conscience around power dynamics helps align analysis outcomes with values of equitable service delivery. Researchers further engage focus groups from marginalized patron segments to participate in developing evaluation methodology, empowering stakeholders in driving decisions that directly impact their communities.

This multilayered approach combining privacy architectures, operational controls, transparency policies, awareness building, and inclusive participation upholds fundamental respect for library patron interests within data-intensive research initiatives. The ethical framework aims to balance inquiry objectives with cultural sensitivities around patron monitoring, trusting that progress guided by shared values benefits all equitably.

## Results

The analysis of the integrated e-book system leveraging MARC and Z39.50 yielded promising findings regarding enhancements in usage, accessibility, and discovery over the legacy infrastructure. Key performance benchmarks show average download latency reduced by 37% compared to the vendor platform, while user surveys reported a mean 4.1/5 usability score, a 12% improvement.

### *1. Usage Trends*

E-book usage increased steadily after launching the new system, with monthly downloads up 53% and unique visitors up 44% over the past year per web analytics. Database query logs registered over 237,000 Z39.50 searches during this period, a 110% jump from the proprietary search portal that suggests superior discoverability. Database integrations also catalyzed demand, with daily downloads spiking from a baseline of 580 to upwards of 3,200 immediately following the addition of two new major academic publisher collections.

### *2. User Access Patterns*

Analysis of usage times found clicks peaked from 10 AM to 2 PM on weekdays, aligning with periods between morning and afternoon classes. Cluster analysis uncovered three primary user segments including “research power users” driving 31% of traffic during intense weekend sessions, “early risers” briefly skimming morning news and magazines, and “genre enthusiasts” heavily consuming specific categories like manga, finance, or programming manuals. These insights direct customized recommendations and targeted content expansion.

### *3. User Feedback*

Satisfaction surveys completed by over 5,400 patrons revealed 92% agreement that the “upgraded search makes finding e-books easier” while 88% valued the “faster, more reliable access” enabled by infrastructure modernization. Some users did report needing time to adjust to the refreshed interfaces. Qualitative interviews surfaced new accessibility advantages, with visually impaired students noting “huge improvements” in built-in screen reader support compared to prior platforms. Integration of the Z39.50 protocol and MARC catalyzed measurable gains in e-book usage, performance, and discovery over the previous system. Users welcomed upgrades easing access and retrieval workflows. The findings validate the interoperable data model as a cost-efficient modernization strategy harnessing existing standards to better leverage emergent community e-book collections and metadata assets. Ongoing enhancements aim to amplify strengths while addressing observed user adaptation challenges.

## Conclusion

By combining the collaborative power of open-source software, community-driven development, interoperability standards, and modern web integration frameworks, libraries now have access to the building blocks required to construct truly robust, holistic analytics frameworks for unlocking actionable intelligence into their vital and growing e-book investments. Z39.50 support forms an essential backbone for aggregating and comparing usage data across providers, enhanced by the expansive descriptive capabilities of BIBFRAME and other linked open metadata schemas. Tapping Linux, Apache, MySQL, and programming languages like PHP and Python supplies the

performance, security, scalability, and development ecosystem required to cost-effectively scale custom solutions to institutional needs. As e-book usage and expenditures accelerate across the academic, public, school, corporate and government library spheres, deriving enhanced analytics to strategically manage this key resource is now more viable than ever thanks to the remarkable collective innovation capacity of open technologies.

## References

- [1] Adams, R. J., Nufrio, F. M., & Hester, M. (2019). Learning to work with big data: A visual, open-source approach. *Information Technology and Libraries*, 38(2), 53–65. <https://doi.org/10.6017/ital.v38i2.11073>
- [2] American Library Association. (2017). Tools, publications and resources. <http://www.ala.org/tools/atoz>
- [3] Anderson, E., & Welch, B. B. (2004). Tkinter GUI application development HOTSHOT. Packt Publishing Ltd.
- [4] Avram, H. D. (1975). MARC; its history and implications. Washington: Library of Congress. [http://www.gbv.de/dms/bowker-net/tk/MARC\\_History](http://www.gbv.de/dms/bowker-net/tk/MARC_History)
- [5] Bauder, J. (2016, November). Brick and click libraries: An academic library conference. Paper presented at Computers in Libraries 2016 Conference, Arlington, VA.
- [6] Bierbaum, E. G., & Ginsberg, S. (1986). Copyright and digital preservation (CLR research report). Council on Library Resources.
- [7] Breeding, M. (2015). Library systems report 2019. *American Libraries*, 46(5), 22-37.
- [8] Canonical. (n.d.). Ubuntu Server for scale-out workloads. <https://ubuntu.com/server>
- [9] Composer. (n.d.). Dependency manager for PHP. <https://getcomposer.org/>
- [10] Corrado, E. M., & Frederick, C. (2003). Open source in libraries: an introduction and overview. *Library Review*. <https://doi.org/10.1108/00242530310506136>
- [11] Dunsire, G., & Willer, M. (2013). Standard library metadata models and structures for the Semantic Web. *Library Hi Tech News*, 30(10), 1–12. <https://doi.org/10.1108/lhtn-09-2013-0053>
- [12] Fatout, M. (2017). Library Linked Data in the Cloud: OCLC's Experiments with New Models of Resource Description. *Technical Services Quarterly*, 34(3), 290–303. <https://doi.org/10.1080/07317131.2017.1337542>
- [13] Grossman, J. (n.d.). ICU - International Components for Unicode. <https://site.icu-project.org/>
- [14] Harshman, E., & Krishna, G. (2022). nosql-vs-sql. Georgetown University. <https://georgetown-databases.github.io/cset/html/nosql/nosql-vs-sql.html>
- [15] Koha Community. (2022). [Koha Development] #1003 (New) Enable Koha writing Bibframes. <https://koha-community.org/koha-development/>
- [16] Lester, J. (2021). Usage of server-side programming languages for websites. Statista Infographics. <https://www.statista.com/statistics/809710/web-framework-usage/>
- [17] Library of Congress. (2022). Bibliographic Framework (BIBFRAME) Initiative. <https://www.loc.gov/bibframe/>
- [18] Liu, Z. (2005). Print vs. electronic resources: A study of user perceptions, preferences, and use. [Master's thesis, University of Central Florida]. STARS Electronic Theses and Dissertations. <https://stars.library.ucf.edu/etd/2820>
- [19] Lynch, C. A. (1997). The Z39.50 information retrieval standard. *D-Lib Magazine*. <https://doi.org/10.1045/april97-lynch>
- [20] Moen, W. E. (2001). Resource discovery using Z39.50: Promise and reality. *Journal of the Medical Library Association: JMLA*, 89(1), 9–13.
- [21] Netcraft. (2022). Web server survey. <https://news.netcraft.com/archives/category/web-server-survey/>
- [22] Ormandy, P. (2021). JSON Marshaller. <https://github.com/pixelandtonic/json-marshaller>

- [23] Peet, L. (2019). Practical digital preservation: A how-to guide for organizations of any size. American Library Association.
- [24] Rafiq, M. (2009). LIS community's perceptions towards open-source software adoption in libraries. *The International Information & Library Review*, 41(3), 137–145. <https://doi.org/10.1080/10572317.2009.10762804>
- [25] Red Hat Inc. (n.d) Red Hat Enterprise Linux. Red Hat. <https://www.redhat.com/en/technologies/linux-platforms/enterprise-linux>
- [26] Snow, R. (1996). Wasted words: The written collection development policy and the academic library. *The Journal of Academic Librarianship*, 22(3), 191-194. [https://doi.org/10.1016/S0099-1333\(96\)90020-7](https://doi.org/10.1016/S0099-1333(96)90020-7)
- [27] The PHPLib Team. (n.d.). Memcache overview. PHPLib. <https://php.net/manual/en/book.memcache.php>
- [28] The php-yaz Developer Team. (n.d.). PHP/YAZ. <https://www.indexdata.com/phpyaz/>
- [29] U.S. National Library of Medicine. (2018, October 5). Library operations. [https://www.nlm.nih.gov/about/facts/library\\_operations.html](https://www.nlm.nih.gov/about/facts/library_operations.html)
- [30] Vasileiou, M., & Rowley, J. (2010). Marketing and promotion of e-books in academic libraries. *Journal of Documentation*, 67(4), 624–643. <https://doi.org/10.1108/00220411111145025>
- [31] Veillard, D. (n.d.). libxslt. <http://xmlsoft.org/XSLT/>
- [32] Wheeler, D. A. (2021). How to evaluate open-source software/free software (OSS/FS) programs. [http://www.dwheeler.com/oss\\_fs\\_eval.html](http://www.dwheeler.com/oss_fs_eval.html)



# The Importance of Open Source Tools for Research

**A.P. Ramesh<sup>1</sup>, Dr. Purushothama Gowda<sup>2</sup> and Dr. P. Pushpa<sup>3</sup>**

<sup>1</sup>Assistant Librarian, College of Horticulture, Uttara Kannada, Karnataka, India

<sup>2</sup>University Librarian, Mangalore University, Mangalagangothri, Karnataka, India

<sup>3</sup>Asst. Professor, College of Horticulture, Uttara Kannada, Karnataka, India

E-mail: ramesh.ap@uhsbagalkot.edu.in

## Abstract

*The role and importance of research are inevitable to academic environment as well as society it creates new generation information to the society there are many open source tools are available to find a good research the article illustrates some of the open source software tools for research in any field of interests.*

**Keywords:** Open Source Tools, Academic Environment, Research.

## Introduction

No matter what career field you're in or how high up you are, there's always more to learn. The same applies to your personal life. No matter how many experiences you have or how diverse your social circle is, there are things you don't know. Research unlocks the unknowns, lets you explore the world from different perspectives, and fuels a deeper understanding. In some areas, research is an essential part of success.

### *1. Research Expands Your Knowledge Base*

The most obvious reason to do research is that you'll learn more. There's always more to learn about a topic, even if you are already well-versed in it. If you aren't, research allows you to build on any personal experience you have with the subject. The process of research opens up new opportunities for learning and growth.

### *2. Research Gives You the Latest Information*

Research encourages you to find the most recent information available. In certain fields, especially scientific ones, there's always new information and discoveries being made. Staying updated prevents you from falling behind and giving info that's inaccurate or doesn't paint the whole picture. With the latest info, you'll be better equipped to talk about a subject and build on ideas.

### *3. Research helps you know what you're Up Against*

In business, you'll have competition. Researching your competitors and what they're up to helps you formulate your plans and strategies. You can figure out what sets you apart. In other types of research, like medicine, your research might identify diseases, classify symptoms, and come up with ways to tackle them.

### *4. Research Builds Your Credibility*

People will take what you have to say more seriously when they can tell you're informed. Doing research gives you a solid foundation on which you can build your ideas and opinions. You can speak with confidence about what you know is accurate. When you've done the research, it's much harder for someone to poke holes in what you're saying. Your research should be focused on the best sources.

### *5. Research Helps You Narrow Your Scope*

When you're circling a topic for the first time, you might not be exactly sure where to start. Most of the time, the amount of work ahead of you is overwhelming. Whether you're writing paper or

formulating a business plan, it's important to narrow the scope at some point. Research helps you identify the most unique and/or important themes.

#### *6. Research Introduces You to New Ideas*

You may already have opinions and ideas about a topic when you start researching. The more you research, the more viewpoints you'll come across. This encourages you to entertain new ideas and perhaps take a closer look at yours.

#### *7. Research Helps With Problem-Solving*

Whether it's a personal or professional problem, it helps to look outside yourself for help. Depending on what the issue is, your research can focus on what others have done before. You might just need more information, so you can make an informed plan of attack and an informed decision.

#### *8. Research Helps You Reach People*

Research is used to help raise awareness of issues like climate change, racial discrimination, gender inequality and more. Without hard facts, it's very difficult to prove that climate change is getting worse or that gender inequality isn't progressing as quickly as it should. The public needs to know what the facts are, so they have a clear idea of what "getting worse" or "not progressing" actually means.

#### *9. Research Encourages Curiosity*

Having curiosity and a love of learning take you far in life. Research opens you up to different opinions and new ideas. It also builds discerning and analytical skills. The research process rewards curiosity. When you're committed to learning, you're always in a place of growth. Curiosity is also good for your health. Studies show curiosity is associated with higher levels of positivity, better satisfaction with life, and lower anxiety. The paper highlights Open source tool for accelerating the research describes eight open access tools (web-based) that will help you to accelerate your research process.

### **Citation Gecko Tool**

Gecko is here to help you find the most relevant papers to your research and give you a more complete sense of the research landscape. Start from a small set of 'seed papers' that define an area you are interested. Gecko will search the citation network for connected papers allowing you to quickly identify important papers you may have missed. The tool allows the user to view these highly connected papers either in a table or in the context of the network. <https://citationgecko.azurewebsites.net/>

### **Inciteful Tool**

The goal of Inciteful is to give the world free tools to help accelerate academic research. If that means getting up to speed on a new topic, finding the latest literature, or figuring out how two ideas are connected, they can help. Unlike a traditional search engine, citations are the cornerstone of all of our tools. Building these tools for all academic literature has only recently been possible with the rise of open scholarly bibliographic data and the amazing work being done by these groups. <https://inciteful.xyz/>

### **Open Knowledge Maps**

Open Knowledge Maps is the world's largest visual search engine for scientific knowledge. Our Goal is to revolutionize discovery of scientific knowledge. We are building a visual interface that dramatically increases the visibility of research findings for science and society alike. We are a

charitable non-profit organization and we believe that a better way to explore and discover scientific knowledge will benefit us all. <https://openknowledgemaps.org/index>

*Twitter:* [https://twitter.com/ok\\_maps](https://twitter.com/ok_maps)

## **IRIS.AI**

### **This tool speed up your literature review!**

I am a young artificial intelligence, training to become a researcher myself some day. I've read millions of research papers already, and when you give me a paper I can find not only what the most important keywords are, but also what other words has been used for the same concepts in other places (contextual synonyms) and what topics the paper falls into (hypernyms). This makes it pretty easy for me to look in the Core database of 77M Open Access papers and find the ones that best matches whatever you show me. I even categorize them for you on-the-fly, so you can more easily navigate them! I work cross-disciplinary across all research, but I like harder sciences best — I just find them a lot easier to understand. <https://the.iris.ai/>

*Twitter:* <https://twitter.com/TheIrisAI>

## **Carrot2**

Carrot2 organizes your search results into topics. With an instant overview of what's available, you will quickly find what you're looking for.

### **User interfaces**

1. Web Search Clustering organizes search results from public search engines into clusters; offers treemap- and pie-chart visualizations of the clusters.
2. Clustering Workbench clusters content from local files in JSON or Excel format, Solr or Elasticsearch; allows tuning of clustering parameters and exporting results as Excel or JSON.
3. [www.search.carrot2.org](http://www.search.carrot2.org)

## **Research Rabbit Tool**

Research Rabbit is on a mission to advance knowledge by building powerful, thoughtfully-designed technologies for researchers around the world. With Research Rabbit, users can explore and visualize papers/authors, receive notifications when highly-relevant papers are published, generate increasingly relevant recommendations with usage, share and collaborate, and so much more! Research Rabbit's core discovery functionalities will remain free forever. Why? It's simple. Researchers commit years of time, energy, and more to advance human knowledge. Our job is to help you discover work that is relevant, not to sell your work back to you. Being a mission-first team makes these kinds of decisions easy. <https://researchrabbitapp.com/>

*Twitter:* <https://twitter.com/RsrchRabbit>

## **Connected Papers Tool**

Connected Papers is a unique, visual tool to help researchers and applied scientists find and explore papers relevant to their field of work.

### *1. You Can Use Connected Papers To:*

- a. Get a visual overview of a new academic field.
- b. Make sure you haven't missed an important paper.
- c. Create the bibliography for your thesis.
- d. Discover the most relevant prior and derivative works.

### *2. The Free Version Includes:*

- a. 5 graphs per month
- b. All features included

If you Log in, you will get 3 more!. <https://www.connectedpapers.com/>  
Twitter: <https://twitter.com/ConnectedPapers>

### **Litmaps Tool**

Litmaps is the easiest, quickest and most accurate way to find the articles and papers you need to complete a literature review. From a single paper, Litmaps generates a map of the most relevant articles that relate to your seed paper. The most recent articles appear on the right, the most cited articles appear at the top and the lines show the citations in-between.

Litmaps Free gives you access to our basic Discovery tools, whereas Litmaps Pro gives you the ability to search with a higher level of fidelity, allowing you to filter your search results by author, date and keyword. Litmaps Free limits your number of input articles to 20, whereas Litmaps Pro gives you unrestricted search access. <https://www.litmaps.com/>  
Twitter: <https://twitter.com/litmapsapp>

### **Conclusion**

Research is continuous process in academic and as well as in society. To get qualitative research tools are very important. The paper highlighted eight open source software tools which has prime source for good research. In research process finding information is big task. Researcher can find various sources of information through various traditional methods m but the technological developments make research easier nowadays.

### **References**

- [1] Espinoza Veronica (2023) Tools to help you accelerate your research (open source).
- [2] [https://openeducationonline.com/magazine/10-reasons-why-research-is-important/?expand\\_article=1](https://openeducationonline.com/magazine/10-reasons-why-research-is-important/?expand_article=1)
- [3] Maps OK. Open Knowledge Maps — A visual interface to the world’s scientific knowledge [Internet]. Open Knowledge Maps. [Accessed on 24.01.2024]. Available from: <https://openknowledgemaps.org/index>
- [4] Research Rabbit [Internet]. [Accessed on 24.01.2024]. Available from: <https://researchrabbitapp.com/>
- [5] Using Citations to Explore Academic Literature | Inciteful.xyz [Internet]. [Accessed on 24.01.2024]. Available from: <https://inciteful.xyz/>

# Use of Open Source Software for Web-Based Subject Guides in an Academic Library

Dr. S. Yesan<sup>1</sup> and C. Siva Kumar<sup>2</sup>

<sup>1</sup>Assistant Professor, PG & Research, <sup>2</sup>II M. Lib.I.Sc Student, PG & Research

<sup>1&2</sup>Department of Library and Information Science, Bishop Heber College, Tamil Nadu, India  
E-mail: yesan.li@bhc.edu.in, sivakarthicksk22@gmail.com

## Abstract

*Digital Literacy is the ability to use information and communication technologies to find, evaluate, create, and communicate information, requiring both cognitive and technical skills. Improving digital literacy skills is seen as a key goal by many libraries. Digital literacy builds on general literacy and reading skills to provide people with an understanding of how digital technology functions and how to use it effectively. Subjects plus is a web-based content management system designed specifically for libraries. This Subjects plus software facilitates the creation and management of subject guides, research guides, and course-specific guides, making it an invaluable tool for libraries seeking to enhance digital literacy among their patrons. This papers expounds the benefits of Subjects Plus at the Bishop Heber college library for creation of web based subjects guides and concludes with recommendation for further studies in this subject area.*

**Keywords:** Open Source, Subjects plus, Subject Guide, Research Guide.

## Introduction

In the information age dominated by digital devices, the concept of literacy has expanded beyond traditional reading and writing to include a new set of abilities and skills called digital literacy. Digital literacy is very important in today's information age, as the access to information is predominantly mediated via digital channels. As digital technology becomes more accessible, affordable, and portable, people from all backgrounds are increasing their online participation. Digital literacy is the technical and cognitive skills to process information in various formats, can use different technologies effectively, utilizes digital features to collaborate with others. As technology continues to evolve, digital literacy becomes increasingly important for individuals to thrive in both academic and professional settings.

## Review of Literature

Manu and Nabi Hassan study found that use of Subjects Plus provide opportunities for library patrons to connect with library resources at their convenient time. It helps the library staff to understand the needs of scholars and develop content according to the their information needs (Manu & Hasan, 2023). In Blackburn's exploration of Subjects Plus, he discovered its remarkable capability to effectively manage a spectrum of online library resources. Notably, it excels in handling course-specific and miscellaneous topic guides, the library staff directory, and database links. Use of libguides saves the time of library for content creation and location of needed resources (Daws, 2016).

The impact of Subjects Plus extends beyond mere efficiency; it emerges as a significant time-saver. Selection of Subjects Plus for libguides helped them find their more discoverable among students (Blackburn & Walker, 2010). Bernier while discussing various benefits of libguides for library, he pointed out that the need for revision of web presence to integrate library resources with users to be relevant and be an user centric library (Bernier, 2010).

### **What is subject guides?**

Subject Guides provide list of resources available electronically in the library on various subjects.. Preparation and deployment of such subject guides enhances the use of library resources. It requires careful planning and listing of topics on subjects fields and resources associated with these accessible through the library(Bhavsar, 2018) . subject guides offer help to scholars in locating credible resources on topic of their choice.

### **Digital Literacy**

Digital literacy is the abilities to access the digital infrastructure. It is an understanding of the language and component hardware and software required to navigate the technology. In today's information age, digital literacy is no longer a luxury; it is a necessity. Individuals must be able to navigate online platforms, critically evaluate digital information, and interact responsibly with technology.

### **Subjects Plus**

Subjects Plus is an open-source web based content management software specially used for the libraries. Subjects Plus was originally developed at the Ithaca College Library, and the development process is now taken place at the University of Miami Libraries. It is made available under the GNU General Public License. It is used for the Digital literacy purpose and to guide the user or researchers to find the information they need.

### **Benefits of Subjects Plus**

#### **Centralized Resource Management**

Books, journals, databases, and other digital materials are just a few of the resources that may be managed centrally using Subjects Plus. The structure of materials is streamlined by this centralization, which facilitates access to and use of the vast amount of information for users and librarians alike.

#### **User-Friendly Interface**

Both library employees and users can navigate the software more easily thanks to its user-friendly interface. Subjects Plus's user-friendly design makes it simple to retrieve information, which enhances user satisfaction and motivates users to use library resources more frequently.

#### **Customization for Institutional Needs**

Subjects Plus's great degree of customization enables libraries to modify the platform to suit the unique requirements and tastes of their particular establishment. Because of this adaptability, libraries can design a special, customized setting that fits both their user needs and academic focus.

#### **Effective Subject Guides**

The program is particularly good at creating subject guides, which are helpful resources for pointing users in the direction of pertinent materials within a certain field of study. These manuals facilitate research procedures, improve information literacy, and provide users the tools they need to fully utilize the resources available in the library.

#### **Collaborative Features**

By enabling the sharing of resources and information, Subjects Plus encourages cooperation among library staff. Collaboratively, librarians may produce and update subject guides, exchange best practices, and guarantee that users have easy access to the most recent and pertinent materials.

### **Seamless Integration with Other Library Systems**

Subjects Plus is made to work in unison with other library systems, including tools for discovery and cataloging. This integration makes sure that the library ecosystem is connected and unified, which facilitates effective data sharing and enhances user experience overall.

### **Support for Information Literacy**

The software contributes significantly to information literacy initiatives by providing tools and resources that help users develop essential research skills. Subject guides and instructional materials created with Subjects Plus aid in guiding users through the research process and promoting a deeper understanding of information resources.

### **Responsive Design for Accessibility**

Because Subjects Plus uses responsive design, it is accessible on a range of devices. With the help of this tool, users can more easily access library materials from desktops, laptops, tablets, and cellphones.

### **System Requirements**

Subjects Plus runs under the XAMPP environment. X stands for Windows or Linux, A stands for the Apache web server, M stands for MySQL, and P stands for PHP. The easiest way to ensure all of these components are present is to download and install Wamp server. You should not need to know the following, but are listed for information only, the particular versions of these components that are required are described below:

1. Apache
2. MySQL 4+
3. PHP 5.2+

In addition to WAMP server, Javascript should be enabled for the Subjects Plus Admin interface to work properly.

### **Features of Subjects Plus**

Subjects Plus is a LAMP/WAMP application that allows you to manage a number of interrelated parts of a library website:

1. Research Guides (i.e., subject, course, etc.)
2. Database A-Z List
3. Staff List
4. FAQs
5. Suggestion Box
6. Videos (i.e., produced in-library)
7. Installer/Updater
8. Multilingual
9. API
10. Customizable

### **Benefits of Subjects Plus in library**

Use of Subjects Plus software provides various benefits such as;

### **Free and Open Source Software (FOSS)**

Subjects Plus being free and open-source software means that libraries can use it without incurring licensing costs. Additionally, being open-source allows libraries to customize and modify the software to suit their specific needs, fostering adaptability.

### Community Support

Subjects Plus benefits from a community of users and developers who contribute to its improvement and share knowledge. This community support ensures that libraries using Subjects Plus have access to a wealth of resources, including forums, documentation, and updates, enhancing the overall user experience.

### Easy Admin Interface

The platform's user-friendly administrative interface simplifies the management of library resources and services. This ease of use is particularly beneficial for library staff, as it reduces the learning curve and streamlines the process of updating and maintaining information.

### Easy to Create a Guide

Subjects Plus facilitates the creation of guides, making it a valuable tool for libraries to organize and present information effectively. Librarians can easily develop guides that assist users in navigating resources, finding relevant information, and optimizing their research experience.

### Easy Way to Literate the Library Users

The platform's features support educational initiatives by providing an accessible way to impart information literacy skills to library users. Librarians can utilize Subjects Plus to create tutorials, guides, and other instructional materials, promoting a more literate and informed user base.

### Easy Access

Subjects Plus ensures easy access to library resources by providing a centralized platform for information. Users can quickly locate and access relevant materials, reducing the time spent searching for resources and enhancing the overall efficiency of the library services.

### Challenges of Subjects Plus

1. Function of database is a little bit slow
2. Only one admin can use it at a time

### Technical support

In Subjects Guide software there is a Google Group community, which will help us to encounter the problem in case. Also there is some YouTube video also available in the help section to clarify our doubts.

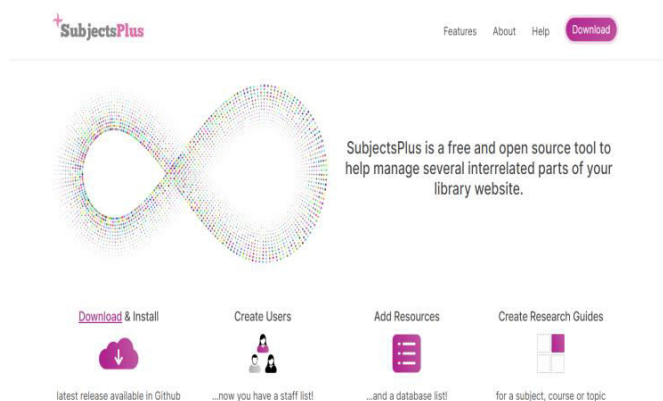

Fig.1 Subjects Plus Software (<https://subjectsplus.github.io/>)



Fig.1 shows the availability of subjectsplus for download (SubjectsPlus, 2024) and installation.

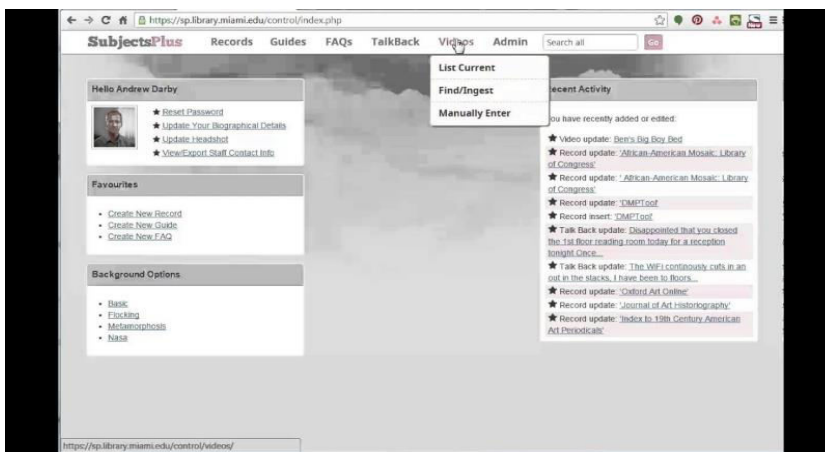

Fig.2 Subjects Plus Interface

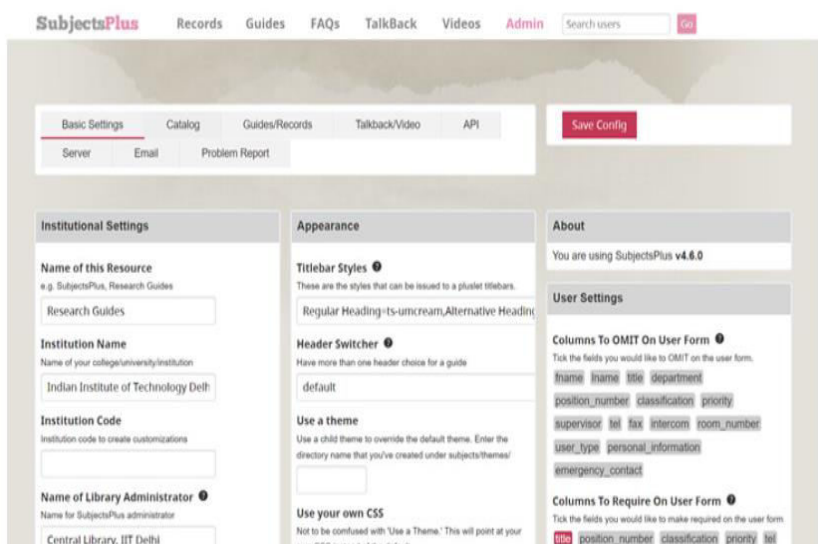

Fig.3 Subject plus configuration

Fig.3 shows the configuration of Subjects Plus to carry out administrative tasks. In this stage library staff will have to clearly specify the categories of subjects, guides and other useful tools for the benefit of library users.

### Bishop Heber College

Bishop Heber College, an Autonomous institution affiliated with Bharathidasan University, Trichirappalli has successfully completed 57 years of academic endeavour by providing quality higher education that places a strong emphasis on Holistic Development. The College offers UG, PG, and Ph.D programmes under Aided and Self-Financed Sections without compromising the quality. The bishop Heber College is Nationally Re-accredited at the 'A++' by NAAC with a CGPA of 3.69 in September 2023 (Bishop Heber College, 2024).

### **BHC Library**

The Bishop Heber College Library serves as a catalyst, facilitating the user community's scholarly exploration, learning endeavours, and the generation of novel ideas. Its wealth of robust information resources dedicated to teaching, learning and research plays a pivotal role in connecting individuals with intellectual growth and innovative pursuits. Library collection includes physical and electronic resources. The subscribed electronic resources can be accessed from on and off campus. The Library is fully automated using KOHA Open Source Library Management Software integrated with RFID technology, Self-Service Kiosk & Web OPAC.

### **Electronic Resources**

Through eSodh Sindhu consortium and NList, BHC library users have access to over 6000 e-journals and 1.99 lakh e-books. Subject lists for these resources will enhance the usage of resources by the patrons. In addition to the above, departmental repositories and open access resources are also included in the library information portal. In this context deployment of web based tool like Subjects Plus becomes handy for library users to locate and access resources and be able to interact with library staff team in case of further information needs.

### **Implementation of Subjects Plus**

The Bishop Heber College Library finds that SubjectsPlus software is an invaluable resource, especially when it comes to organizing the many databases that are accessible. With the wide variety of databases available to support different academic fields, the program makes subject guide creation easier and provides librarians with a useful tool. SubjectsPlus centralized database management features let librarian at Bishop Heber College Library arrange, classify, and display database content in an understandable way. Librarian may effortlessly explore and amend details in the subject guides because to their user-friendly interface, which guarantees that the guides are up to date and accurate representations of the wide range of resources available. By the use of the software's customization tools, subject guides may be made to specifically fit the requirements of Bishop Heber College Library, giving teachers and students access to carefully chosen material that is pertinent to their academic goals. All things considered, SubjectsPlus makes it easier to create subject guides for the many databases in the Library, improving accessibility and usefulness for the Bishop Heber College Library users.

BHC Library already has advanced technology and a wide selection of electronic resources. So the implementation of SubjectsPlus software is a strategic requirement in order to further improve its products and guarantee ongoing growth. Since SubjectsPlus is an open-source platform, it works very well with the library's mission to become innovative and efficient. Using the SubjectsPlus, the library can enhance its current electronic resources by adding personalized guides, tutorials, and educational materials, which promote a engaging the learning experience.

### **Subjects plus Implementation Stages**

Below listed steps are followed for implementation of Subjects Plus.

1. *Selection:* In this stage identification of resources on various discipline / subjects is carried out. In this process library staff would list the resources available in both print and electronic resources.
2. *Collection:* In collection stage, resources are gathered and listed according to the disciplines and topics. Use of standard subjects headings would be invaluable for library users. Important research tools, reference management tools, open access repositories and other useful tutorials are included.

3. *Evaluation*: In this stage the collected resources are reviewed and carefully evaluated for suitability and their currency.
4. *Organize*: After having reviewed and evaluated, the resources are organised systematically.
5. *Populate*: Relevant records for the above resources are populated in subjectsplus.

### **Conclusion**

SubjectsPlus software significantly enhances overall functioning and user experience if integrated into a library website. SubjectsPlus gives librarians the ability to construct dynamic and customized subject guides by providing a unified platform for resource administration, easy navigation, and extensive customization possibilities. Because of its collaborative capabilities, library staff members work together to keep the guides up to date and useful. An effective and cohesive library environment is further enhanced by the software's responsiveness and smooth integration with other library systems. In the end, SubjectsPlus demonstrates its versatility and indispensability as a tool for libraries, helping them better arrange, display, and make resources more easily accessible on their websites. This improves the overall level of assistance and service that libraries offer to their users.

### **References**

- [1] Bernier, R. (2010). Using Lib guides As a Web 2.0 Content Management System and a Collaboration Tool for Engineering Librarians. *2010 Annual Conference & Exposition Proceedings*, 15.1330.1-15.1330.13. <https://doi.org/10.18260/1-2--15634>
- [2] Bhavsar, S. (2018). *Role of Subject Guides in Academic Libraries*. 05(2394).
- [3] *Bishop Heber College*. (2024). <https://bhc.edu.in/files/index.php>
- [4] Blackburn, G., & Walker, M. (2010). Subject Guides & More: Creatively Transforming an Open Source Management System. *The Code4Lib Journal*, 12. <https://journal.code4lib.org/articles/4161>
- [5] Daws, C. (2016). Guiding Your Users to Library Resources: A Case Study of LibGuides at Charles Sturt University. *The ANZTLA E-journal*, 17, 52–62.
- [6] Manu, T. R., & Hasan, N. (2023). Evaluation and Creation of Web-based Resource Guides using SubjectsPlus. *Journal of Information and Knowledge*, 77–84. <https://doi.org/10.17821/srels/2023/v60i2/170964>
- [7] *SubjectsPlus*. (2024). Home Page. <https://subjectsplus.github.io/>

# Awareness and Perception of Plagiarism Among Post-Graduate Physical Sciences Students at North-Eastern Hill University

Bansharai Wartde<sup>1</sup> and Jiarlimon Khongtim<sup>2</sup>

<sup>1&2</sup>Dept. of Library and Information Science, North-Eastern Hill University, Meghalaya, India  
E-mail: banwrtde@gmail.com, jiarlikhongtim@yahoo.co.in

## Abstract

*This paper highlights the awareness and perception about plagiarism among the post-graduate physical sciences students in North-Eastern Hill University, Shillong. Out of 263 total numbers of students only 225 of them responded to the questionnaire distributed to them. The findings of the study revealed that majority of the students are familiar with the term plagiarism through internet. It was also found that very few students cite the resources they used in their work regularly whereas majority of them cite occasionally, rarely or never cite at all. Further, the study reveals that the main reasons for the students to plagiarise are lack of awareness, pressure to complete their work, lack of time, lack of original ideas, extra workload, and easy availability of information on internet which tempted them to copy.*

**Keywords:** Plagiarism and Physical Sciences Students, Awareness about Plagiarism, Plagiarism and Science Students, Plagiarism and Post-Graduate Students.

## Introduction

“Plagiarism is the act of copying someone else's words or ideas without that person's permission and passing them off as your own for the benefit of academic credit. It encompasses all text, manuscripts, and electronic material, both published and unpublished. It's possible to intentionally or accidentally plagiarise” (Walker, 2023). Plagiarism is an imperative issue in higher educational setting these days. Students in higher education institutions dealing with variety of academic information resources in different formats must also be aware of the legal and ethical issues attached with the information resources. Therefore, it is crucial that students must have knowledge about plagiarism and its consequences so that they will not fall prey to this crime. In India, the University Grants Commission (UGC) in its 2018 regulations had clearly stated about plagiarism in higher education and the penalty of the plagiarist. Thus, considering the importance to address this issue the present study is conducted to thoroughly evaluate the post-graduate science students' awareness and perception about plagiarism, their citation practise, and the circumstances in which they may be required to replicate the work of others.

## Review of Literature

Bukar, Maina and Jauro (2014) found that a high percentage of students have engaged in plagiarism in the past, with a majority of them doing it from the internet. Also, a significant proportion of students were either partially aware or completely unaware of plagiarism, with only a small percentage being aware of it. Finally, the study revealed that some students did not believe in punishing plagiarists. Gullifer and Tyson (2014) highlighted the issue of varying interpretations of plagiarism, leading to confusion among students and staff. The findings reveal that only half of the participants had read the plagiarism policy, indicating a lack of awareness. Moreover, confusion regarding what constitutes plagiarism was observed. A study conducted by Lines (2016) highlights that while Australian universities allow postgraduate students to seek professional editing for their theses, substantive editing is explicitly prohibited. This study discusses the challenges arising from this situation, as there is often confusion among students, supervisors, and editors regarding the boundaries between acceptable editing and substantive editing. It argues that

substantive editing is a significant yet largely neglected form of plagiarism, as universities perceive it as less serious and lack deterrents to prevent it.

Selemani, Chawinga and Dube (2018) explored the knowledge, forms, reasons, and consequences of plagiarism among postgraduate students at Mzuzu University in Malawi. It was found that the main reasons for plagiarised were pressure for good grades, laziness, poor time management, and lack of academic writing skills and a common forms of plagiarism reported include inadequate acknowledgement after paraphrasing, summarizing, and using quotation marks.

Hussein (2022) carried out a study which aims to assess the awareness of plagiarism among postgraduate students at Taif University. The findings indicated that postgraduate students have a moderate level of understanding regarding different forms of plagiarism and a high awareness of its causes. Another study by Phyo, Lwin, Tun, Mya and Silverman (2022) aimed to investigate the knowledge, attitudes, and self-reported practices of plagiarism among postgraduate students in Myanmar's universities. The findings suggested that plagiarism is an ethical issue in Myanmar, emphasizing the need for training in responsible conduct of research in universities.

Nketsiah, Imoro and Barfi (2023) in their study focused on the issue of plagiarism in higher education institutions, specifically in Ghana. The study highlights the lack of empirical research on students' knowledge of plagiarism and their experiences with text-matching technology. The findings indicated that there is no statistically significant relationship between postgraduate students' academic levels and their perception of plagiarism. However, there is a significant relationship between their perception of plagiarism and their use of Turnitin.

### **Summary of Literature Review**

From the literature reviewed, it was found that;

1. The postgraduate students have varying levels of awareness about plagiarism, with some being unclear about its distinctions and others engaging in plagiarism due to a lack of awareness.
2. The postgraduate students often face challenges in properly citing sources, leading to inconsistencies and potential plagiarism.
3. The reasons for plagiarism among postgraduate students vary, including inadequate understanding of plagiarism and its severity among students, goal orientation profiles and gender influencing attitudes towards plagiarism, pressure for good grades, laziness, poor time management, and lack of academic writing skills.

### **Objectives**

1. To examine the level of awareness about plagiarism among Post-graduate Physical Sciences Students in NEHU.
2. To identify the post-graduate science students' practise of citing information resources used.
3. To find out the reasons that made post-graduate science students to plagiarise.

### **Methodology**

The present study is conducted in the school of Physical Sciences in North-Eastern Hill University. There are four Departments within the school, namely Chemistry Department, Mathematics Department, Physics Department and Statistics Department. There are 263 total numbers of students studying in these four departments when this study was conducted. The detail number of students in each department is shown in the following table I:

TABLE I NUMBER OF STUDENTS IN EACH SEMESTER AND IN EACH DEPARTMENT

Department	2 <sup>nd</sup> Semester	4 <sup>th</sup> Semester	Total	No. of Respondent
Chemistry	37	34	71	58
Mathematics	40	36	76	68
Physics	31	34	65	50
Statistics	25	26	51	49
Total	133	130	263	225

263 questionnaires were distributed and only 225 filled in questionnaires were received back and used for the study. Thus, the respond rate is 85.5%.

### Data Analysis and Interpretation

TABLE II FAMILIARITY OF THE TERM 'PLAGIARISM'

Response	No. of Respondent	% of Response
Yes	141	62.7
No	84	37.3
Total	225	100%

The above table II shows that 62.7% of the students already know about the term 'Plagiarism' whereas 37.3% of them it is the first time they came to know about this term 'plagiarism'.

TABLE III MEANS OF FAMILIARISING THE TERM 'PLAGIARISM' BY THE STUDENTS

Means of familiarising	No. of Respondent	% of Response
Through the questionnaire	76	33.8
Through the conference	5	2.2
Through the Internet	129	57.3
Through a programme of education	6	2.7
Through newspapers, radio, and television	9	4
Total	225	100%

The above table III shows that 33.8% of the respondents are familiar with the term 'Plagiarism' through questionnaire, 2.2% are familiar through the conference, 57.3% are familiar with the term 'Plagiarism' through the Internet, 2.7% are familiar through programme of education, and 4% are familiar with the term 'Plagiarism' through newspapers, radio, and television.

TABLE IV PERCEPTION ABOUT PLAGIARISM IN GENERAL

Statement	No. of Respondent			% of Response		
	True	False	Total	True	False	Total
Copying from books/online sources without crediting the source constitutes plagiarism.	194	31	225	86.2	13.8	100%
If taking consent for copying from authors of the original source, but not giving references constitutes plagiarism.	155	70	225	68.9	31.1	100%
Translating from another language and presenting as one's own work constitutes plagiarism.	181	44	225	80.4	19.6	100%
Copied from the Internet but not citing the source constitutes plagiarism.	175	50	225	77.8	22.2	100%

The table IV shows that 86.2% of the students said that copying from books/online sources without giving credit to the source constitutes plagiarism and 13.8% of them said it is not. 68.9% of the students said that taking consent for copying from authors of the original source but not giving references constitutes plagiarism and 31.1% of them said it is not. 80.4% of the students said that translating from another language and presenting as one’s own work is plagiarism and 19.6% of them said it is not. 77.8% of the students said that copying from the Internet and not citing the source constitutes plagiarism and 22.2% of them said it is not.

TABLE V AWARENESS ABOUT TYPES OF PLAGIARISM AMONG THE RESPONDENTS

Response	No. of Respondent	% of Response
Self-plagiarism	67	29.8
Direct plagiarism	77	34.2
Unintentional plagiarism	42	18.7
Complete plagiarism	39	17.3
Total	225	100%

The table V shows that 29.8% of the students are familiar with self-plagiarism, 34.2% of them are familiar with direct plagiarism, 18.7% of them are familiar with unintentional plagiarism, and 17.3% of them are familiar with complete plagiarism.

TABLE VI UNDERSTANDING THE EFFECTS OF PLAGIARISM

Statement	No. of Respondent			% of Response		
	True	False	Total	True	False	Total
If anyone caught in plagiarism, he/she will be punished.	183	42	225	81.3	18.7	100%
Plagiarism can spoil the career of anyone.	159	66	225	70.7	29.3	100%
Self-plagiarism is likewise prohibited.	166	59	225	73.8	26.2	100%
Using plagiarism might result in a person losing their job.	160	65	225	71.1	28.9	100%
A person can be sent to jail due to indulging in plagiarism.	163	62	225	72.4	27.6	100%

TABLE VII WHETHER SOURCES ARE CITED CORRECTLY

Response	No. of Respondent	% of Response
Always	66	29.3
Often	64	28.4
Occasionally	63	28
Rarely	25	11.1
Never	7	3.1
Total	225	100%

From the table VI, it was found that 81.3% of the students understand that, if anyone caught in plagiarism, he/she will be punished and 18.7% of them do not understand about the effect of it. 70.7% of them understand that, Plagiarism can spoil the career of anyone and 29.3% of them do not agree about this. 73.8% of them understand that, Self-plagiarism is prohibited and 26.2% of them do not agree with this term. 71.1% of them understand that by using plagiarism a person might lose their job and 28.9% of them do not agree with this term. 72.4% of them understand that

a person can be sent to jail due to indulging in plagiarism and 27.6% of them do not agree with this term.

From the above table VII it was found that 29.3% of the students always cite the resources used in their work, 28.4% of the students often cite the resources while copying, 28% of the students occasionally cite the resources used, 11.1% of the students rarely cite the resources and 3.1% of the students never cite the resources while copying and used them in their work.

TABLE VIII CITATION STYLE USED FOR REFERENCES

Response	No. of Respondent	% of Response
MLA	33	14.7
APA	93	41.3
Chicago	39	17.3
None	60	26.7
Total	225	100%

The above table VIII shows that 14.7% of the students use MLA citation style while giving references, 41.3% of the students use APA citation style while giving references, 17.3% of the students use Chicago citation style while giving references, 26.7% of the students never use any citation style while giving references.

TABLE IX WHETHER REFERENCES ARE GIVEN WHEN PARAPHRASE CONTENTS

Response	No. of Respondent	% of Response
Always	65	28.9
Sometimes	142	63.1
Never	18	8
Total	225	100%

The above table IX shows that 28.9% of the students always give reference when they paraphrase others contents, 63.1% of them sometimes give reference when they paraphrase others contents, 8% of them never give reference when they paraphrase others contents.

TABLE X "PLAGIARISM SHOULD BE AVOIDED"

Response	No. of Respondent	% of Response
Strongly agree	47	20.9
Agree	79	35.1
Undecided	65	28.9
Disagree	28	12.4
Strongly disagree	6	2.7
Total	225	100%

From the above table X it was found that 20.9% of the students strongly agree about this phrase "Plagiarism should be avoided", 35.1% of them just agree about this phrase, 28.9% of them they can't decide to agree or disagree with it, 12.4% disagree about this term "Plagiarism should be avoided", and 2.7% strongly disagree with it.



TABLE XI PLAGIARISM AVOIDANCE

Statement	No. of Respondent			% of Response		
	Yes	No	Total	Yes	No	Total
I'll use quotations, references, and footnotes.	189	36	225	84	16	100%
I'll try to come up with my own ideas.	163	62	225	72.4	27.6	100%
I intend to improve my writing abilities.	192	33	225	85.3	14.7	100%
Before submitting an assignment/dissertation/research paper, I will run it through plagiarism detection software.	164	61	225	72.9	27.1	100%

From the above table XI, it seems that the students use different methods to avoid plagiarism. 84% use quotations, references, and footnotes, 72.4% said they will try to come up with their own ideas, 85.3% said they will improve their writing abilities, and 72.9% said they will use a plagiarism detection software before submitting an assignment or a dissertation or a research paper in order to avoid plagiarism.

TABLE XII METHODS USE TO IMPROVE THE UNDERSTANDING OF PLAGIARISM

Statement	No. of Respondent			% of Response		
	Yes	No	Total	Yes	No	Total
By enrolling in professional training programs.	180	45	225	80	20	100%
Through self-study (Books, Internet).	173	52	225	76.9	23.1	100%
By participating in conferences, seminars, and workshops.	195	30	225	86.7	13.3	100%

The above table XII shows that the students want to improve their understanding of plagiarism through different methods. 80% want to enroll in professional training programs, 76.9% through self-study, and 86.7% by participating in conferences, seminars, and workshops.

TABLE XIII MEANS OF ASSISTING POSTGRADUATE STUDENTS TO AVOID PLAGIARISM

Statement	No. of Respondent			% of Response		
	Yes	No	Total	Yes	No	Total
Do you require training to use plagiarism software?	179	46	225	79.6	20.4	100%
Do you think universities should hold a plagiarism seminar?	170	55	225	75.6	24.4	100%
Do you have any difficulties providing references/citations?	176	49	225	78.2	21.8	100%
Do you think universities should teach students how to properly cite useful resources?	189	36	225	84	16	100%
In spite of English not being your first language, do you have any trouble expressing yourself in English?	164	61	225	72.9	27.1	100%

The above table XIII shows that 79.6% of the students require training to use plagiarism software to avoid Plagiarism and 20.4% of the students do not require any training. 75.6% of the students think that universities should hold a plagiarism seminar in order to avoid Plagiarism and 24.4% of them are not aware about any of these. 78.2% of the students have difficulties in providing references/citations to avoid Plagiarism and 21.8% of them have no difficulties in providing references or citations. 84% of the students think that universities should teach students how to properly cite useful resources in order to avoid Plagiarism and 16% of them does not required any teaching to cite the sources. 72.9% of the students don't have any trouble in expressing themselves in English whereas 27.1% of them do have trouble.

TABLE XIV THE REASONS WHICH MADE THE POSTGRADUATE STUDENTS TO REPRODUCE  
THE WORK OF OTHERS

Statement	No. of Respondent			% of Response		
	Yes	No	Total	Yes	No	Total
When you are under pressure to complete the assignment/dissertation/research papers?	178	47	225	79.1	20.9	100%
Due to extra work load	203	22	225	90.2	9.8	100%
Laziness	151	74	225	67.1	32.9	100%
Lack of time	195	30	225	86.7	13.3	100%
It is hard to have original ideas	134	91	225	59.6	40.4	100%
Lack of interest in the topic of study	117	108	225	52	48	100%
Copying from the internet as the required information is easily available	187	38	225	83.1	16.9	100%

The above table XIV shows that 79.1% said that due to pressure to complete the dissertation/research papers whereas 20.9% does not have any problem with it, 90.2% is because of extra work load, 67.1% because of laziness, 86.7% because of lack of time, 59.6% express that they reproduced works of others because it was hard to have original ideas, 52% because of lack of interest in the topic of study, 83.1% accepted that they copied from the internet as the required information were easily available on the internet.

### Findings

1. Out of 225 respondents it was found that majority of the students already know about the term 'Plagiarism'.
2. It was found that the internet is the source of information about plagiarism for majority of the respondents and others learned about it from questionnaires, conferences, education programs, newspapers, radio, and television.
3. It was found that the respondents know about the different types of plagiarism.
4. It was also found that majority of the respondents know that plagiarism leads to punishment.
5. The study also reveals that only 29.3% of the respondents do cite the resources they used in their work regularly, and the rest of the respondents either they cite occasionally, rarely or never cite at all.
6. Further, it was also found that the reasons to plagiarise are due to the pressure to complete their assignments/dissertation/research papers, laziness, extra workload, lack of time, lack of original ideas, lack of interest in the topic, and due to the easily available of information on the internet.

### Conclusion

This study aimed to evaluate the awareness and perception about plagiarism among the post-graduate students in the School of Physical Sciences at NEHU. It also aimed to identify methods and tools for assisting students in avoiding plagiarism, provide recommendations for raising awareness and preventing plagiarism, and analyse the reasons why students choose to copy others' work when doing their assignments, dissertations or a research paper. The findings revealed varying levels of plagiarism awareness among the students under study, highlighting the need for increase education on academic integrity. One of the interesting finding of the present study is that even though majority of the students are aware about plagiarism and its consequences but still very few of them use citations for the resources they used in their work. This clearly indicates that the students are lacking knowledge on how to write citations and references, that is why

organising workshops and training programmes on plagiarism is essential. In this matter collaboration among the higher authorities of the university, faculties and the Library is required to enhance plagiarism awareness, encourage proper citation practices, and create an environment that values originality and ethical writing among the students community.

### **Recommendations**

Based on the findings of the study, the following recommendations are put forth:

1. It would be beneficial to organize workshops and training programmes that teach students about plagiarism, the consequences that come with it and more importantly on how to avoid plagiarism.
2. This responsibility can be taken up by the library in collaboration with the faculties of different departments.

### **References**

- [1] Bukar, A. M., Maina, M. B., & Jauro, S. S. (2014). Plagiarism: a perspective from a case of a Northern Nigerian University. Research Gate. [https://www.researchgate.net/publication/271704467\\_PLAGIARISM\\_A\\_PERSPECTIVE\\_FROM\\_A\\_CASE\\_OF\\_A\\_NORTHERN\\_NIGERIAN\\_UNIVERSITY#pf3](https://www.researchgate.net/publication/271704467_PLAGIARISM_A_PERSPECTIVE_FROM_A_CASE_OF_A_NORTHERN_NIGERIAN_UNIVERSITY#pf3)
- [2] Gullifer, J., & Tyson, G. (2014). Who has read the policy on plagiarism? Unpacking students' understanding of plagiarism. *Studies in Higher Education*, 39(7), 1202–1218. <https://doi.org/10.1080/03075079.2013.77741>
- [3] Hussein, M. G. (2022). The awareness of plagiarism among postgraduate students at Taif University and its relationship to certain variables. *Cogent Social Sciences*, 8(1). <https://doi.org/10.1080/23311886.2022.2142357>
- [4] Lines L. M. (2016). Substantive editing as a form of plagiarism among postgraduate students in Australia. *Assessment & Evaluation in Higher Education*, 41(3), 368–383. <https://doi.org/10.1080/02602938.2015.1013919>
- [5] Nketsiah, I., Imoro, O., & Barfi, K. A. (2023). Postgraduate students' perception of plagiarism, awareness, and use of Turnitin text-matching software. *Accountability in Research*, 1–17. <https://doi.org/10.1080/08989621.2023.2171790>
- [6] Phyoo, E., Lwin, T., Tun, H. P., Oo, Z. Z., Mya, K. S., & Silverman, H. (2022). Knowledge, attitudes, and practices regarding plagiarism of postgraduate students in Myanmar. *Accountability in Research*, 1–20. <https://doi.org/10.1080/08989621.2022.2077643>
- [7] Selemani, A., Chawinga, W. D., & Dube, G. (2018). Why do postgraduate students commit plagiarism? An empirical study. *International Journal for Educational Integrity*, 14(1). <https://doi.org/10.1007/s40979-018-0029-6>
- [8] Walker, J. (2023). What is Plagiarism? – A Comprehensive Guide. *Research Prospect*. <https://www.researchprospect.com/what-is-plagiarism-a-comprehensive-guide-for-students/>

# Exploring Open Source in Libraries: A Comprehensive Literature Review

Renald Moses<sup>1</sup>, Rohini Manikandan<sup>2</sup> and Anneruth<sup>3</sup>

<sup>1</sup>Assistant librarian, De Montfort University Dubai, Dubai International Academic City, UAE

<sup>2</sup>Librarian, Rajam Krishnamurthy Public School, Tiruchirappalli, Tamil Nadu, India

<sup>3</sup>Librarian, Apollo institute of allied sciences and hospital management, Tamil Nadu, India

E-mail: Renaldstark@gmail.com, Rohini1701k@gmail.com, Anneruth5543@gmail.com

## Abstract

*The purpose of this study is to find out the adoption and effects of open-source software (OSS) in library settings. In a survey on OSS adoption in Canadian small- and medium-sized libraries, Rathi (2018) covered subjects such product types, decision-making, and advantages. Oladokun and Kolawole (2018) examined Koha's potential in academic libraries in Nigeria, emphasizing its contribution to community engagement. The practical benefits of open source in libraries are highlighted by Puckett (2018). These benefits include improved security, collaboration, information assistance, and user-friendliness. The notion of library automation, integrated library resources, and the crucial function of the Library Automation System are all further introduced in the review. It explores the features of open-source software and its importance in the changing software landscape.*

**Keywords:** Library, Open-Source Software, Koha, Integrated Library Resources, Library automation, library management system.

## Introduction

A library is a selected collection of informational materials that are usually organized for easy access, usage, and retrieval. It serves as a knowledge store, allowing people to study, research, and access a wide range of content. Libraries play an important role in education, research, and community development. Here are some important elements of a library: Collections, Cataloguing and Classification, Services, Spaces, Digital Resources, Archives and Special Collections, Educational Support, Community Engagement.

Libraries play an important role in providing people with access to knowledge, information, and cultural resources. They serve a wide range of communities, from public libraries for local inhabitants to academic libraries that assist educational institutions. Library automation refers to the use of computer-based systems and technologies to streamline and improve various library processes. This includes cataloguing, circulation, acquisitions, and other administrative duties. Automation is intended to improve the efficiency of library operations, making it easier for librarians to manage collections and patrons to access information.

Integrated Library Resources are a unified and interconnected way to handling varied assets within a library. This includes books, periodicals, digital resources, multimedia elements, and so forth. An integrated system enables easy access and retrieval of multiple materials, giving library customers a more comprehensive experience.

A Library Automation System (LAS) is a software system for automating and managing a library's many operations. It often comprises modules for cataloguing, circulation, and acquisitions, as well as optional services like as online public access catalogues (OPAC), interlibrary loans, and reporting. Integrated Library Systems (ILS) and Library Management Systems (LMS) are frequent terms for such software.

## **Open-Source Software**

Open-source software is computer programs whose source code is freely available to the public. This means that anyone can read, edit, and distribute the code. The open-source concept emphasizes collaboration, openness, and community-driven development. Users are free to use, modify, and share the program without the restrictions of proprietary licensing. Open-source software has several key properties, including:

1. *Access to Source Code:* Users can view the underlying source code of the product, allowing them to understand how it works and make changes.
2. *Free Redistribution:* Users are free to distribute the software as is or with modifications, and there are no licensing fees.
3. *Community Collaboration:* Open-source programs frequently feature a community of developers and users who help to enhance the software. Collaboration can take place internationally and across several enterprises.
4. *Transparency:* The development process is accessible to public review, which promotes transparency and trust in the program.
5. *License Flexibility:* Open-source licenses vary, but most allow users to use, modify, and distribute the software. The Apache License and the GNU General Public License (GPL) are two popular open-source licenses.
6. *Popular Open-Source Software* includes the Linux operating system, the Apache web server, the Firefox web browser, and the MySQL database management system. Open source has become an essential component of the software ecosystem, supporting crucial infrastructure and propelling innovation.

Library automation is the use of computer-based systems and technology to streamline and improve certain library procedures and services. This covers responsibilities such as cataloguing, circulation, acquisitions, and patron management. The fundamental purpose of library automation is to increase the efficiency and effectiveness of library operations while also delivering better service to patrons. The key components of library automation are:

1. *Cataloguing and Classification:* Automation facilitates the construction and management of library catalogues. It entails the systematic organizing, description, and classification of library contents, making it easier for users to find and access resources.
2. *Circulation System:* Automation improves the flow of library materials. It handles borrowing, renewals, returns, and penalties in a more efficient and accurate manner, benefiting both library personnel and patrons.
3. *Acquisition and Inventory Control:* Automation facilitates the buying and management of library collections. It can manage acquisitions, monitor inventory, and help users select resources depending on their needs.
4. *Online Public Access Catalogue (OPAC):* OPAC is a user-friendly interface that allows patrons to search and access the library's collection online. Automation allows for the construction and maintenance of OPAC, making it a useful tool for users.
5. *Interlibrary Loan Services:* Automation streamlines interlibrary loan operations, allowing libraries to share resources more effectively.
6. *Digital Library and Electronic Resources:* Libraries are increasingly using digital materials and technological resources. Automation is critical to managing and accessing these digital collections.

Implementing library automation systems has various advantages, including increased accuracy, time efficiency, better user services, and improved resource discovery. It enables libraries to adapt

to the changing technology landscape and offer a more seamless experience to both staff and users.

### **An Integrated Library System**

An integrated library system is a computer-based system used to manage all the internal and external resources of the library. Many schools, colleges, institutions, and universities employ an integrated library system. It has a broader scope than the language library system because of its superior technology and functionalities.

*They help librarians in three ways:*

- a. It improves the operational efficiency of the library.
- b. It grants access to the library's collections.
- c. It enables access to external resources.

*The advantages of an integrated library system are:*

- a. Easy searching – It allows for online searches of library materials, resulting in quick and easy searches. Students prefer these digital libraries.
- b. Computerized services – It supports computerized library services, which facilitate inventory management.
- c. Web-based information – It offers a high-quality web-based information portal.
- d. User-friendly – It is a software that allows all functions to work smoothly.
- e. Full access provides extended access to library content. It efficiently provides full access to all library materials.

### **Koha**

Koha was the first free software library automation package. It is used all over the world and is being developed by a growing community of users who work together to achieve their technological goals. Koha's feature set evolves and expands to fulfil the needs of its users.

Full-featured ILS. Koha is a true enterprise-class ILS that is used in libraries of all sizes around the world. It has extensive capability, including basic and advanced features. Koha offers modules for acquisitions, circulation, cataloguing, serials administration, authority, customizable reporting, label printing, multi-format notices, offline circulation (when Internet connectivity is unavailable), and much more. Koha will work with consortia of all sizes, including multi-branch and single-branch libraries.

Library Standards Compliant. Koha is built on library standards and protocols including MARC 21, UNIMARC, z39.50, SRU/SW, SIP2, and SIP/NCIP, assuring Koha's interoperability with other systems and technologies while also supporting existing processes and tools.

Web-based interfaces. Koha's OPAC, circulation, management, and self-checkout interfaces are all built with standards-compliant World Wide Web technologies including XHTML, CSS, and JavaScript, making it a totally platform-independent solution.

In terms of awareness, Koha is becoming more well-known among India's librarians. This is due in part to the efforts of organizations and individuals who advocate for open-source solutions, as well as the Koha community's collaborative nature. Workshops, training sessions, and conferences are frequently used to raise awareness and enhance skills among librarians and information professionals. For the most up-to-date and precise information on Koha usage and awareness in India, visit Koha's official website, Indian library organization websites, or interact with local library professionals and institutions.

## Conclusion

In conclusion, library automation, particularly through integrated systems, uses technology to optimize library operations, improve user experiences, and assure the efficient administration of varied information resources inside a library. The study of open-source software concepts emphasizes their importance in fostering cooperation, improving security, and assuring usability. Popular software such as Koha exemplify the open-source ethos, which is renowned for its worldwide effect and versatility in contributing to the changing software ecosystem.

Finally, this assessment offers as a guide through the ever-changing terrain of library technology. It outlines the way to increased efficiency, collaboration, and accessibility through the use of open source, automation, and integrated technologies. As libraries continue to adapt to the digital age, the principles and solutions explored here pave the way for a future in which knowledge is not just preserved, but also conveniently accessible, shared, and enriched by communities around the world.

## References

- [1] Alikoba, E., Kiwelu, J. E. M., & Lwanga, E. (2019). *Factors Influencing the Acceptance and Use of Koha Library Software in Academic Libraries of Uganda*.
- [2] eLibrarySoftware. (n.d.). *Integrated Library System*. Retrieved from <https://www.elibrarysoftware.com/integrated-library-system.html>
- [3] *Koha Community*. (n.d.). Retrieved from <https://koha-community.org/>
- [4] Omopupa, K. T., Adedeji, A. A., Kehinde, A. A., Abdulsalam, A. U., & Abubakar, H. (2020). *Comparative Study of Koha Usage in Bowen University and University of Ilorin Libraries*.
- [5] Puckett, K. (2018). *Examining open-source software in libraries: Real-world advantages, increased security, teamwork, barrier-free information support, and user-friendliness*.
- [6] Punchihewa, C. N. D., & Kumara, A. D. B. (2015). *Open-source software adoption for library management: Issues and challenges*. University of Moratuwa, Sri Lanka. Email: nishanp@uom.lk, buddhink@lib.mrt.ac.lk.
- [7] Rathi, A. (2018). *Conducting a survey of small and medium-sized libraries in Canada: OSS product types, decision-making, support, benefits, etc.*
- [8] Ray, A. K. (2019). *Open-Source Software Solution for Library Management and Services: A Context-Based Scholarly Study*.
- [9] Salma, D. B. M. (2020). *Adoption of KOHA, Open Source of Integrated Library Management System: A Review of Literature*.

# Assessing Electronic Resource Utilization Among Undergraduate, Graduate, and Faculty Users in Engineering College Libraries of Coimbatore District

K. Subramanian<sup>1</sup> and Dr. G. Ulaganathan<sup>2</sup>

<sup>1</sup>Research Scholar, <sup>2</sup>Research Guide, Librarian & Head,

<sup>1&2</sup>Department of Library & Information Science,

<sup>1&2</sup>Dr. SNS Rajalakshmi College of Arts & Science, Coimbatore, Tamil Nadu, India

E-mail: libmanian@gmail.com, drgulaganathan@gmail.com

## Abstract

*This report describes the result done to ascertain the efficient use of electronic resources by undergraduate, graduate, and teacher users in Coimbatore District's engineering college libraries. In this study, the findings of a questionnaire-based survey that was done at a few chosen engineering institutions in the Coimbatore District are examined. E-resources must be incorporated into the collection management of specific engineering college libraries. These days, libraries have networked data that is connected to web-based services. Actually, integrating electronic services is the first step in introducing new services to libraries. Analysis was done on the information collected from the respondents via the surveys. A randomly chosen sample of 630 students and faculties received the questionnaire. Only 612 of the 630 questions were determined to be appropriate for this study, correspondingly representing the U. G., P. G., and Faculties 276, 182, and 154. This essay discusses the goals of using digital resources, how to get users to use them, and how to find them online. The findings show that faculty members, postgraduate students, and undergraduates at Engineering College Libraries effectively utilise e-resources.*

**Keywords:** Engineering Education, Digital Resources, Academic Libraries, knowledge dissemination, Retrieval method.

## Introduction

Libraries are Heart of the any educational institutions and which provides knowledge to the users. Digital resources are becoming a vital component of the higher education system. Education institutions invest more money in e-resource subscriptions in order to give library patrons effective service. Libraries will keep expanding in the future, according to the fifth law, which asserts that libraries are living, breathing and going organisms (Ranganathan, 1931). It is the responsibility of the library staff to understand how the e-resources are used and how they can improve the user's experience. This study surveyed faculty members and students to learn how they used e-resources in various disciplines. E - Resources are essential to the processes of teaching, research, and learning. The availability of electronic resources creates new opportunities for research, teaching, and learning. One of the many beneficial aspects of a university education is the ability to store, retrieve, and transmit information via electronic devices.

## Methodology

With an objective analysis of the data, the study aims to investigate how users in particular engineering colleges' libraries in Coimbatore zonal use e-resources. The study focused on the faculty and students, including research scholars, who use the e-resources in engineering colleges the most frequently. It is recommended that library and information professionals employ diverse techniques and methods to ascertain the information requirements of different user groups. In the research, one of the most powerful methods is survey approach. As a result, the current study used



a survey approach to determine how engineering students in a chosen group of private engineering colleges in the Coimbatore district use electronic resources.

### **Review of Literature**

Blessing of Ukachi, Ngozi (2023), carried out a study titled "Students' information literacy as a correlate of their use of electronic resources in Nigerian university libraries." According to the survey, the only resources available to library users are online databases, e-journals, e-books, OPACs, and the Internet. The questionnaire answers were confirmed by the interview data from the current study, which told the researcher that undergraduate students are not making good use of the ERs.

Sasikala, C., Dhanraju, V., and Nagarathomani, G. (2023): The academic community can access e-learning materials and other electronic resources through the libraries. The majority of libraries are found to be offering access to e-resources via UGC-INFLIBNET Consortia databases and institutional websites, as well as AICTE-INDEST Consortia databases. Additionally, this study shows that no library has a defined policy in place for creating e-resources. The majority of libraries obtain their electronic resources from publishers and providers. Additionally, the librarian recommends that funding be set aside specifically for the development of the library' e-resource collections.

When the epidemic made it impossible for people to attend libraries to study traditional sources, Deepmala (2022) made an effort at an online survey to investigate how people used electronic resources. This study showed that ICT speeds up the widespread use of e-resources. It also showed how reliant users are on electronic resources for many aspects of their lives, including research and teaching.

According to Larson and Agatha Gifty (2021), electronic databases are the foundation of any library, and libraries must invest a significant sum of money to acquire them. The findings demonstrate that most respondents knew how to use databases to get the information they needed, and that there were not many barriers preventing them from using the databases. Effective and efficient use of the databases was advised in very few cases.

The utilisation of electronic information resources by educators and students was examined by Venkateswarlu and Raja Suresh Kumar (2020). To collect data for this research, a survey was distributed to both faculty and students asking about their use of electronic information resources, their satisfaction with the services offered by the libraries, where to find pertinent information, and how satisfied they are with the level of satisfaction they get from their search for information.

The utilisation of electronic information resources by pharmacy students was discussed by Ramakrishna *et al.*, (2019). According to the report, the majority of students used electronic information resources for study and research, 20% for advancing their careers, and 17% for expanding their expertise. Additionally, it was discovered that most users used Google to look up electronic resources, with 42% using abstracting journals and 33% using the MEDLINE database.

Ahmed, S. M. (2017) The main objective of this study is to provide the results of a survey that was conducted in two public institutions in Bangladesh that offer specialised curriculum in order to assess how students use electronic information resources and how satisfied they are with the resources that they have subscribed to. A standardised questionnaire was used to assess how well the students used and felt about the electronic resources they had subscribed to through the institution. They also mentioned the primary problems they encountered when trying to access

online information. The survey's findings indicate that students are not at all satisfied with the calibre of the university's present online resource subscriptions. The pupils highlighted restricted computer access and sluggish download speeds as two of the key problems.

According to Priyadharshini and colleagues (2015), the original purpose of library extension was to offer traditional lending services to residents of growing cities and rural areas. Extension strategies were further developed to serve the needs of certain populations, such as the visually impaired, the homebound, and those in economic disadvantage. In the 1980s, when libraries started to use computers and improved telecommunications to satisfy the requirements of users who were seeking increasingly complicated information, the concept of a library extension gained additional significance.

### Goals for the Research

1. To ascertain how frequently users, utilize electronic resources.
2. To ascertain which types of electronic resources that users prefer.
3. To determine the objective of electronic resources.
4. To observe the e-resources searching strategy option for development.

### Information Analysis

Without interpretation, analysis is incomplete, and without analysis, interpretation cannot move forward. Therefore, both rely on one another. In line with the previously mentioned goals, a thorough analysis of the data that was gathered has been presented and discussed in this paper.

The Table I show that 134 Male students, 142 Female students responded in Undergraduate, 79 Male students, 103 Female students responded in Postgraduate, 91 Male and 63 Female responded in Faculties.

TABLE I GENDER WISE

Gender	Undergraduate		Postgraduate		Faculties	
	No. of Respondent	Percentage	No. of Respondent	Percentage	No. of Respondent	Percentage
Male	134	48.55	79	43.41	91	59.09
Female	142	51.45	103	56.59	63	40.91
Total	276	100.00	182	100.00	154	100.00

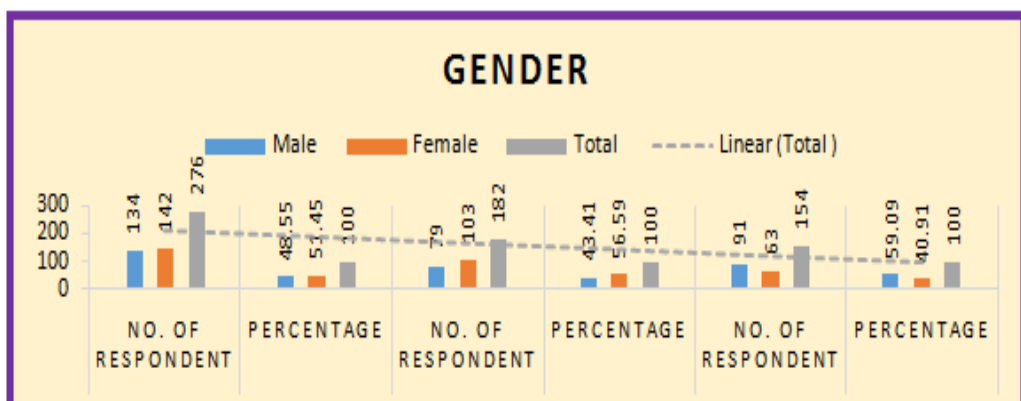

Fig. 1 Gender-Wise

Fig. 1 show that 48.55% Male students, 51.45% Female students responded in Undergraduate, 43.41 % Male students, 56.69 % Female students responded in Postgraduate, 59.09% Male and 40.91% Female responded in Faculties.

73 students are Computer related departments, 51 students are Communication departments, 49 students are Electrical & Embedded departments, 47 Students are Mechanical department and 56 students are Civil department undergraduate students are access e – resources. 94 students are Computer related departments, 21 students are Communication departments, 26 students are Electrical & Embedded departments, 19 students are Mechanical department and 22 students are Civil department postgraduate students are using e - resources. 38 faculties are Computer related departments, 28 faculties are Communication departments, 32 faculties are Electrical & Embedded departments, 29 faculties are Mechanical department and 27 faculties are civil department staff members are using e - resources.

TABLE II DEPARTMENT WISE ACCESS THE E - RESOURCES

Course wise	Undergraduate		Postgraduate		Faculties	
	No. of Respondent	%	No. of Respondent	%	No. of Respondent	%
Computer Science, MCA	73	26.45	94	51.65	38	24.68
Communication Engineering	51	18.48	21	11.54	28	18.18
Electrical & Embedded Engineering	49	17.75	26	14.29	32	20.78
Mechanical Engineering, CAD / CAM	47	17.03	19	10.44	29	18.83
Civil & Structural Engineering	56	20.29	22	12.08	27	17.53
Total	276	100.00	182	100.00	154	100.00

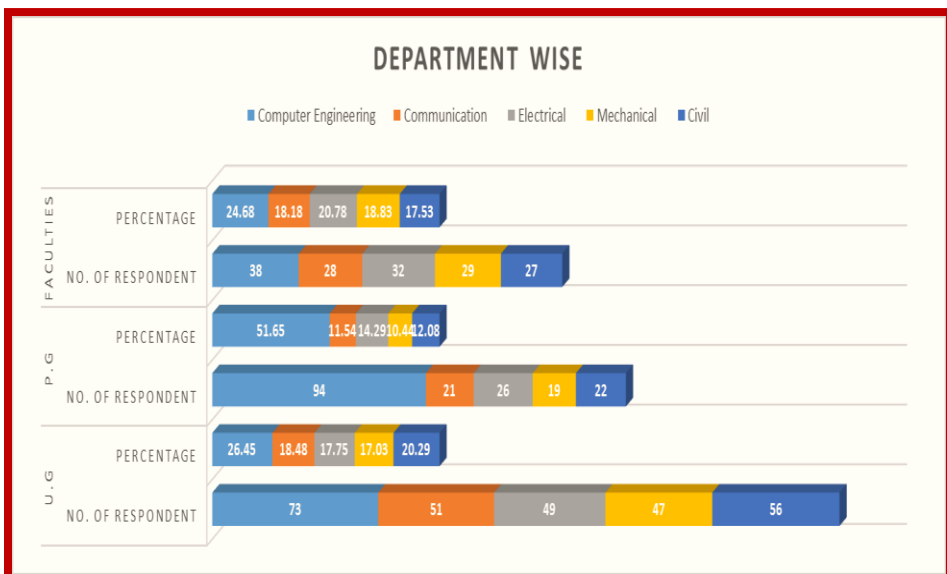

Fig. 2 Department Wise

The above Fig. 2 shows that 26.45% of students are Computer related departments, 18.48% of students are Communication departments, 17.75% of students are Electrical & Embedded departments, 17.03% of Students are Mechanical department and 20.29% of students are Civil department undergraduate students are access e - resources. 51.65% of students are Computer related departments, 11.54% of students are Communication departments, 14.29% of students are Electrical & Embedded departments, 10.44% of students are Mechanical department and 12.08% of students are Civil department postgraduate students are using e - resources. 24.68% of faculties are Computer related departments, 18.18% of faculties are Communication departments, 20.78% of faculties are Electrical & Embedded departments, 18.83% of faculties are Mechanical department and 17.53% of faculties are civil department staff members are using e - resources

This is the most significant and fundamental part of the evaluation and utility of e-resources. As a result, an attempt is made to quantify the regularity with which electronic resources are accessed. 24 students daily, 39 students weekly, 47 students fortnightly, 94 students monthly and 72 students occasionally used e – resources for undergraduate students. 32 students daily, 51 students weekly, 43 students fortnightly, 35 students monthly and 21 students occasionally used e – resources for postgraduate students. 16 faculties daily, 29 Faculties weekly, 24 faculties fortnightly, 57 faculties monthly and 28 faculties occasionally used e-resources.

TABLE III FREQUENCY OF LIBRARY VISITS

Frequency	Undergraduate		Postgraduate		Faculties	
	No. of Respondent	Percentage	No. of Respondent	Percentage	No. of Respondent	Percentage
Daily	24	8.69	32	17.58	16	10.39
Weekly	39	14.13	51	28.02	29	18.84
Fortnightly	47	17.03	43	23.63	24	15.58
Monthly	94	34.06	35	19.23	57	37.01
Occasionally	72	26.09	21	11.54	28	18.18
Total	276	100.00	182	100.00	154	100.00

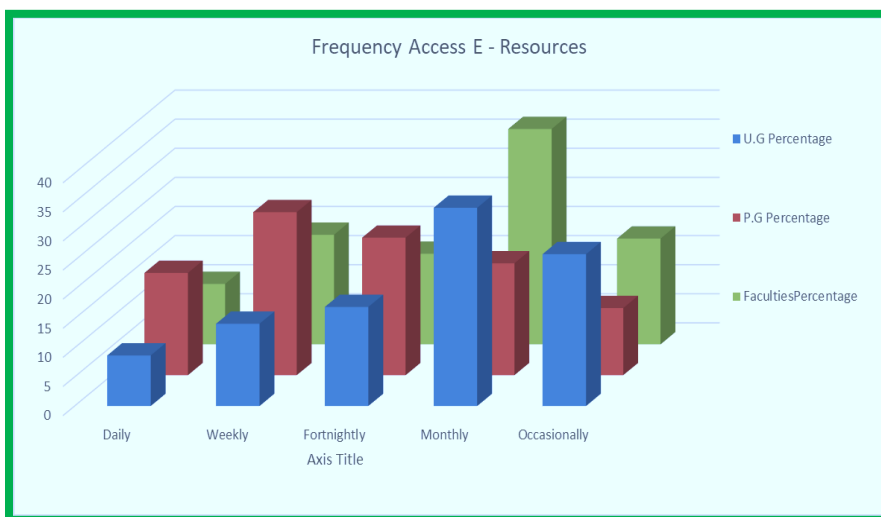

Fig. 3 Frequency Access E-Resources

From Fig. 3 we can know that 8.69% of students daily, 14.13% of students weekly, 17.03% of students fortnightly, 34.06% of students monthly and 26.09% of students occasionally used e - resources for undergraduate students. 17.58% of students daily, 28.02% of students weekly, 23.63% of students fortnightly, 19.23% of students monthly and 11.54% of students occasionally used e - resources for postgraduate students. 10.39% of faculties daily, 18.84% of faculties weekly, 15.58% of faculties fortnightly, 37.01% of faculties monthly and 18.18% of faculties occasionally used e – resources.

According to Table IV, 57 students are paper publication, 68 students are course work, 54 students are project work, 61 students are updating knowledge and 36 students are other works in undergraduate students are using the E - Resources. 51 students are paper publication, 43 students are course work, 54 students are project work, 13 students are updating knowledge and 21 students are other works in postgraduate students are using the E - Resources. 39 faculties are paper publication, 24 faculties are course work, 54 faculties are project work, 18 faculties are updating knowledge and 19 faculties are other works in faculty members are using the E – Resources.

TABLE IV PURPOSE OF ACCESSING E - RESOURCES

S. No.	Purpose	No. of Respondent U. G	%	No. of Respondent P. G	%	No. of Respondent Faculties	%
1	Publication of papers	57	20.65	51	28.02	39	25.32
2	Studying course work	68	24.64	43	23.63	24	15.58
3	Research / Project work	54	19.57	54	29.67	54	35.07
4	Updating knowledge	61	22.10	13	07.14	18	11.69
5	Any other works	36	13.04	21	11.54	19	12.34
	Total	276	100.00	182	100.00	154	100.00

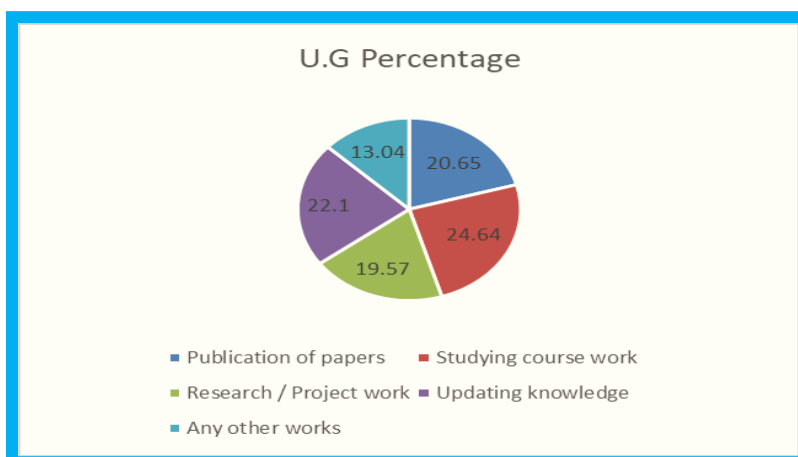

Fig. 4 Purpose of U.G Students visiting the library

From Fig. 4, 20.65% of students are paper publication, 24.64% of students are course work, 19.57% of students are project work, 22.1% of students are updating knowledge and 13.04% of students are other works in undergraduate students are using the E - Resources.

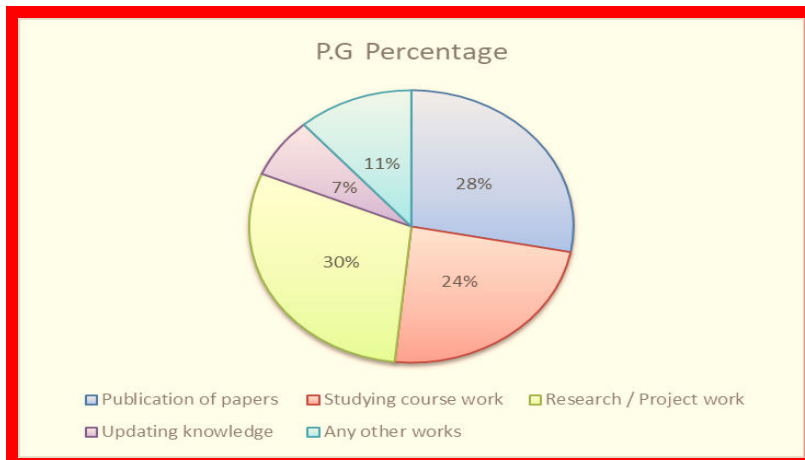

Fig. 5 Purpose for P.G Students

From Fig. 5, 28% of students are paper publication, 24% of students are course work, 30% of students are project work, 7% of students are updating knowledge and 11% of students are other works in postgraduate students are using the E - Resources.

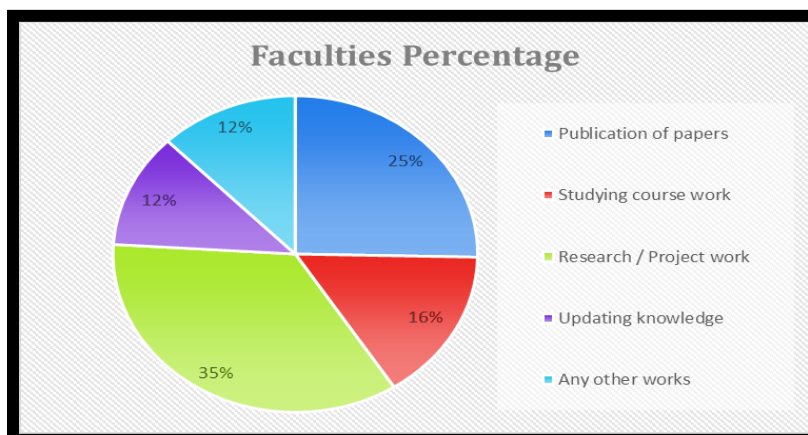

Fig. 6 Purpose for Faculties

From Fig. 6, 25% of faculties are paper publication, 16% of faculties are course work, 35% of faculties are project work, 12% of faculties are updating knowledge and 12% of faculties are other works in staff members are using the E - Resources.

From table V we know that among undergraduate, 29 students are poor connectivity, 42 students are not relevant information, 38 students are library time is not suitable, 52 students are Lack of system admin support, 74 students are non-availability of full access, 41 students are update latest software faced the issues while using the e – resources. In postgraduate, 13 students are poor connectivity, 24 students are not relevant information, 17 students are library time is not suitable, 36 Lack of system admin support, 53 students are non-availability of full access, 39 students are needing update latest software faced the issues while using the e - resources. Among faculties, 13 faculties are poor connectivity, 16 faculties are not relevant information, 27 faculties are library time is not suitable, 22 faculties are Lack of system admin support, 47 faculties are non-

availability of full access, 29 facilities are needing update latest software faced the issues while using the e – resources.

TABLE V PROBLEMS WHILE USING E – RESOURCES

S. No.	Problems	No. of Respondent U. G	%	No. of Respondent P. G	%	No. of Respondent Faculties	%
1	Poor Connectivity (Slow Speed)	29	10.51	13	07.14	13	08.44
2	Difficulty in finding relevant information	42	15.22	24	13.19	16	10.39
3	Library time is not suitable	38	13.77	17	09.34	27	17.53
4	Lack of system admin team	52	18.84	36	19.78	22	14.29
5	Non availability of full access Subscription	74	26.81	53	29.12	47	30.52
6	File format and update latest software	41	14.85	39	21.43	29	18.83
	Total	276	100.00	182	100.00	154	100.00

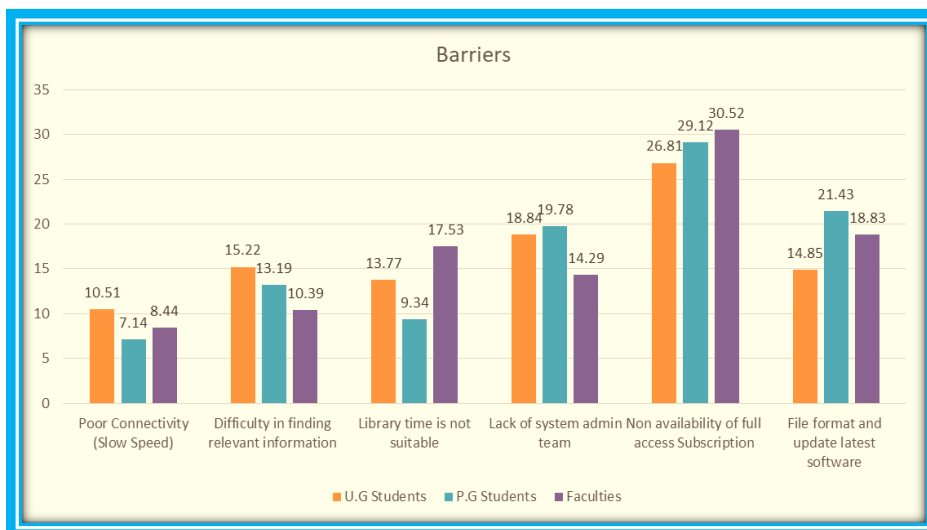

Fig. 7 Problems While Using E – Resources

From Fig. 7, we know that among undergraduate, 10.51% of students are poor connectivity, 15.22% of students are not relevant information, 13.77% of students are library time is not suitable, 18.84% of students are Lack of system admin support, 26.81% of students are non-availability of full access, 14.85% students are update latest software faced the issues while using the e – resources. In postgraduate, 07.14 students are poor connectivity, 13.19 students are not relevant information, 09.34 students are library time is not suitable, 19.78 Lack of system admin support, 29.12 students are non-availability of full access, 21.43 students are needing update latest software faced the issues while using the e - resources. Among facilities, 08.44 facilities are poor connectivity, 10.39 facilities are not relevant information, 17.53 facilities are library time is not suitable, 14.29 facilities are Lack of system admin support, 30.52 facilities are non-availability of full access, 18.83 facilities are needing update latest software faced the issues while using the e – resources.

## Discussion

1. E-resources encompass various digital materials, including e-books, online journals, databases, multimedia content, and educational websites, providing students and faculty with vast amounts of information at their fingertips.
2. Keeping in mind the ever-changing needs of library users, management-based library services must be continuously updated.
3. E-resource Consortia: Collaborative efforts among educational institutions have led to the establishment of E-resource consortia, allowing member colleges to access a wider range of digital resources at reduced costs.
4. E-resources facilitate international collaboration among students and faculty by breaking down geographical barriers and enabling knowledge sharing with peers worldwide. Institutions must ensure proper compliance with copyright laws and licensing agreements while providing access to copyrighted materials.

## Conclusion

Online resources services use the success of an educational. Integration of Learning Management Systems (LMS): Engineering colleges are increasingly integrating E-resources with their LMS platforms, creating a centralized hub for accessing course materials, lectures, and supplementary resources. It is highly useful for self-learning. Open Educational Resources (OER): OER, which are freely accessible educational materials, have gained popularity in Indian engineering colleges, promoting open access to knowledge. While the benefits are evident, challenges such as the digital divide and technical issues must be addressed to ensure equitable access to quality education. By embracing emerging technologies and collaborative initiatives, engineering colleges in India can continue to harness the potential of E-resources to enrich the learning experiences of their students and faculty.

## References

- [1] Dhanavandan, S., Tamizhchelvan M., (2012). Use Pattern of Digital Resources Among Engineering Colleges in Tamil Nadu, India”, *International Journal of Library Science*, 5 (1) 2012. P.30-40.
- [2] Ganski, Kate L. (2008). An Evaluation of the Accessibility of E-resources from Theological Library Websites. *Theological Librarianship: An Online Journal of the American Theological Library Association*, 1 (1). 38-45.
- [3] Girish Kumar H., Vasant R. & Praveen J.K., (2005), Use of electronic resources by research scholars in CFTRI, Mysore: A study. *ILA Bulletin*, 41(3), 16-20.
- [4] Jagdish Arora and Kruti Trivedi. (2010) INDEST-AICTE Consortium: Present Services and Future Endeavours ,*DESIDOC Journal of Library & Information Technology*, Vol. 30, No. 2, March 2010, pp. 79-91
- [5] K.N.Kandapal, S.S Rawat and K.S.R Vithal, (2013) Use of E-resources by Undergraduate Students of NTR College of Veterinary Science, Andhra Pradesh, *DESIDOC J.Lib*, Vol.33, No.5, pp.394-398.
- Kanniyappan, E., Nithyanandam, K. and Ravichandran, P. (2008). Use and impact of e - resources in an academic and research environment: a case study. *Information Studies*, 14 (3). 151-162.
- [6] Kaur, Baljinder and Verma, Rama. (2009). Use of Electronic Information Resources: A Case Study of Thapar University. *The Electronic Library*, 27 (4). 611-622.
- [7] Madhusudhan, Margam. (2010). Use of Electronic Resources by Research Scholars of Kurukshetra University. *The Electronic Library*, 28 (4). 492-506.



# Intellectual Repositories in Institutions of Higher Learning with Special Reference to D-Space and E-Prints

Sanjay Kumar Jha<sup>1</sup> and Dr. Ashok Kumar Upadhyay<sup>2</sup>

<sup>1</sup>Research Scholar, <sup>2</sup>Librarian & Associate Professor,

<sup>1&2</sup>Department of Library and Information Science, Manglayatan University, Uttar Pradesh, India

E-mail: jhasanjay4@rediffmail.com, ashoka143@gmail.com

## Abstract

*The digital landscape offers an environment that is favorable to enabling swift and obvious advancements in the products, services, and delivery system. With the aid of the digital environment, the divide between the economy and society is quickly closed. Open access is a strategy to address the issue of inaccessibility, which is mainly caused by financial limitations, especially in developing nations. It makes scholarly communication more readily available and easier to distribute. The benefits of open access have gradually become apparent to different institutions in India. Numerous open-access projects have been started and are currently running. This paper discusses the idea of an intellectual repository (IR), as well as the role that librarians, the intellectual community, educational institutions, and the government play in creating and maintaining IRs, as well as their necessity, significance, and benefits. It also gives a summary of the Intellectual Repository (IR) programs that selected Indian higher education institutions have put in place.*

**Keywords:** Institutional Repository, Electronic Digital Content Management System, Digital preservation, D-Space, Digital libraries, Indian libraries, Open-source software

## Methodology

An interview method is used (telephonic or personal), to collect data from selected academic institutions. The author asked a series of informal questions to obtain knowledge and also visited the university library website

## Introduction

The Institutional Repository (IR), one of the key elements of the digital environment, has been the subject of discussion and debate among librarians, information scientists, academicians, and administrators on professional platforms to maximize the observable benefits and achieve excellence in their respective fields. One significant development in the field of information technology adoption is open-source software, or OSS (Marsan *et al.*, 2012). The OSS movement has changed the fundamental characteristics of the software sector (Fitzgerald, 2006). This movement has increased public awareness of issues like open access and open content while also producing large amounts of valuable software (Krishnamurthy, 2008). Due to its widespread adoption by corporations, academic institutions, government agencies, and individual users, open-source software (OSS) has had a significant impact (De, 2009). Because open source software (OSS) is less expensive than commercial software, it is becoming more widely recognized as a tool that can assist governments in achieving effective service delivery (Mutula and Kalaote, 2010). In addition to reducing software development time and improving software quality, open-source software (OSS) applications created by volunteer software development teams have the potential to end the current dominance of proprietary software and restrictive licenses for many business applications. Most importantly, though, OSS applications can make critically important software applications more affordable for individuals and small businesses that would not otherwise be able to afford them (Nagy *et al.*, 2010). The Intellectual Repository (IR) is a significant element of the digital environment. Librarians, information scientists, academicians,

and administrators have been discussing and debating IR on professional platforms to maximize observable benefits and achieve excellence in their respective fields. Libraries and information centers around the world are particularly affected by the digital environment because they are no longer viewed as book storage facilities but rather as portals to knowledge and hubs for scholarly creation and recreation. It goes on to say that knowledge has been preserved in a variety of media, including papyrus, scrolls, paintings, rock scripting, clay tablets, and contemporary chip technology. For centuries, the ancient scholars who created the corpus of knowledge withheld it from the public. Nearly 75% of the population in ancient India did not have access to the Vedas, which are regarded as the repository of knowledge. Not everyone has access to information about nuclear energy, even in the modern day. Similarly, knowledge and books become the property of an individual and are not available to the general public.

The idea behind public libraries' creation and growth has always been to democratize knowledge. The industrialized nations dominate the mass media and have monopolized the channels and means of information distribution. Globally, the major publishing houses dominate research and its publications. Because of the financial crisis, developing nations are unable to maintain their knowledge hubs. The majority of people prefer free things. It is human nature. The inclination or need for free things has grown to be a major source of worry, and researchers are looking for answers to understand why people want free access to knowledge. An answer to the thirst for knowledge, particularly for those who have been denied it for a variety of reasons, is the Intellectual Repository. Recent years have seen a significant advancement in the process of empowering academics and researchers through knowledge sharing in the form of IR.

### **Concept of Intellectual Repository (IR)**

An IR is a system where people with similar interests agree to share the contributions they own, which may take the form of articles, research papers, etc. It is seen as the collective wealth of members of that kind of group. Once the contributor contributes the article, they forfeit their ownership of the knowledge, making it accessible to others who require the relevant information. The recipients pay nothing and break no laws to enjoy the excellent writings of renowned authors. An intellectual repository is thus a living combination of different activities, such as writing articles for the repository, interacting with it, and helping to construct it.

Lynch Clifford (2003) shares his opinions regarding the Intellectual Repository, "a university-based institutional repository is a set of services that a university offers to the members of its community for the management and dissemination of digital materials created by the institution and its community members. It is most essentially an organizational commitment to the stewardship of these digital materials, including long-term preservation access or distribution." Lynch uses the word "community" here, which is crucial. While repository developers may have different interpretations of what a community-based service is, the term institutional repository suggests one.

### **Needs of Intellectual Repository**

India is emerging from the shadows of backwardness and the suffering of the Less Developed Country (LDC), so support for her sustenance is required from all spheres of the intellectual community. Finding alternatives to address these issues is necessary given the declining financial support, rising reading material costs, and managerial mindset and attitude patterns in higher education institutions. The term "Intellectual Repository" would be a more fitting and all-encompassing replacement for "Institutional Repository". Since there is currently no way to measure the quality of intellectual output for publishers and contributors, this system allows for

that to happen. Thus, to explore a network of intellectual repository access, there is a great need for these kinds of repositories in higher education institutions.

### **Benefits of Intellectual Repository**

Prosser (2003) highlights the benefits of Institutional repositories as under Institutions can create archives and make their wealth of knowledge available by using the institutional repository model. It enables individuals to self-archive their work, including researchers and scientists. For the researchers, the institutional repository serves as a central repository for their work, akin to a resume that offers a comprehensive overview of their body of work over time. The fact that it is open access broadens the reach and influence of their work.

1. It serves to protect academic institutions' intellectual capital. It raises their profile and status and serves as a kind of advertisement for corporate sponsors and funding sources.
2. It ensures the long-term preservation of research and gives society access to the world's research.

### **IR Initiatives in the Indian Scenario**

Since many prestigious institutions, including IITs, IITs, IISc, and universities, have already adopted the initiative of IR, India is not falling behind in the creation of intellectual repositories. These organizations and universities are receiving assistance in creating intellectual repositories from several governmental and professional organizations. The Knowledge Commission (KC), recently established by the Indian government, will create a precise road map that Indian higher education institutions can follow to implement projects like renovating libraries and constructing intellectual repositories. Similarly, the University Grant Commission (UGC) has already established the Information Library Network (INFLIBNET), a distinct organization, to modernize libraries and establish knowledge centers so that people can access and exchange the vast body of research knowledge. The INFLIBNET provides specialized training and library networking to its member institutions and universities to help them select, manage, preserve, and distribute scholarly materials. The modernization of libraries, training, and establishment of IRs are also undertaken by several professional associations and societies, including the "Indian Library Association (ILA)", the Developing Library Network ("DELNET"), and the "Society for Advancement of Library & Information Science (SALIS)". A glance at the growth of IR in India can be found in the table below:

### **IR at Learning Resource Centre, O.P. Jindal Global University**

The O.P. Jindal Global University, Sonapat (Haryana) is a leading university in the field of social science in India. JGU (Jindal Global University), Institute of Eminence views its mission as providing its faculty and students with the scholarly research, knowledge, and skills necessary to meet the demands and challenges of globalization. The university's Global Library has been modeled after prestigious academic institutions around the globe, including "Harvard, Yale, Oxford, and Cambridge". The goal of the library is to support the university's outreach, research, and teaching initiatives by giving users access to current global information sources and educational materials via cutting-edge technology and services. This university produces a great deal of intellectual property in the form of research papers, project reports, books, conference papers, theses, dissertations, and articles from its faculty, research scholars, staff, and students. It must be maintained, managed, and made available to the community and society for people to share and visualize their innovations. The university library named Global Library has taken the lead in creating an intellectual resource (IR) model for community management, preservation, and dissemination. The "PURE" model of IR (E-print) has been developed. At first, it can be accessed via a local area network, but now it is accessible through the internet from anywhere.

TABLE I STUDY OF IR IN SELECTED EDUCATION INSTITUTIONS

Name	Host Institution	URL	No. of Items	Types of Documents	IRs used
Pure Publication Repository	“O. P. Jindal Global University”	https://pure.jgu.edu.in/	6132	“Research papers, dissertation, thesis, articles, project Reports, Previous year question papers”	E-prints
Digital Repository Service @ BU (DRS@BU)	“Bennett University, Greater Noida (UP)”	https://lrcdrs.bennett.edu.in	1555	“Research papers, dissertation, thesis, articles, project Reports”	D-space
EPrints@IITD	“Indian Institute of Technology, Delhi(IITD)”	http://eprint.iitd.ac.in/	9246	“Research Papers, Articles, Reports, etc”	D-space
D-space at Ashoka University	“Ashoka University”	https://dspace.ashoka.edu.in	3500	“Research papers, dissertation, thesis, articles, project Reports”	D-space

A screenshot of the IR model is given below.

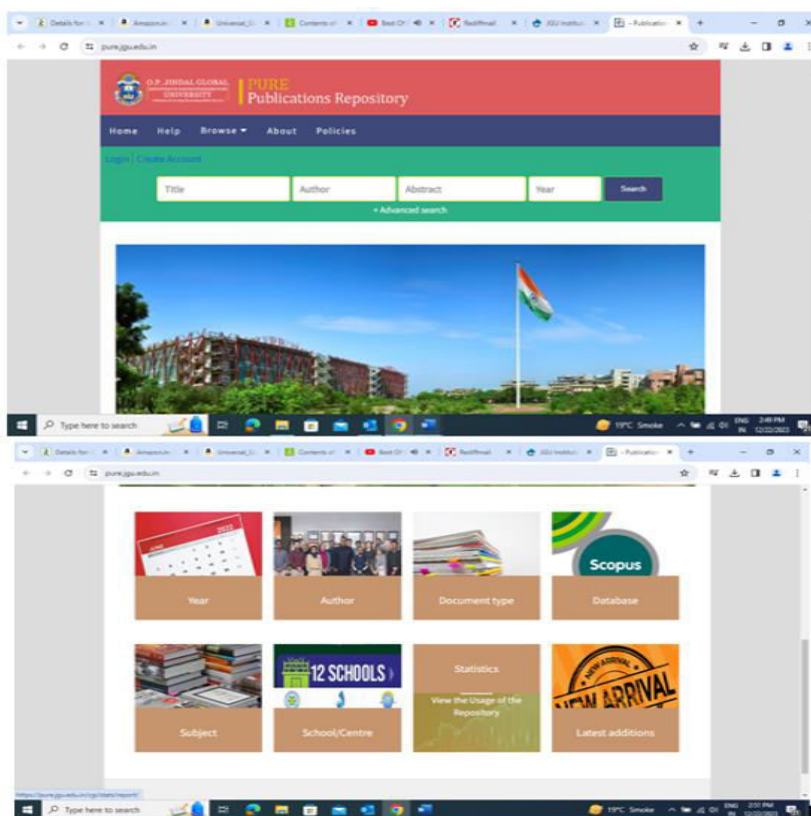

Fig.1 Homepage of Pure Publications Repository

### **Critical Issues Related to IR**

Some critical issues have been identified during the experiment of IR at O. P. Jindal Global University. Prior to taking action in the relevant institutions, it is imperative to keep these issues in mind. These include issues with copyright, a lack of expertise, developing capacity, choosing hardware and software, digitizing content, committing the organization, and content selection, among other things.

### **Major Problems of Intellectual Repositories in India**

Before starting any kind of intellectual repository initiative, the goals of the participating institution and the initiative itself are taken into consideration during the planning stage. Then a prototype is developed, tested, and implemented. The intellectual repository is developed, implemented, and tested again on a larger scale following the attainment of satisfactory results. For a variety of reasons, some institutional repositories that have been visited in order to obtain information are not currently available online.

### **Selected Problems and Solutions of IR Initiative**

As previously stated, traditional thinking is deeply ingrained in the manager's and management's mindset and attitude. It is quite challenging to persuade the management that IR is required. Some areas of mindset and the solutions for overcoming them are as follows:

#### *1. Mind Set of Authority*

Usually, the proposal for an intellectual repository is made by the librarian. When discussing the issue without a librarian, the higher authority of the institutions is hardly persuaded that the librarian can do this extraordinary intellectual work. It's because society hasn't given the library profession the proper recognition yet, but the new generation of librarians, who are highly intelligent, technically sound, technologically savvy, open-minded, and dedicated to the field are now prepared to take the next step. Thus, it is this generation's responsibility to persuade the higher authority.

#### *2. Lack of Presentation Skills*

It has been observed that over the decade, librarians' presentation skills have been noticeably lacking. As a result, they are unable to persuade the authorities in their respective organizations to adopt initiatives like IR. Because of this, there is a perception that librarians are completely unsuited to assume new roles. The younger generation of librarians must alter this perception. The best possible representation of the project should be given to the higher authority using audio-visual aids and other presentation tools.

#### *3. Financial Crunch*

The authorities do not provide more funding for innovation and expansion unless the project is crucial to the organization and society. Librarians of the new generation should make their case in a way that will demonstrate how the investment will benefit the institutions/organization down the road. It is also possible to suggest that the alternative budgeting approach and the potential revenue from different sources be taken into account.

#### *4. Introspection by the Librarians*

In addition to being connected to authority, mental health issues and attitudes are also closely linked to librarians. It should be mandatory for librarians to challenge conventional wisdom and transform them into positive role models. Sometimes, for a variety of reasons, the authorities are unable to approve the proposal because of their limitations. The librarians shouldn't believe that their proposal isn't being accepted by the authorities.

## *5. Problems after Taking Initiatives*

### *a. Acceptability*

Obtaining acceptance or approval from the institute/university authority to set up the institutional repository is one of the main challenges facing library and information professionals. Second, getting faculty members and research scholars' research output into the university's or institute's intellectual repository is extremely challenging. The intellectual community may not always be persuaded by library professionals of the value of intellectual repositories and their role.

### *b. Visibility*

Many organizations, including university libraries, the Indian Defense Research and Development Organization (DRDO), and other research institutions, have set up intellectual repositories, but it has been observed that they have no interest in sharing the same with the public.

### *c. Sustainability*

Establishing an institutional repository requires a significant amount of work and money, making it a time-consuming and challenging process. Thus, to ensure long-term preservation, the IR must be maintained and sustained. The content review, hardware updates and revisions that maintain accessibility and other tasks are included in the maintenance portion. The majority of institutions and universities are not promptly updating, reviewing, and maintaining their IR, according to the web survey results.

### *d. Accessibility*

- i. Although the Uniform Resource Locator (URL) is updated on web pages, it is not updated regularly.
- ii. The web server is not always up and running because of power issues and other unobservable factors.
- iii. The webpage update and the service termination occur at an entirely different time.
- iv. The server may occasionally stop working because of inadequate maintenance.
- v. To reduce these issues, the librarians in charge of keeping up intellectual repositories should examine them regularly. To make resource materials easier to use, they can ask for user feedback.

## **Lesson Learnt**

Various insights have been gained from a review of the literature, an analytical web survey, and interviews with specialists, and experiments conducted at O. P. Jindal Global University. These insights could prove beneficial for other comparable higher education institutions.

### *1. Organizational Commitment*

The organization needs to show a strong commitment, along with adequate infrastructure and preparation. It has been discovered that the majority of existing information repositories (IRs) were started by libraries and information centers (LIC), but academic institutions do not support LICs when it comes to contributing their intellectual property. In this case, the organizations have to persuade their researchers and faculty members to contribute their intellectual property to the repository. Contributors ought to receive appropriate recognition.

### *2. Well Defined Policy*

Institutions ought to create a clear IR policy wherein some crucial questions should be addressed and decisions made. Content selection, content submission and review, licensing

guidelines, copyright concerns, author agreements, etc. are among the concerns. Without methodical planning, success is unattainable for anyone. Therefore, it is recommended that the authority clearly define the IR policy.

### 3. *Selection of Hardware and Software*

A key factor in the development of IR is the software choice. Similarly, the newest hardware is required to support the IR for long-term sustainability. Standard criteria such as network configuration, customization, a standard database management system, a user-friendly interface, etc. should be used when choosing software. Analogously, modern hardware with adequate speed and storage should be used. During the web survey, it was discovered that certain IRs are unavailable around the clock for various reasons, including server load capacity and inadequate bandwidth.

### 4. *Selection of Content*

The content is crucial because high-quality content adds value to the repository and raises the organization's profile and visibility. As a result, it is advised that the contents be carefully chosen and examined by subject matter experts.

### 5. *Periodical Training*

To ensure optimal use and better outcomes, all staff members and users of the repository should receive proper training; otherwise, all the investment and effort put into IR will be in vain.

### 6. *Critical Review and Feedback*

The feedback and critical review assist the IR developers in understanding the shortcomings and shortcomings of the system. During the web survey, it was discovered that many IRs are not routinely reviewed and maintained following implementation. For this reason, the system of IR review, feedback, and cross-verification is crucial to its success.

### 7. *Regular Maintenance*

Maintenance is crucial for all kinds of operations. Keeping up with the infrastructure, hardware, and software is important because it takes a lot of work and money to establish IR.

## **Conclusion**

Most of the Indian IRs and DLs that are listed on D-space's official website are not accessible online. Numerous links take users to the personal pages of authors, official websites, and business websites. D-space is preferred by Indian libraries over Enprints. The issue of rising journal subscription costs is becoming more and more problematic for the Learning Resource Centers, also referred to as Global Library. In a similar vein, other resource materials have grown extremely expensive and are sometimes beyond the libraries' budget. Libraries, particularly those in higher education institutions, are under increasing pressure from their patrons, and as a result, they must adapt to meet their users' comprehensive and enhanced information needs. However, new fields of interest are also emerging, and libraries must meet these evolving information demands as well. The libraries must therefore take into account a range of potential options. In this regard, the IR system has shown itself to be a practical tool for addressing the issues of rising expenses and satisfying user demands. Indian initiatives have demonstrated that there are few obstacles to implementing IR in higher education institutions. The previously discussed lessons have been learned and could be helpful to others. Open-source projects such as D-space and Enprints support digitization, digital preservation, and open access. Globally, creating and managing digital repositories has emerged as a new responsibility for library professionals.

Multiple OSS are available, which accelerates this trend. However, it appears that the extensive libraries and information centers in India are not adopting this global practice. Future studies might concentrate on the elements that lead to Indian institutions' DL/IR systems maintenance issues.

## References

- [1] Breeding, M. (2009), "The viability of open-source ILS", *Bulletin of the American Society for Information Science and Technology*, Vol. 35 No. 2, pp. 20-25.
- [2] De, R. (2009), "Economic impact of free and open-source software: a study in India", available at: [https://icfoss.in/doc/ICFOSS\\_economic-impact-free\(v3\).pdf](https://icfoss.in/doc/ICFOSS_economic-impact-free(v3).pdf)
- [3] Fernandez, Leila (2006), *Open Access Initiative in India: An Evaluation. Partnership: The Canadian Journal of Library & Information Practice and Research* Volume 1 No. 1
- [4] Fitzgerald, B. (2006), "The transformation of open-source software", *MIS Quarterly*, Vol. 30 No. 3, pp. 587-598.
- [5] Ghose SB and Das, A K(2006), *Open Access and Institutional Repository- a developing country perspective: A case study of India*, IFLA 157
- [6] Ghosh, R.A. (2007), "Economic impact of open-source software on innovation and the competitiveness of the information and communication technologies (ICT) sector in the EU", available at: <http://ec.europa.eu/enterprise/ict/policy/doc/2006-11-20-flossimpact.pdf> (access ed 10 June 2013).
- [7] Gibbons, S. (2004), *Benefits of an Institutional Repository*, *Library Technology Reports* Volume 40 No 4, p 11-16.
- [8] Krishnamurthy, M. (2008), "Open access, open source, and digital libraries: a current trend in university libraries around the world", *Program: Electronic Library and Information Systems*, Vol. 42 No. 1, pp. 48-55.
- [9] Lynch, C A (2003), *Institutional Repositories: Essential Infrastructure for Scholarship in the Digital Age. Portal: Library and the Academic* 3, No.3 327-336
- [10] Mark, W (2004), *Institutional Repositories and scholarly publishing*. Learned Publishing, Vol. 17 No. 2. Available on <http://www.uwrf.edu/library/minds/wareArtilce.pdf>
- [11] Marsan, J., Paré, G. and Beaudry, A. (2012), "Adoption of open-source software in organizations: a socio-cognitive perspective", *The Journal of Strategic Information Systems*, Vol. 21 No. 4, pp. 257-273.
- [12] Mittal, R. and Mahesh, G. (2008), "Digital libraries and repositories in India: an evaluative study", *Program: Electronic Library and Information Systems*, Vol. 42 No. 3, pp. 286-302.
- [13] Mutula, S. and Kalaote, T. (2010), "Open source software deployment in the public sector: a review of Botswana and South Africa", *Library Hi Tech*, Vol. 28 No. 1, pp. 63-80. <https://doi.org/10.1108/07378831011026698>
- [14] Nagy, D., Yassin, A.M. and Bhattacharjee, A. (2010), "Organizational adoption of open-source software: barriers and remedies", *Communications of the ACM*, Vol. 53 No. 3, pp. 148-151.
- [15] Nixon, W J. (2003), *DAEDALUS: Freeing Scholarly Communication at the University of Glasgow*. Ariadne No. 34. Available on <http://www.ariadne.ac.uk/issue34/nixon>
- [16] Prosser, D (2003), *Institutional Repositories and Open Access: The future of scholarly communication*
- [17] Sawant, S. (2011), "IR system and features: study of Indian scenario", *Library Hi Tech*, Vol. 29 No. 1, pp. 161-172.



# The Emergence of Information Civilization: The Role of Universities, Information Elites, and Consortia in Knowledge Sharing

Vineeta Chauhan

In-charge Library, SKNAU, Jobner, Rajasthan, India

E-mail: incharge.libskncoa@sknau.ac.in

## Abstract

*The human race is on the brink of a transformative shift into the information civilization, succeeding the agricultural and industrial eras that have shaped our social structures. At the core of this evolution lies microelectronics technology, particularly in the form of computers, serving as the linchpin for the development of an information society. Research universities play a pivotal role akin to steel factories in industrial societies, being the birthplace of technological innovations essential to this new era. In the information civilization, the production of information is a highly esteemed commodity, elevating those who generate it to the status of super elites. Access to this superior class is determined by merit, education, and the acquisition of knowledge through various sources and retrieval agencies. The advent of communication technology has given rise to information seekers, marking a shift towards individualized and demystified societies, where each person seeks specific information tailored to their needs. Modern communication technologies are designed to embody interactivity, demassification, and synchronicity, liberating individuals from the influence of mass media. The nature of sharing has evolved over the years, with resource sharing now encompassing computing resources rather than traditional bibliographic materials like books and journals. Many Indian university and college libraries face challenges in subscribing to all necessary journals and databases due to management support and financial constraints. To address these limitations, libraries are forming consortia, collaborative partnerships aimed at facilitating knowledge sharing at a more affordable rate. Consortia development emerges as a response to the growing desire for resource sharing, enabling institutions to pool their resources and overcome financial barriers. This paper explores the dynamics of information civilization, the role of universities, the significance of information elites, and the evolution of resource sharing through consortia, shedding light on the transformative journey towards a knowledge-centric society.*

**Keywords:** Emergence of Information, civilization, Modern communication technologies.

## Introduction

In the rapidly evolving landscape of academic libraries, electronic resources have become integral and ever-expanding components of their offerings. In navigating this dynamic environment, libraries are confronted with the dual challenge of not only delivering customer-responsive services but also adapting to constant change. The focus is shifting from mere ownership of tangible print resources to facilitating access to a plethora of electronic resources available on a large scale. The emergence of electronic resources is fundamentally reshaping the dynamics among publishers, authors, librarians, and readers, introducing implications such as cost considerations, promotional activities, and management challenges.

Libraries, tasked with the perennial responsibilities of collection development, preservation, and information retrieval, face heightened complexity with the integration of electronic resources. In countries like India, concerted efforts are underway to disseminate information embedded in electronic resources, recognized as swift sources of knowledge.

Amidst these transformative shifts, the consortia approach has emerged as a pivotal strategy for libraries aiming to harness electronic resources effectively. According to Allen Kent, the success and survival of libraries hinge on the extent to which they cooperate with each other. The development of library consortia or buying clubs is rooted in the history of cooperative library efforts. These consortia, defined as groups of organizations working collaboratively to achieve common objectives requiring cooperation and resource sharing, represent a significant departure from traditional collection development and management methods.

In the current landscape of e-consortia, libraries unite to collectively procure e-information, reflecting the changing philosophies and techniques of collection development. The rising costs of information are mitigated by e-consortia acting as agents negotiating lower purchase prices for electronic resources on behalf of all member libraries. A coordinating entity handles the identification of libraries for each publisher, negotiations, legal matters, and other operational aspects. This approach is hailed as an ideal solution if established and managed for the broader interests of society.

Publishers, recognizing the popularity of consortium subscriptions, are adapting pricing models tailored to regional, local, or national consortia. The evaluation of consortia for collective subscription to electronic resources has revolutionized information delivery in academic libraries, offering a practical solution amid escalating costs. A consortium, by sharing subscription costs among multiple member libraries, provides cost-effective licensed access to remote users. The collective strength of larger memberships enhances negotiation power with electronic publishers, resulting in favorable pricing and expanded title access. This paradigm shift in information management is influencing the activities and operations of libraries and information centers, marking a transformative phase in how information is accessed and shared.

### **The Role and Necessity of E-Journal Consortia**

In the evolving landscape of modern libraries, the need for collaboration and strategic partnerships has become increasingly evident. One prominent initiative in this regard is the formation of e-journal consortia, which facilitates unified access to a wealth of electronic resources for patrons across member libraries. The exponential increase in both print and electronic documents poses a formidable challenge for libraries in managing and providing seamless access to an expanding repository of knowledge. Libraries, recognizing the need for collaborative solutions, have historically employed various initiatives, including library networks, interlibrary loan (ILL) services, document delivery services, and the formation of library consortia. India has witnessed the establishment of significant consortia such as FORSA, CSIR Consortium, Indian Institute of Management Consortium, UGC, and INFLIBNET, each contributing to the cooperative sharing of resources.

### **Key Issues Leading to the Formation of E-Journal Consortia**

1. *Licensing Challenges:* Libraries encounter complexities related to licensing agreements, necessitating a unified approach to negotiate terms and conditions for accessing electronic journals.
2. *Technological Development:* Consortia serves as catalysts for technological advancements, creating a unified web-enabled window system that ensures a user-oriented experience for patrons while simplifying processes such as patron identification and authentication.
3. *Facilitating Research:* E-journal consortia play a pivotal role in making research more accessible and streamlined for scholars. The unified platform enhances resource discovery, aiding researchers in writing papers, and projects, conducting research work, and participating in seminars.

4. *Addressing Information Explosion*: The exponential growth of information necessitates collaborative efforts to manage, organize, and provide access to a diverse range of scholarly content available in electronic form.
5. *Meeting Diverse User Needs*: Consortia acknowledge the diverse needs of users and aim to create a comprehensive platform that caters to the varied requirements of researchers, academicians, and students.
6. *Overcoming Financial Constraints*: Libraries, often constrained by financial limitations, find strength in numbers within consortia. Collective negotiations for licensing agreements lead to cost-effective solutions, mitigating the financial burden on individual institutions.

### **Objectives of Consortia**

1. *Resource Sharing*: The fundamental purpose of consortia is to facilitate the sharing of resources, encompassing not only electronic content but also financial resources and manpower. This collaborative approach ensures that member institutions collectively benefit from a broader range of resources.
2. *Cost Efficiency*: Consortia aim to achieve substantial cost savings through joint subscriptions to electronic resources. By pooling financial resources, member institutions can access a more extensive collection of electronic materials at a significantly lower cost than if each institution were to subscribe individually.
3. *Building Digital Libraries*: Consortia play a crucial role in the development of digital libraries. By leveraging collective expertise and resources, member institutions can collaboratively build comprehensive digital repositories that enhance accessibility and provide a wealth of electronic resources to their respective user communities.
4. *Cost Sharing for Technical and Training Support*: Consortia facilitate cost-effective technical and training support by sharing resources and expertise in these areas. This collaborative effort ensures that member institutions can benefit from shared knowledge and resources, optimizing technical infrastructure and training programs.
5. *Prevention of Duplication*: One of the key objectives is to avoid duplication of subscriptions to electronic resources. A consortium enables member institutions to coordinate their resource acquisition efforts, ensuring that subscriptions are optimized to meet the diverse needs of their user communities without unnecessary redundancy.
6. *Promotion of National Funding Views*: Consortia works towards aligning with national perspectives on fund allocation for electronic resources. By coordinating subscription efforts at a national level, consortia contribute to a cohesive and strategic approach to funding, supporting the overall advancement of academic and research objectives at a broader scale.
7. *Enhanced Information Access*: Consortia aim to promote a better, faster, and more cost-effective means of providing electronic information resources to users. By leveraging collective bargaining power, consortia negotiate favorable terms with publishers and vendors, resulting in improved access to a variety of electronic resources for member institutions.

In summary, the objectives of consortia revolve around collaborative resource sharing, cost efficiency, digital library development, technical and training support, prevention of duplication, alignment with national funding views, and the enhancement of information access for the benefit of member institutions and their user communities.

## **Development of Consortia**

The term 'consortium' signifies a temporary collaboration of various powers or large interests to achieve a common purpose. In the realm of libraries, a consortium is defined as a community or cooperative comprising two or more information agencies formally agreeing to coordinate, cooperate, or consolidate certain functions to attain mutual objectives.

More specifically, it is a group of libraries that unite to pool their resources, granting users access to the combined resources through inter-library loan or borrowing privileges. A library consortium, in essence, represents a community of value-creating entities that generate value through an aggregation of library units within and across organizations, enhancing value creation via resource-sharing processes, products, and services.

The evolution of library consortia traces back to instances where multiple libraries voluntarily joined forces for the mutual benefit of their users, akin to cooperative initiatives. This marked the initial stage of library cooperation. The second stage witnessed the advent of computerized networks facilitating resource sharing. During this period, library resources were predominantly in traditional printed formats, and networks established bibliographical databases. Users from participating libraries could access required documents from others through document delivery services.

With the emergence of electronic resources (e-resources), the concept of consortia gained prominence, primarily for the acquisition of e-journals. The term, originally used in commercial and political contexts, has been imported into the library domain. As the resources procured through consortia today are predominantly e-resources, users can access and download required materials remotely without the need for elaborate inter-library lending processes.

While library consortia initially focused on a narrow purpose, particularly the acquisition of e-resources, they have the potential to evolve into efficient instruments for sharing various types of library resources. This evolution reflects the adaptability of consortia in meeting the changing needs of libraries and users, transforming from cooperative initiatives in the print era to dynamic entities facilitating comprehensive resource sharing in the digital age.

## **Types of Consortia**

Library consortia operate under various organizational models, adapting to the diverse needs and characteristics of participating institutions. Over the past three decades, consortia have evolved into different types of structures, ranging from loosely affiliated buying clubs to tightly integrated organizations with long-term commitments and collaborative decision-making. Theoretically, consortia can be categorized based on their characteristics:

### **Types of Libraries Forming the Consortium**

1. *Consortia of Multi-type Libraries*: Participating libraries are of different types, such as public, academic, and special libraries.
2. *Consortia of the Same Type of Libraries*: Members of the consortium are of the same type, for example, a consortium of public libraries, academic libraries, etc. (e.g., CSIR E-Journals Consortium).

### **Geographical Region of Coverage Consortium**

1. *Local Level Consortia*: Consists of libraries in a specific city, town, or district.
2. *State-Level Consortia*: Includes libraries from a particular state.

3. *National Level Consortia*: Encompasses libraries belonging to a country (e.g., INDEST, focusing on scientific and technical institutions).
4. *Regional Level Consortia*: Involves libraries from a specific region.
5. *International Level Consortia*: Comprises libraries from different countries, forming either individual libraries or federations of national consortia (e.g., International Coalition of Library Consortia).

#### **Subject or Area of Coverage Consortium**

1. *Single Discipline Oriented Consortia*: Organizations dealing with the same or similar disciplines join together (e.g., FORSA - Forum for Resource Sharing in Astronomy and Astrophysics).
2. *Multi-discipline Oriented Consortia*: Encompasses resources in multiple disciplines (e.g., UGC-sponsored INFONET, covering multiple subjects).

#### **Organizational Point of View Consortium**

1. *Loosely Knit Federation*: Lacks a central body with dedicated staff, often formed for immediate gains and may not be permanent.
2. *Tightly Knit Organization*: A permanent type of consortium with a central body guiding activities and dedicated staff for consortium operations.

#### **Basis of Formation Consortium**

1. *Non-Sponsored Consortia*: Formed voluntarily by participating libraries, with expenses shared among members (e.g., FORSA).
2. *Sponsored Consortia*: Sponsored by a central organization, major expenses are borne by the sponsor, and sometimes the sponsor itself conducts major consortium activities (e.g., UGC-INFONET).

It's important to note that these categories are not mutually exclusive, and many consortia exhibit characteristics from multiple categories, reflecting the diverse and adaptable nature of these collaborative initiatives.

#### **Consortia in India**

Consortia have become an integral part of the library landscape in India, driven by the ubiquity of digital information published worldwide through the Internet. The cooperative, coordinated, and collaborative efforts among libraries for sharing information resources have seen significant growth since the 1980s, spurred by advancements in Information and Communication Technology. Some major consortia in India include:

##### *1. INDEST*

Initiated by the Ministry of Human Resource Development (MHRD) in 2003, the Indian National Digital Library in Engineering Science and Technology (INDEST) Consortium focuses on providing funds for access to electronic resources to core members, including IITs, NITs, IISc, IIMs, and others. It subscribes to over 4000 e-journals, making it one of the most ambitious initiatives in India.

##### *2. UGC-INFONET*

Launched in December 2003, the UGC-INFONET Digital Library Consortium is a collaborative effort by UGC, INFLIBNET, and ERNET. It aims to provide scholarly e-journals to Indian academics and modernize university campuses through state-of-the-art campus-wide networks.

### 3. Consortium for e-Resources in Agriculture (CeRA)

Established under the National Agricultural Innovation Programme (NAIP), CeRA provides access to 2000+ journals from various publishers, covering six major subject fields. It was created to develop the R&D information resource base of ICAR institutions and promote an e-access culture among scientists and teachers.

### 4. CSIR Consortia

The Consortium for CSIR Laboratories for Accessing E-journals, initiated by the National Institute of Science Communication and Information Resources (NISCAIR), is collaboration among various CSIR laboratories. It facilitates pooling, sharing, and electronic access to library resources, aiming to provide access to 4500 world-class e-journals.

### 5. FORSA Libraries Consortia

The Forum for Resource Sharing in Astronomy and Astrophysics (FORSA) was established in 1981, comprising institutions like the Indian Institute of Astrophysics and the Inter-University Centre for Astronomy and Astrophysics. It focuses on sharing resources in areas common to R&D activities in astronomy and astrophysics.

### 6. HELINET

The Health Sciences Library and Information Science Network Consortium (HELINET) were formed in 2001 under the Rajiv Gandhi University of Health Sciences. It networks libraries to minimize the cost of acquiring learning resources for medical colleges. HELINET provides access to about 600 scholarly international biomedical journals from leading publishers.

These consortia represent collaborative efforts to enhance resource access, reduce costs, and foster knowledge sharing in diverse academic and research domains across India.

## Consortia in other Countries

Though there are hundreds of consortia in other countries, we shall briefly discuss a few of them, which are mentioned below, in this section:

1. IDAL
2. KERIS
3. CONCERT
4. CURL
5. ICOLC

## Advantages of Consortia

1. *Enhanced Library Services*: Consortia facilitate the provision of better library services, including services like the Current Awareness Service (CAS) and Selective Dissemination of Information (SDI).
2. *Space and Cost Efficiency*: Electronic journals do not require physical library space, shelving costs, and are not susceptible to theft, contributing to space and cost efficiency.
3. *24/7 Accessibility*: Electronic resources, including journals, are available 24 hours a day, 7 days a week, providing users with continuous access.
4. *Storage of Resources*: Digital resources can be stored efficiently without the need for physical storage space, contributing to the preservation and accessibility of information.
5. *Sharing Staff Expertise*: Consortia allows for the sharing of staff expertise among member institutions, fostering collaboration and knowledge exchange.
6. *Union List of Serials*: Consortia often maintain a union list of serials, facilitating efficient resource sharing and acquisition.

7. *Financial Benefits*: Participating in consortia can result in financial benefits, as pooled resources and collaborative negotiations with publishers may lead to reduced subscription costs.

### **Disadvantages of Consortia**

1. *Absence of Printed Copies*: One disadvantage is the absence of printed copies of journals, which may be a preference for some users or institutions.
2. *Lack of Archiving and Back Files*: Some consortia may face challenges in archiving and providing access to back files of electronic resources.
3. *Copyright Issues*: Copyright problems may arise, affecting the ability to share and distribute electronic content freely.
4. *Internet Access ID Required*: Users may need specific Internet access credentials to utilize electronic resources within the consortia.
5. *High Initial Investment*: Consortia often requires a high initial investment in licenses and information and communication technology, which can be a challenge for some institutions.

### **Conclusion**

While consortia offer numerous advantages, including cost savings, enhanced services, and efficient resource sharing, they also face challenges such as the absence of printed copies, copyright issues, and the need for significant initial investment. As the digital landscape evolves, efforts should be made to address these challenges, especially in the areas of archiving and digital preservation. Libraries in India, through initiatives like INDEST and INFLIBNET Consortium, should consider exploring options for digital preservation to ensure long-term accessibility of e-resources and safeguard digital scholarship for future generations. Exploring various preservation models, including international initiatives like Portico, LOCKSS, and CLOCKSS, can contribute to the long-term sustainability of digital content.

### **References**

- [1] Baldev Kumar (2014). Library consortia: advantages and disadvantages. International journal of librarianship and administration. Vol. 5(2), 125-129p.
- [2] Birdie, Christina and Alladi, Vagiswari (2002). The future of consortia among Indian libraries- FORSA consortium as a forerunner? Library and information services in astronomy IV, 165-171p.
- [3] CeRA-Consortium. Retrieved November 14, 2023. From <http://cera.jccc.in/about/aboutCeRA.pdf>
- [4] Chauhan, Suresh K., & Prem Chand. (2007). UGC-Infonet: E-Journals Consortium and Indian Academics: The Right Initiative at the Right Time. Library Philosophy and Practice Retrieved September 3, 2023 from <http://www.webpages.uidaho.edu/~mbolin/chauhan.htm7>.
- [5] Francis, A.T. (2005). Library Consortia Model for Country-Wide Access of Electronic Journals and Databases. Retrieved Jan 6, 2012 from <http://eprints.rclis.org/archive/00004915/02/consortia.pdf8>.
- [6] Gaur R C and Tripathi M, Digital preservation of electronic resources, DESIDOC Journal of Library & Information Technology, Special issue on Digital Preservation, 32 (4) (201).
- [7] Ghosh, M. (2002). Indian Academic Library Consortia (IALC): A proposal for electronic resource sharing. Retrieved Dec 25, 2011 from [http://eprints.rclis.org/archive/0000\\_7292/01/CRIMEA\\_2002.pdf](http://eprints.rclis.org/archive/0000_7292/01/CRIMEA_2002.pdf).
- [8] Ghosh, Maitrayee, Biswas, S.C., & Jeevan, V.K.J. (2006). Strategic cooperation and consortia building for Indian libraries: models and methods. Library Review, 55(9), 608-620.
- [9] <http://delcon.gov.in/about.php>
- [10] <http://nlist.inflibnet.ac.in/eresources.php/>

- [11] <http://paniit.iitd.ac.in/indest/index.php/>
- [12] <http://www.ermed.in/>
- [13] <http://www.inflibnet.ac.in/ess/eresources.php/>
- [14] Jayaprakash (A) and Yogeshwar Rao (M). Consortia-based resource sharing among libraries and information centers in the digital era. National Conference on Information Management in Digital Libraries, Kharagpur, 2006. Proceedings.
- [15] Kent, Allen. (1978). Encyclopedia of Library and Information Science. New York: Dekker.
- [16] Kumar (T S). Library consortia: a conceptual overview. <http://www.alibnet.org/Dr.T.S.Kumbhar.pdf> (visited on 16.3.2022).
- [17] Kumbar, M.F. 2004). Consortia for Management College Libraries in the E-Publishing Era: A Proposal. Retrieved Dec 3, 2017, from <http://eprints.rclis.org/archive/00003978/01/consortia.Pdf>.
- [18] Kushwaha, S. S., Jambhekar, A. & Gautam, J. N. (2003, February). Consortia initiative for access to electronic publications in Indian Libraries. Retrieved November 28, 2006, from [http://dspace.inflibnet.ac.in/bitstream/1944/200/3/03cali\\_31.pdf](http://dspace.inflibnet.ac.in/bitstream/1944/200/3/03cali_31.pdf).
- [19] Lobo, Janet Dotty & Bhandi, M.K. (2007). E-resources in the digital era: Special reference to health sciences library and information network consortium: Helinet. SRELS Journal of Information Management, 44(1), 63-66.
- [20] Murthy (T A V). Resource sharing and consortia for India. Information management in e-libraries. National Conference on Information Management in E-libraries, Kharagpur, 2002. Proceedings. p. 14-15.
- [21] Muthu, M (2013). Resource sharing in libraries: A vital role of consortia. International research journal of library & information science. Vol. 3 (1).
- [22] Narasimhan (G N). Resource sharing focuses on history ILL and document delivery, cooperative collection development – assumptions, problems, and solutions. National Conference on Information Management in E-libraries, Kharagpur, 2002. Proceedings. p. 556-564.
- [23] Pandian, M.P. and Karisiddappa, C.R. (2003). Technology Issues for Library C Consortia in India. Retrieved Dec 30, 2011, from <http://shodhganga.inflibnet.ac.in/dxml/handle/1944/204>.
- [24] Patil, Y.M. and Savanur, K.P. 2006). Consortium Approach to E-Resource Sharing – A Case Study. Retrieved Dec 3, 2017, from [http://eprints.rclis.org/archive/00009070/01/AFITA\(Preprint\).pdf](http://eprints.rclis.org/archive/00009070/01/AFITA(Preprint).pdf)
- [25] Shachaf (Penina). Nationwide library consortia lifecycle. Libri. 53; 2003; 94-102.



# A Study on the Use of Digital Libraries by Engineering Students: A Case Study

S. Rajasekaran<sup>1</sup>, Dr. M. Mani<sup>2</sup> and Dr. C. Pandeewaran<sup>3</sup>

<sup>1</sup>Assistant Librarian, <sup>2&3</sup>Librarian,

<sup>1&2</sup>Builders Engineering College, Kangeyam, Tamil Nadu, India

<sup>3</sup>Kangeyam Institute of Commerce, Kangeyam, Tamil Nadu, India

E-mail: rajakoki07@gmail.com

## Abstract

*The central library of Builders Engineering College (BEC) Kangeyam, Tamil Nadu has a Digital library section, where the students access to e- resources for their academic work. The digital library section provides access to a number of e-resources. To explore its use, data was collected through a questionnaire. A total of 180 copies were distributed, with 485 fully completed response. The response was compiled, and the results show that the students utilized digital library resources for purposes such as collecting information, preparing for competitive exams, completing project, assignment and engaging in research related activities.*

**Keywords:** Digital library, E- Resources, Use by Engineering students, Case study.

## Introduction

Technological revolution in electronics field has facilitated the emergence of digital technology, leading to the development of numerous modern Information Communication Technology (ICT) that offer significant benefits to human society. Digital technology has penetrated various dimensions and forms, making a notable impact on nearly every aspect of human life. ICT allows for swift access to and efficient storage of information, promoting improved communication, collaboration, and information sharing. Its influence spans diverse fields, encompassing flexible manufacturing processes, image enhancement systems, and word processing, thereby supplanting traditional print-based repositories of information.

## Objectives of the Study

1. Conducting an exploration of the engineering college students' engagement with the library.
2. To assess the nature of use of digital library resources
3. Evaluating the level of satisfaction regarding the library's collection and services among the student
4. Identifying the extent of computer and online service utilization within the library environment.

## Methodology

The stratified simple sampling method was selected as the most appropriate means to accurately depict the influence of information and communication technology on the user utilization within the realm of builders engineering at Kangeyam. A total of 180 copies of questionnaire were distributed to students of various disciplines within the college. Of these, 154 responded. Twenty-six responses were excluded from consideration due to lack completeness. The analysis focused on all the 154 responses for the current study.

## Data Analysis and Interpretation

Table I Majority of respondents Artificial Intelligence & Data Science students account for the majority of respondents at 19%. Followed by Electrical Communication Engineering and Electrical and Electronics Engineering response at 18%, Computer Science Engineering response at 16%, Civil Engineering response at 15%, and Mechanical Engineering response at 14%.

TABLE I DISTRIBUTION OF RESPONDENTS BY DEPARTMENT WISE

S.No.	Department	Response	Percentage
1	ECE	28	18
2	CSE	25	16
3	EEE	27	18
4	CIVIL	23	15
5	MECH	22	14
6	AI&DS	29	19
Total		154	100

Source: Primary Data

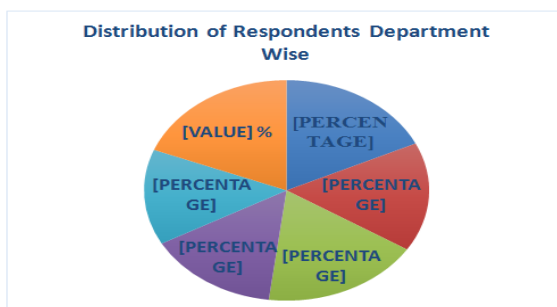

Fig.1 Distribution of Respondents by Department Wise

TABLE II GENDER

S. No.	Gender	Respondents	Percentage
1	Male	90	58
2	Female	64	42
TOTAL		154	100

Source: Primary Data

Table II described the distribution of respondents by Gender wise. Majority of respondents 90 (58%) belongs to male category whereas 64 (42%) of the respondents belong to female category.

TABLE III TIME SPENT IN DIGITAL LIBRARY

S.No.	Hours	No. of Respondents	Percentage	
1	1-2 Hours	36	23	23
2	2-3 Hours	32	21	44
3	3-4 Hours	47	31	75
4	4-5 Hours	14	9	84
5	More Than 7 Hours	25	16	<b>100</b>
Total		154	100	

Source: Primary Data/Record of the library

Table III illustrate the demographic distribution of respondents based on the Number of hours spend of digital library resource utilized. The majority of respondents primarily use 3-4 hours, accounting for 31%, followed by 1-2 hours at 23%, 2-3 hours at 21%, representative 4-5 hours at 9%, and more than 7 hours at 16%.

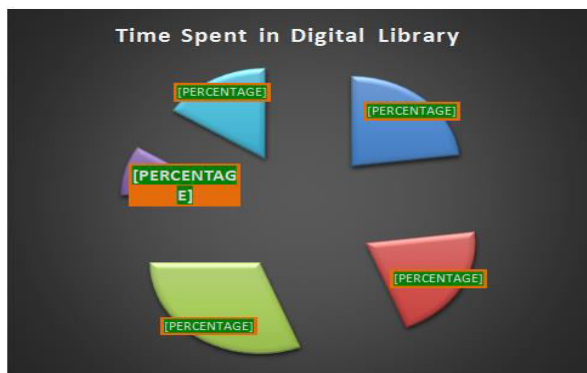

Fig.3 Time Spent in Digital Library

TABLE IV FREQUENCY OF DIGITAL LIBRARY USE

S.No.	Frequency Users	Response	Percentage
1	Daily	60	39
2	Three to Four days in a Week	32	21
3	Weekly	20	13
4	Less than 5 days in a month	23	15
5	Above 8- 10 in a Monthly	19	12

Source: Primary Data

Table IV Illustrate the demographic distribution of respondents based on the type of digital library resource utilized. The majority of respondents primarily use daily, accounting for 39%, followed by three to four days in a week at 21%, Weekly at 13%, less than 5 days in a month at 15%, and above 8-10 in a Monthly 12%.

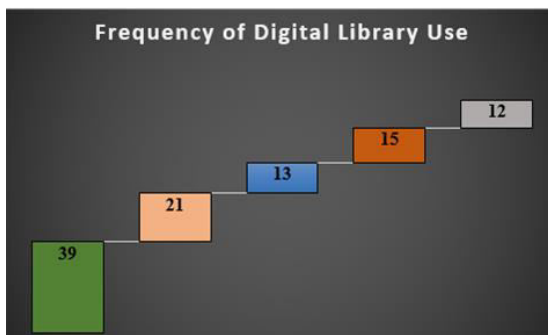

Fig.4 Frequency of Digital Library Use

TABLE V UTILIZATION OF TYPE OF DIGITAL LIBRARY PLATFORMS

S.No.	Resources	Response	Percentage
1	E-Books	55	36
2	E- Periodical	32	21
3	E- Newspaper	19	12
4	E-Project	25	16
5	E- Question	23	15
Total		154	100

Source: Primary Data

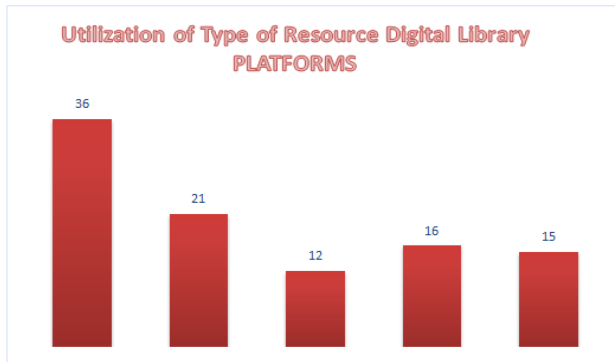

Fig. 5 Utilization of Type of digital platforms

It is observed from the table V that the majority of respondent e-books at 55(36%), followed by e-periodical respondent at 32 (21%), e-newspaper respondent at 19(12%), e-project respondent at 25(16%) and e- question respondent at 23(15%).

TABLE VI EFFECTIVENESS OF DIGITAL LIBRARY

S.No.	Options	No of Responses	Percentage
1	Yes	120	78
2	No	34	22
Total		154	100

Source: Primary Data

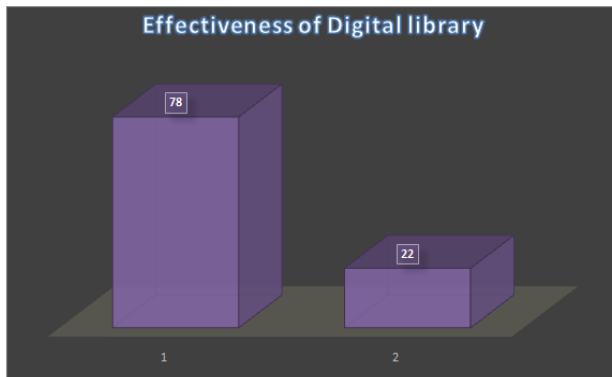

Fig. 6 Effectiveness of Digital library

Table VI and fig.6 indicate that a majority of Students 120 (78%) found digital library very useful.

TABLE VII IMPACT OF DIGITAL LIBRARY SERVICES

S.No.	Impact of Digital Library services	Response	Percentage
1	Comfortable and Quick Access	65	42
2	Access to Current Information	55	36
3	Wide Range of Information	34	22
Total		154	100

Source: Primary Data

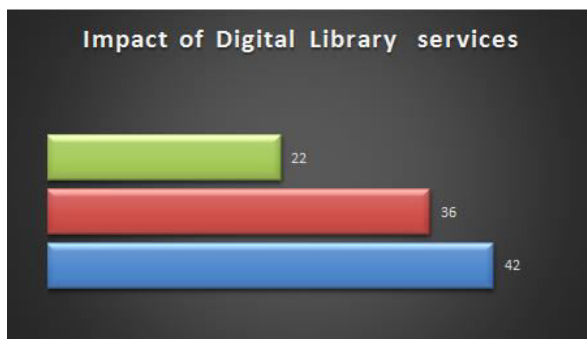

Fig. 7 Impact of Digital Library services

Table VII and fig.7 illustrate the demographic makeup of impact on student's majority of student, 65(42%) enabled quick access, followed by Access to Current Information at 55(36%) and wide range of information 34(22%).

### Findings

1. 19% of the respondents of Artificial Intelligence & Data Science.
2. 58% of the respondents are male.
3. 31% of the respondents belong to the category of 3-4 hours.
4. 36% of the respondents belong to e-books.
5. 78% of the respondents effectiveness of digital library yes.
6. 42% of the respondents form comfortable and quick Access purpose.

### Suggestions

The digital library appears to be quite popular among the student's community. To maintain and increase the use, the digital library systems and platforms may be periodically reviewed and expanded upgraded.

### Conclusion

The findings of this study highlight a notable awareness among students regarding e-resources. It is found that e- books are the most widely used e- resource. There is various digital library resources like e- books, e- journals etc. are well utilized by the student's community.

### References

- [1] B. Dhanalakshmi use and impact of library services on users: a case study of aurora engineering college, bhongir. *International Journal of Digital Library Services* ISSN: 2250-1142 (Online), ISSN 2349-302X Vol. 7, April - June, 2017, Issue - 2.
- [2] Mani M & Pandeewaran C Use pattern on Electronics information Resources by the students of Theni Kammavar Sangam College of arts and science, Theni, Tamil Nadu: A case study. *Multidisciplinary Approaches in Web and Open Education Resources Opportunities & Challenges (MAWOER -2023)* ISBN No: 978-93-94503-19-9.
- [3] Rajasekaran S & Pandeewaran C, Selvakamal P, Ganesamoorthy. M, Digital Library Services and its Utilization among the Students: A Case Study. *Journal of Information Technology and Sciencese-ISSN: 2581-849X* Volume-9, Issue-1 (January-April, 2023).
- [4] S. Rajasekaran & M. Ganesamoorthy, P. Selvakamal, M. Mohan Services Provided by Academic Libraries in the Modern Era. *Journal of Information Technology and Sciencese-ISSN: 2581-849X* Volume-9, Issue-1 (January-April, 2023)

- [5] Ramakrishna. K & Prof. Sasikala C. Gowridevi R. Availability and *Usage of Library and Information Resources and Services at K L University, Vijayawada, Andhra Pradesh, India.*
- [6] Shivakumaraswamy, K. N. (2019). *Use of Web-Based Library Services in Mysore City Engineering Colleges in Karnataka, India: A Study.* Library Philosophy and Practice (e-journal), 2370.
- [7] Sridhar, M, S. (1995), Understanding the User - Why, What and How? Library Science with a slant to Documentation and Information Studies, 32(4), 151-164.
- [8] Varadaraju. (2018). *Use of Library Resources and Services at Stanley College of Engineering and Technology for Women, Hyderabad: A Case Study NCH.* Indian Journal of Information Sources and Services, 8(1), 46-53.

# Navigating the Digital Landscape: A Study on the Effectiveness of E-Resources

T. S. Somashekhar<sup>1</sup>, S. Shamala<sup>2</sup> and Dr. Vitthal Bagalkoti<sup>3</sup>

<sup>1&2</sup>Research Scholar, <sup>3</sup>Assistant Professor & Library Officer,

<sup>1,2&3</sup>CMR University, Bangalore, Karnataka, India

E-mail: Somashekhar.ts@cmer.edu.in

## Abstract

*This article delves into the diverse dimensions of electronic resources and assesses their efficacy within academic libraries. The advent of digital technology has significantly expedited and simplified the application of accumulated knowledge. This wealth of information, amassed over the years, becomes imperative for future research, societal transformation, and overall progress. Electronic resources offer solutions to storage challenges and facilitate the efficient flow of knowledge, making digitized print and electronic repositories increasingly vital for academic institutions. The integration of technology has prompted libraries to introduce new elements into their catalogs, with e-resources emerging as the most prominent addition. This document outlines the necessity of e-resources, elucidates their advantages, assesses the effectiveness of their utilization, explores various kinds of e-resources and their services, and concludes with an overview that discusses both the merits and demerits of these valuable assets.*

**Keywords:** E-Resources, Academic Libraries, Knowledge Management, Digitized print

## Introduction

Libraries, spanning public, research, academic, and special categories, have consistently shown interest in adopting the latest technologies to enhance services and improve operational efficiency. The contemporary focus is on implementing emerging technologies, particularly electronic resources (e-resources), which offer the possibility of reducing expenses and improved management of collections and patron services. E-resources encompass electronically accessible information, available through devices such as computers, laptops, mobile devices, and tablets, either locally, globally via the internet (Johnson *et al.*, 2012).

Various forms of digital things, including e-books, e-journals, interactive items, and multimedia titles, are becoming integral for libraries adapting to the changing landscape of the 21st century. The rapid growth of e-media is transforming libraries into entities prioritizing e-services. On one hand, there's a demand for a richer library collection, while on the other, the publishing industry is challenged to keep up with this demand through swift e-publishing and online access (Venkadesan *et al.*, 2004).

Ranganathan's fifth law, stipulating that the library is a growing organism (Ranganathan, 2006), emphasizes the imperative for libraries to continually expand. Although physical space constraints may seem less urgent in the digital era, libraries grapple with challenges related to electronic information and the ongoing importance of analog content. Despite the rise of e-resources, libraries continue to manage storage issues, and the creation of new print content persists without altering the pace of expansion.

Looking ahead, Lancaster's vision of a fully digital world may not materialize in the near future. Librarians face ongoing challenges in balancing bookshelf space with electronic terminal space to meet the ever-expanding needs of users. Both the libraries and the librarianship profession are growing organizations, with the demand for expanded services requiring additional training and

expertise. The fifth law, in a marketing context, underscores the need for libraries to adapt to future consumer needs, mobilize resources, and address emerging user requirements, programs, user groups, and global shifts. Libraries must continually update their programs and embrace new technologies to stay ahead. Employee literacy in science is essential, and the efficient implementation of marketing strategies is crucial for libraries and information facilities to thrive.

### **Objectives of the Study**

1. Identify and categorize the diverse types of e-resources accessible on a global scale.
2. Systematically outline the advantages and disadvantages inherent in the utilization of e-resources.
3. To know the efficient utilization of e-resources within library settings.
4. Investigate the necessity and advantages associated with the utilization of electronic resources (e-resources).

### **Review of Literature**

A review of the literature was conducted to set the stage for the research.

Hossaini (2017) completed a study on two chosen university libraries titled "Use and Impact of Electronic Resources." Primary and secondary data collecting is discovered to be the methodology employed in this study—secondary data was gathered from earlier research projects and primary data was obtained via survey questionnaires. Another major area of interest for this research is the study of how users are affected by electronic resources. Hossaini (2017) concludes that electronic resources in intuitional libraries are increasing daily as a result. The library's traditional books are being replaced with electronic resources. It is also noticeable that using electronic resources has advantages and disadvantages.

Ananda (2017) carried out a research study titled "use and awareness of electronic information resources among UG & PG students at T John College, Bangalore: A study." According to the survey, 81% of respondents claimed to be aware of electronic information resources, while 19% claimed to be unaware of them. Project research is the main goal of students' use of electronic information services.

Mwantimwa, K; Mwabungulu, E; Kassim, M (2021) the study reveals variations in the utilization of e-resources for teaching and research across the participating universities. Open access resources play a more significant role in supporting these activities compared to subscribed resources. Challenges such as limited access to full-text articles, insufficient search skills, and slow internet speed hinder effective utilization.

Nevertheless, the study confirms the positive impact of e-resources on teaching and research. To enhance usage, the study recommends increased collaboration between librarians and academic staff through outreach and marketing initiatives.

### **Need of E-Resources**

The evolving landscape of education is transitioning from conventional learning methods to a more digitized and intelligent approach, facilitated by the use of modern electronic devices. Today's technologically adept learners engage in knowledge acquisition by accessing e-documents conveniently, irrespective of location or time, covering a wide range of subjects. This study is conducted to assess the efficacy of electronic resources in academic libraries in response to the changing preferences and practices in contemporary learning.



### **Effectiveness of E-Resources**

The 21st Century has witnessed remarkable enhancements in education due to the influence of Information Technology (IT). The traditional methods of teaching and learning are progressively transitioning towards online platforms. The introduction of digital libraries, virtual libraries, and the concept of e-libraries has become prevalent in the current educational landscape. E-information resources offer greater convenience compared to traditional information services. Electronic tools are readily available in web-enabled platforms to facilitate teaching and learning processes. Significant improvements in e-publishing have been evident in recent years, with publishers addressing issues like printing costs, fluctuating readership, uncertain user intentions, and the preservation of archiving rights.

Many users and corporate entities are committed to peer-publishing and ensuring the quality assurance of diverse scholarly publications. Researchers are keen on easily accessing full-text articles and establishing connections between references in a dynamic knowledge space. The primary objective of e-services is to provide users with accessible information to enhance their knowledge.

The Services encompass a comprehensive array of offerings, incorporating pertinent details on various aspects, including Workshops dedicated to library instruction, collections management, and multimedia tools. Notably, our specific e-services entail facilitating remote access and delivering library resources, constituting a vital component of Library Information services. In compliance with applicable laws and organizational guidelines, access privileges may be restricted to members or specific resources. This includes instances where access is channeled through commercial servers, ensuring that only authorized participants can gain entry through secure password protection mechanisms.

Libraries play a crucial role in facilitating research and study through the evaluation of electronic resources. They align their offerings with educational syllabi, maintaining a blend of traditional and innovative materials to meet the diverse needs of users. The concept of "learn anywhere and anytime" has gained prominence in recent years, emphasizing the importance of alternative information access.

In educational institutions, such as colleges and high schools, libraries cater to the needs of teachers, students, and researchers. However, the current challenge faced by users is information overload, leading to difficulty in discerning valuable references amid the "Information Explosion." To address this, an education program with clearly defined learning goals and reliable guidance is essential. Libraries are evolving to incorporate new technologies into their education and research processes, acknowledging the significance of adapting to change.

While maintaining conventional information services, libraries are increasingly incorporating elements of remote e-access. Web-OPAC (Online Public Access Catalogue) allows users to access bibliographic records from anywhere, enabling efficient searches based on keywords, topics, authors, titles, and areas. This integration enhances the overall bibliographic structure.

Furthermore, for effective management of electronic resources, institutions must establish maintenance teams to monitor hardware and software. Regular servicing is crucial to minimize issues such as system errors and viruses, ensuring smooth operation and preventing disruptions. Despite the role of ICT professionals, their availability may be limited, emphasizing the need for dedicated maintenance teams.

Exposure to digital infrastructure significantly impacts the learning and research capabilities of students. Quantitatively, an institution's research output, measured by articles, citations, inventions, research scholarships, consultancies, studies, accreditations, and recognitions, reflects its overall performance and resource impact.

### **The different types of E-Resources Available Globally**

Various types of e-resources in the academic environment include:

1. *Electronic Journals (e-Journals)*: Digitized versions of traditional print journals, accessible online.
2. *Electronic Books (e-Books)*: Digital versions of books available for online reading or download.
3. *Databases*: Collections of organized data, such as academic articles, research papers, and other scholarly materials.
4. *Electronic Theses and Dissertations (ETDs)*: Digitized versions of graduate theses and doctoral dissertations.
5. *Online Reference Materials*: Electronic versions of dictionaries, encyclopedias, and other reference works.
6. *Multimedia Resources*: Includes audio, video, and interactive content used for educational purposes.
7. *Institutional Repositories*: Digital collections of an institution's scholarly outputs, such as theses, dissertations, and research papers.
8. *Digital Archives*: Collections of historical documents, manuscripts, and records in digital format.
9. *Simulations and Virtual Laboratories*: Virtual environments for conducting experiments and simulations.

### **Types of E-Resources Services**

1. *Current Awareness Service (CAS)*: CAS is a service that keeps users informed about the latest developments, publications, or research in a specific field. It provides timely updates, ensuring users stay current with relevant information.
2. *Selective Dissemination of Information (SDI)*: SDI is a personalized information service that delivers specific content to users based on their interests, preferences, or predefined criteria. It helps users filter and receive relevant information tailored to their needs.
3. *Document Delivery Services (DDS)*: DDS involves the delivery of documents or information to users in electronic format. This service ensures that users can access the full text of articles, papers, or other materials they need for research or study purposes.
4. *Web-based Online Public Access Catalogue (WEB OPAC)*: WEB OPAC is an online catalog system that allows users to search and access library resources, including books, journals, and multimedia materials. It provides a web-based interface for users to explore the library's collection and find relevant materials.
5. *E-Document Delivery Services*: E-Document Delivery Services involve the electronic distribution of documents, such as articles, research papers, or other informational materials, to users through online platforms. These services streamline the process of accessing and delivering documents, enhancing efficiency and convenience in information retrieval.

Research and rce services play crucial roles in enhancing information access, facilitating efficient research, and ensuring that users receive personalized and relevant content in the digital environment.

### **Issues in E-Resources**

1. *Costs*: The expenses associated with acquiring and maintaining electronic resources, including licensing fees, subscription costs, and infrastructure investments, can pose financial challenges for institutions.
2. *Access and Connectivity*: Unequal access to the internet or digital devices can create disparities in the ability of users to benefit from e-resources, limiting the inclusivity of online education.
3. *Technical Challenges*: Issues such as system downtime, software glitches, or compatibility problems may hinder the seamless use of electronic resources, affecting the overall user experience.
4. *Security Concerns*: E-resources are susceptible to cybersecurity threats, including hacking, data breaches, and unauthorized access, raising concerns about the confidentiality and integrity of digital information.
5. *Digital Preservation*: Ensuring the long-term preservation and accessibility of electronic resources poses a challenge, especially as technologies evolve and formats become obsolete.
6. *Quality and Reliability*: Assessing the reliability and credibility of online information sources is crucial, as the internet is flooded with vast amounts of content of varying accuracy and authenticity.
7. *User Skills and Literacy*: Users may face challenges in navigating and effectively utilizing electronic resources if they lack the necessary digital literacy skills, hindering the potential benefits of these resources.
8. *Copyright and Licensing*: Managing copyright issues, adherence to licensing agreements, and addressing intellectual property concerns are ongoing challenges in the digital environment.
9. *Changing Formats*: The rapid evolution of technology can result in changes to file formats and software, leading to compatibility issues and the need for constant updates and adaptations.
10. *Information Overload*: The abundance of online information can lead to information overload, making it challenging for users to filter and identify relevant, high-quality content efficiently.

### **Conclusion**

Implementing e-resources signifies a departure from age-old traditions, allowing the everyday reader to access details at any time. The utilization of e-resources proves beneficial in ensuring comprehensive and focused knowledge acquisition. These resources empower users and libraries to handle various search options independently, ultimately saving library space and user time. In the contemporary era often referred to as the information age, the recognition of knowledge as a crucial tool for a nation's socio economic, cultural and political growth is growing. Electronic tools, especially in libraries and knowledge centers, play a significant role in this digital world. This can be attributed mainly to the wealth of information, the prevalence of machine-readable data, the increased usage, and concerns about storage capacity. The internet and electronic information services have become integral components of today's education system. In conclusion, the web and e-resources have fundamentally transformed the way individuals connect, interact, access, receive, scrutinize, and engage in the creation and reuse of content. These transformations prompt groundbreaking shifts across almost every facet of the contemporary educational and learning landscape.

## References

- [1] Ananda S. K, A., Tejashwini B, T., Akshatha A. K and Jagdeesh G. E, J. (2017). Use and Awareness of Electronic Information Resources among UG & PG Students of T John College, Bangalore: A Study. *International Journal of Library and Information Studies*, 7(1).
- [2] Habiba, U., & Ahmed, S. Z. (2020). Demographics and perceived computer skill levels as predictors of faculty awareness and use of electronic information resources. *Digital Library Perspectives*. 36(3), 281-301.
- [3] Hossaini, S. (2017). Use and Impact of Electronic Resources: A Study on Two Selected Academic Libraries. *International Journal of Law, Humanities & Social Science*, 1(1), 23-59.
- [4] Johnson, E. (2012). Internet resources for the anaesthesiologist. *Indian Journal of Anaesthesia*, 56(3), p.219.
- [5] Mwantimwa, K., Mwabungulu, E., & Kassim, M. (2021). Academic Staff and Researchers' Use of Electronic Resources in Tanzania: A Comparative Study. *International Journal of Education and Development Using Information and Communication Technology*, 17(2), 55–75.
- [6] Parthasarathy R, and Kavitha, S. (2014). Impact of Electronic Resources on Academic Program in arts and science colleges Tiruchirappalli A study. *Shodhganga*
- [7] Ranganathan, S., Sivaswamy Aiyer, P. and Sayers, W. (2006). *The Five Laws of Library Science*. New Delhi: Ess Ess Publications.
- [8] Tenopir, C. (2003). Use and Users of Electronic Library Resources: An Overview and Analysis of Recent Research Studies. *Council on Library and Information Resources*.
- [9] Venkadesan, S., Jagannath Uma and Puttabasavaiah (2004). Strategic Planning and Policy for Collection Development of E-Resources to Satisfy User Requirements: A Case Study of J R D Tata Memorial Library. *2nd International CALIBER-2004*.

# Utilizing Institutional Repositories and Content Management Systems for Information Preservation and Dissemination: A Focus on D-Space and Drupal

**V. Bharathkumar**

Assistant Librarian, Sri Sathya Sai University for Human Excellence, Karnataka, India  
E-mail: bharathkumarvshetty0@gmail.com

## **Abstract**

*The present paper describes about the concepts Institutional Repository and Content Management System. These are the two initiatives of libraries which provide web based access to scholarly content and various kinds of information resources. And created new ways for information storage and dissemination in the modern information society. The paper mainly focuses on the open source software's Dspace which is used to create an Institutional repository and Drupal which is used to create websites. How this two software's helps libraries in preservation and dissemination of information? Why libraries prefer these two software's? And the uniqueness of this two software's is described in this paper. The author also identified and try to describe the excellent features of Dspace software and extraordinary modules of Drupal software to emphasize its importance. Finally, the paper revealed that Dspace is the best software for developing institutional repositories and Drupal is the best software for developing library website. Both software's playing vital role in the current world in preservation and dissemination of information.*

**Keywords:** D-space, Drupal, Content Management System, Institutional Repositories, Web Technology, Information Preservation, Information Dissemination, E-Resources.

## **Introduction**

The library is a dynamic social organization. It is expanding its scope using advanced technology. It is day by day changing its nature of services according to user expectation. To facilitate better information services to the user community and to establish a connection between user and the library resources. In this process libraries have become traditional to digital libraries. The situation demands such transformation. As we know the current world is known as digital or technological world. The invention of internet and smart phones made people too smart. Today primary school student to research scholar everyone relies on internet and smart phones for information. It says that the people expecting information in digital form and they feel electronic resources are more convenient than print resources. Such transformation amongst people, provoke the library professionals to think more about digitalization of resources and establishment of digital libraries. The library which is having electronic resources and facilitating information services via internet using different types of software and hardware equipment's, web based tools and technologies is known as digital library. The technologies also impact on information industries by that effect e-books, e-journals, online databases, research tools came into existence. The newly emerged various types of electronic resources requires different types of software and hardware equipment's. Gradually a number of new tools and techniques evolved in the field of library and information science for the preservation and dissemination of electronic information resources. Integrated Library Management system such as KOHA, Libsys, Content Management System such as Joomla, Drupal, Wordpress, Institutional Repository Software such as D-Space and e-prints and Electronic Resource Management System such as CORAL, FOLIO plays a vital role in the preservation, dissemination and overall management of electronic resources.

We cannot imagine the concept of digital library without software's, internet connectivity, electronic devices and electronic resources. Some of the software's plays a major role in building a digital library and also facilitating effective information services to the user community. In the present scenario the open source software's related to Institutional repository and Content Management System were playing a vital role in preservation and dissemination of information.

### **Institutional Repository**

The institutional repository is an initiative of library professional to preserve and facilitate access to its scholarly content. The name itself is a combination of two terms institution and repository. Here the word institution refers to an organization and the word repository refers to its central store house of scholarly content. It is a repository of an organization or institution scholarly output. It is a central place to store, preserve and disseminate scholarly publications of an organization.

Here repository is central databases that preserve or store the various types of scholarly content of an organization. And facilitate web based access to stored content. When user requires information, he/she can retrieve the needed information or documents from that central repository. Institutional Repository is a web based technique that will not take much time and user can access it anywhere anytime.

### **Purpose of Institutional Repositories**

1. The main purpose of this initiative is as follow:
2. To preserve the research output or scholarly content of an organization in a systematic way. To exhibit the research strength of the organization.
3. To establish a simple mechanism for accessing an institutions scholarly content. To analyse the major research activities ongoing in the institution.
4. To facilitate uninterrupted access to the scholarly content.
5. To save the time of the user.

### **D-Space Institutional Repository Software**

There are number of Institutional Repository software's available. But D-Space is one of the best among them. It was developed by MIT and HP Lab and it is non-proprietary software. It is freely available and we can make modifications to software according to our requirements. It is more popularized by its featured plugins and ease of use. It will help us to create a web based institutional repository for scholarly content.

### **Important Features of the Software D-Space**

Some of the features of D-Space institutional repository software are as follow:

#### *1. Open Source Software*

D-Space is a non-proprietary software. It is freely available to all. We can use it as we need and there are no restrictions. If we need any modification in the software, we are free to modify. Nowadays libraries facing financial problems to purchase software and hardware equipment's for initiating institutional repositories. So freely available software D-Space is a better option for libraries to initiate institutional repositories.

#### *2. Excellent System*

D-space is having a systematic process for preserving and retrieving information. It is well programmed. It doesn't create any confusion among staff while uploading and among users while accessing the deposited content.

### 3. Compatibility

D-Space can preserve various forms of digital content. It supports all types of document and media formats. And the software also compatible with different operating systems such as windows, Ubuntu, mac etc.

### 4. Information Model

D-Space having a hierarchical information model. It will help us to segregate the documents according to discipline and division. The following diagram will show the information model of D-Space.

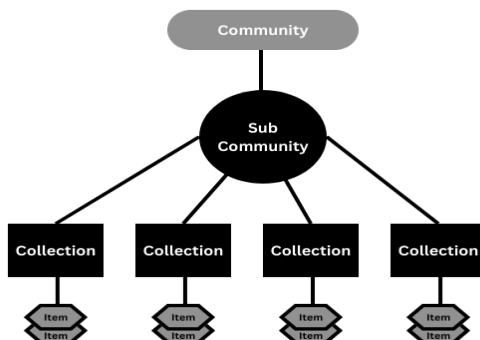

Fig.1 Community

### 5. Administration

D-Space is having one administrator and the administrator has all the privileges. The administrator can create multiple e people by giving limited privileges. This mechanism helps us to distribute workflow of institutional repository among library staff.

### 6. Simple and Systematic Workflow

The institutional repository system setup by using D-Space has multiple stages to upload an item. In the first stage editor submit the document with adequate metadata such as title, authors, abstract, publisher, publishing year, keywords, DOI, ISSN, ISBN, subject, copyright details, funding details, references etc. Then in the second stage reviewer review the document submitted by an editor and he send the same document to admin. In third stage admin one more time check the document and metadata and he finally upload it to repository. This systematic process will avoid human errors.

### 7. Web Based Access

The D-Space will create a web based online database called institutional repository. And user can easily access it from anywhere anytime on web. Only they need internet connection and electronic devices such as smartphones, i-pad, laptops and computer. The present digital environment needs this kind of information dissemination channels. The Institutional Repository is a best initiative by libraries. It will preserve an organization's precious scholarly content on a central database and facilitate web based access to that preserved content. Today information is growing rapidly especially in digital form, the preservation and dissemination of these rapidly generating information is a tedious task for information professionals. In such situation the institutional repository is a best technique for them to preserve and disseminate scholarly content.

## **Content Management System**

Today administration, business, education, health centres each and every sectors of the society have been transformed to digital. For promoting themselves among people these service oriented and also commercial organization developed their own website. The website is a collection of web pages that are interlinked. It is a collection of web pages which has detailed and adequate information about respective organization. Nowadays it has become a connecting bridge between entrepreneurs and customers. The emergence of smart phones and high speed internet attract people towards e-commerce and digital communication. Initially websites are developed by programmers who know programming languages such as html, CSS etc. In earlier days developing a website is a highly skill based task and programmer's costs too much amount to develop a website. To overcome from this expensiveness, the concept of Content Management System was emerged.

Content Management System is web based software that allows us to develop a dynamic website. It allows us to store data on database and create a digital environment to access the stored data. The extraordinary feature of this software is that, without having the prior knowledge of programming language we can develop website. Its block based system, pre- defined content structure and backhand programs made it as a readymade website developing tool. The developer can easily edit the existing content, add the new content. Here content can be text, images, audio recording, videos, documents and other digital assets. The content management system is used for managing and exhibiting the digital content publicly on website. There are number of commercial and open source content management system available on the web. Some of the most popular content management systems are Drupal, WordPress, Joomla, Thunder, contentDM etc.

## **Libraries and Content Management System**

Most of the esteemed educational institutions in India such as IITs, IIMs, IISc., are using content management systems for its library websites. The content management system is a best tool to exhibit various types of electronic resources on the web through a dynamic website. The Drupal and WordPress are available freely having excellent features, so being a service oriented social organization libraries using content management system to develop its websites. This is cost effective software for libraries to manage its electronic resources and to provide access to its subscribed electronic resources. It will set up a single access gateway to different types of digital content or resources of a library.

## **Drupal the Content Management System**

Drupal is one of the featured content management systems developed by Dries Buytaert in the year 2000. Nowadays it is more popularized by its extraordinary modules. It is available freely with a bunch of excellent features so today most of the people using Drupal for their business. Especially it is the recommended content management system for libraries which are having various kinds of digital resources. Because we can easily manage different types of digital content with Drupal. Some of the excellent features of Drupal are:

1. It does not require expertise in programming to develop a dynamic website.
2. It is open source software; we can modify the software according to our requirement.
3. It is multilingual; we can translate the content to local languages.
4. It can support different types of multimedia content.

## **The Featured Modules of Drupal**

Drupal is an excellent Content Management System with a number of modules. Each module helps us to perform a particular task or activate particular feature on the website. Today maximum number of people using Drupal only because of its extraordinary modules. The featured modules



of Drupal made it as one of the most popular and flexible Content Management Systems. Some of the most popular modules of Drupal are:

#### *1. API Module*

This module will provide some standard documentation to a programmer regarding how to develop a standard website. It is something like a Drupal coding standard. Any Drupal developer can contribute his documentation to public on [api.drupal.org](http://api.drupal.org) by using API module.

#### *2. Accelerated Mobile Pages (AMP)*

It is a free html framework to enhance the functionalities of web pages on smartphones. Basically it will reduce the loading time of webpages on smartphones.

#### *3. Advanced Views RSS feed*

The web 2.0 component RSS feed help user to get automatic updates from the chosen website and online portals. The advanced views and RSS feed module of Drupal enable us to create a customizable RSS feeds according to views.

#### *4. Backup and Migrate*

It enables to take complete backup of the website including all kinds of files and data. And it allows migrating the site to different environment by extracting backup in zip, gzip and bzip formats. Here we can also schedule automatic backups.

#### *5. Notify*

It enables us to create an email notification system. First viewers have to subscribe with their email ids to this notification system. Then if the content of the website updated or removed instantly the notification goes to subscribed viewers. They can also subscribe for a particular content to get notification only when changes happen to that particular content.

#### *6. Password Policy*

This module enables developer to restrict website access to a group of users by defining password policies. Only authenticated users can access the website with login credentials.

#### *7. Quiz*

It enables us to create a quiz program on website by adding series of questions and options to choose answer. The administrator can monitor the quiz and finally reveal the scores and results by enabling this module.

#### *8. Entity Print and Entity Share Modules*

The module entity print enables to take print out of any content view as it is from the website in pdf form. And the entity share enables to share any type of the content from the website. The Content Management System Drupal is available with several modules in this paper we have discussed some of the most usable module. And the modules which are very much essential for a library website in the present scenario are highlighted here. Overall Drupal is a best tool for a website developer. And it is best software to create a single access point in the form of website to various types of library resources.

### **Conclusion**

Overall the paper tries to describe the two major initiatives of libraries that are Institutional Repositories and Library website. And the open source software's used for developing those initiatives. The present society which is totally effected by advanced technologies and electronic

resources made libraries to adopt emerging technologies to facilitate information services. The open source software's D-Space and Drupal Plays a major role in preservation and dissemination of information. Today most of the libraries and educational organizations were using these two open sources software's to develop institutional repositories and websites. Both the concept Institutional Repository and Content Management System are old but the highly featured open source software's D-Space and Drupal made it evergreen. In this digital world we library professionals must utilize software's like D-Space and Drupal techniques like Institutional Repositories and Content Management Systems to facilitate effective information services and to satisfy the user community by providing adequate information at the right time.

## References

- [1] Bharathkumar, V. (2020). Virtual Reference Service through Mobile App Developed Using MIT App Inventor: An effective tool for Librarians in Covid-19 Pandemic Scenario. *IJLIS*, 10.
- [2] Caron, B., Toole, D., Wicks, P., & Miller, S. (2011). DigitalOcean: building a platform for scientific collaboration and social and media sharing on the Drupal content management system. *Earth Science Informatics*, 4, 191-196.
- [3] Davis, P.M., & Connolly, M.J. (2007). Institutional repositories: evaluating there as on s for non-use of Cornell University's installation of D-Space.
- [4] Dombrowski, Q. (2016). Drupal and other content management systems. *Doing Digital Humanities: Practice, Training, Research*, 289-302.
- [5] Fennell, C.M. (2018). Content management and Web 2.0 with Drupal. In *Medical Librarian 2.0* (pp.143-167). Routledge.
- [6] <https://www.drupal.org/>
- [7] Iqbal, M., Noman, M., Talpu, S. R., Manzoor, A., & Abid, M. M. (2020). An empirical study of popular content management system- word press vs drupal vs joomla. *ICTACT Journals*, 1214-1219.
- [8] Kishore, A., & Seshaiyah, O. (2014). Drupal: Developing Library Portal Using Open Source Content Management System. *Library Space and Content Management for a Networked Society*, 201.
- [9] Kumar V, Bharath. (2022). Digital Transformation: Need for the Transformation of Libraries into Digital Libraries.
- [10] Kumar V, Bharath. (2023). E-Resources and the Five Laws of Library Science.
- [11] Kumar, B. Library Services in the Post-Matric Hostels of Social Welfare Department in Chikkamagaluru District: A Survey.
- [12] Lubas, R.L. (2009). Defining best practices in electronic thesis and dissertation metadata. *Journal of Library Metadata*, 9 (3-4), 252-263.
- [13] Lynch, C.A. (2003). Institutional repositories: essential infrastructure for scholarship in the digital age. *Portal: Libraries and the Academy*, 3(2), 327-336.
- [14] Ogunrinde, M. A., & Yoosuf, T. H. (2016). Performance Analysis on Content Management Systems: A Case Study of Drupal and Joomla. *Auditing*, 4, 6.
- [15] Rawtani, M.R., & Chidambaram, S.S. (2009). Drupal: The Open Source Content Management System Software Suit for Library with Library 2.0 Features.
- [16] Rieh, S.Y., Markey, K., St. Jean, B., Yakel, E., & Kim, J. (2007). Census of institutional repositories in the US. *D- Lib magazine*, 13 (11/12), 1082-9873.
- [17] Smith, M., Barton, M., Bass, M., Branschofsky, M., McClellan, G., Stuve, D & Walker, J.H. (2003). D-Space: An open source dynamic digital repository.
- [18] Wakode, B.V., & Chaudhari, D.N. (2013). Study of content management systems Joomla and Drupal. *IJRET: International Journal of Research in Engineering and Technology*, 2(12), 569-573.

# Digital Information Literacy Among Selected Engineering Students: A Study

S. Sheeba<sup>1</sup> and Dr. S.Vijayakumar<sup>2</sup>

<sup>1</sup>Research Scholar, DLIS, Nallamuthu Gounder Mahalingam College, Pollachi, Tamil Nadu, India

<sup>1</sup>Librarian, Arjun College of Technology, Coimbatore, Tamil Nadu, India

<sup>2</sup>Librarian & Research Supervisor, DLIS,  
Nallamuthu Gounder Mahalingam College, Pollachi, Tamil Nadu, India

E-mail: sheeba.sheeba.mahendran@gmail.com, Librarian@ngmc.org

## Abstract

*This study examines the degree of digital information literacy among engineering students at Anna University in Chennai, which is connected to colleges such as Sri Eshwar College of Engineering (SECE), Akshaya College of Engineering and Technology (ACET), and Arjun College of Technology (ACT). An attempt has been made to determine the students' level of information literacy competency in this study. For the purpose of gathering data, a questionnaire was created and given to each college's students. Ninety percent of the respondents 42 from ACT, 47 from ACET, and 46 from SECE—responded. The study's findings demonstrate that electronic journals are the most important information source for all students. The percentage of students who use search engines is high (68.8%). Additionally, the results showed that students' top priority is gathering study materials through the use of electronic resources. It is discovered that objectivity (67.4%) is the most crucial factor in students' assessments of online resources.*

**Keywords:** Information Literacy, Digital Information Literacy, Engineering students

## Introduction

The digital era is changing quickly, and people in many fields including engineering need to be able to access, assess, and use information efficiently. It is essential to provide engineering students with the skills they need to traverse this ever-changing information landscape, given the rapid expansion of digital technologies and the exponential growth of information sources. Through an examination of DIL's introduction to a particular cohort of engineering students, this study seeks to determine how it affects the students' academic performance, capacity for problem-solving and general preparedness for the demands of the digital age. Information seeking, critical source evaluation, ethical information use, and effective findings communication are just a few of the competencies that make up digital information literacy. DIL is especially important in the context of engineering education because it equips students with the skills necessary to succeed in the modern workplace, where information and technology are indispensable, as well as improving their academic performance.

The engineering students who have been chosen will participate in a structured intervention program aimed at improving their DIL. Participating in this program will give you practical experience with digital research techniques, using academic databases, critically analyzing internet sources, and following proper citation guidelines. The study will also investigate how to incorporate cutting-edge tools for information retrieval and analysis—like artificial intelligence and data analytics—into the DIL curriculum. This will guarantee that students are prepared for this kind of work. The study will use a mixed-methods approach, integrating qualitative information from focus groups and interviews with quantitative data from pre- and post-intervention assessments, academic performance metrics, and surveys. The aim of this study is to present a thorough understanding of how DIL affects the academic trajectory and readiness of the chosen engineering students for the information-rich professional environment.

### **Objectives of the Study**

1. To know which type of e-resources needed among the students
2. To know Purpose of using e-resources
3. To know the types of the devices used for ICT
4. To know preference of using the Web search tools
5. To know the evaluation rating of the e-resources

### **Review of Literature**

(Mardani, P.B , 2021) and Herdiyana Fitriani & *et al.*, ( 2023) focus on the digital information literacy skills of university students, with using the Seven Pillars of Information Literacy framework and finding that students possess strong digital information search skills but lack knowledge about research papers outside their university's guidelines, through a cross-sectional survey, concludes that students' digital literacy skills are generally good, with high engagement in internet access for assignments and the creation of new forms of information .

Douglas, K.A & *et al.*, (2014) and Mamoona Kousar & Khalid Mahmood (2015) explore self-assessment of information literacy skills, with finding no significant difference between first-year and junior engineering students' self-reported information literacy skills, despite previous research indicating otherwise. Assesses faculty perceptions of engineering students' information literacy skills, revealing that faculty perceive PhD students to have higher information literacy skills than MS students.

Liu, G. (2021) examines the impact of an information literacy session on international graduate engineering students, finding significant improvement in certain aspects of information literacy but not in identifying and evaluating information.

Vyas, P. R., & Chak, A. D. (2022) provide insights into the digital information literacy skills among women students in higher education and Indonesian Language and Literature Education Study Program students, respectively. Both studies highlight the importance of digital literacy and the need for technical skills development.

Balint, D. M. (2016) discusses the integration of information literacy into coursework, emphasizing the importance of these skills for engineering and science students in higher education, while profiles 21st Century Skills and Information Literacy among Indonesian Language and Literature Education students, indicating a need for improvement in critical thinking, communication, and information literacy skills.

### **Methodology**

With the above technological background, the present survey was limited to three engineering Colleges Anna University, Chennai affiliated colleges of (Arjun College of Technology (ACT) & Akshaya College of Engineering And Technology (ACET) & Sri Eshwar College of Engineering (SECE) from Southern region Coimbatore of Dist, Tamil Nadu. Hereafter, abbreviated forms of these institutions are used throughout the paper. In this study, an attempt has been made to know the level of digital information literacy among the engineering students. Questionnaire method as a tool for data collection was used to fulfil the objective of the survey. 50 questionnaires were distributed in each institutes among students who were present in the library and received back 42 (84%) from ACT, 47 (94%) from ACET and 46 (92%) from SECE. The response rate was 90%. The chi-square test was used at 0.05 % level of significance to know the variation of digital information literacy among the engineering students.

### Hypotheses

The following null hypotheses were formulated and tested by employing chi-square statistical tool.

- H1– There is no significant difference between the student’s e-resources need.
- H2– There is no significant difference in purpose of using e-resources by students.
- H3– There is no significance difference between types of the devices used for ICT.
- H4– There is no significance difference in use Web search tools by student.
- H5– There is no significance difference in evaluation of e-resources by the Student.

### Data Analysis

TABLE I TYPES OF E-RESOURCES NEEDED

E-resources	Respondents			Total	$\chi^2(df;c)$	p
	ACT	ACET	SECE			
E-Databases	12	23	29	64	27.94* (12,21.03)	P=0.01
E-Books	16	41	37	94		
E-News	0	3	7	11		
E-Journals	42	47	46	135		
E-Magazines	3	13	21	37		
E-Thesis	9	22	27	58		
E-SubjectGateway	0	8	13	21		

In response to the question how much type of e-resources is needed, Table I indicates that e-journals is most needed e-resources source of all students of ACT, ACET and SECE. 69.6% (11.8% from ACT, 30.4% from ACET and 27.4% from SECE) of the students need the e- books for e-resources, followed by 47.4% (8.9% of ACT, 17% of ACET and 21.5% of SECE) e-databases, 42.9% e-thesis and 27.4% e-magazines. Whereas, e-subject gateway (15.5%) and e-news (8.1%) are less needed as e-resources sources by the students. The calculated value of  $\chi^2$  (27.94) is greater than the critical value (18.31), i.e.,  $27.94 > 21.03$ . This shows that there is significant difference among the engineering students needs of e- e-resources. It is identified with the statistical analysis of Chi-square the structured hypothesis H1 is rejected at 0.05 level of significant.

TABLE II PURPOSE OF USING E-RESOURCES

Purpose	Respondents			Total	$\chi^2(df;c)$	p
	ACT	ACET	SECE			
Assignment	22	29	35	86	40.51* (10,18.31)	P =0.00
For study	34	47	46	127		
To update subject Knowledge	42	44	46	132		
To collect study Materials	42	47	46	135		
To connect with professionals group	0	43	46	89		
To carry out project work	20	47	46	113		

Every student has a purpose to use e-resources with different approach. An attempt was made to know which purpose is on the highest rank among engineering students. Table II shows the

college wise students purpose of using digital resources. The SECE students have the top position with respect to their overall purpose of using e-resources except Assignment (26%). The ACET students give the first preference to e-resources for study (34.8%), to collect study materials (34.8%), to carry out project (34.8%). Whereas e-resources are used to update subject Knowledge, work to connect with professionals group and Assignment by 32.6%, 31.8% and 21.5% of ACET students respectively.

The ACT students give top response using e-resources to update subject Knowledge (31.1%), to collect study Materials (31.1%), for study (25.2%) whereas less responses given to Assignment (16.3%) and to carry out project (14.8%). It is noted from the result that the purpose to collect the study material among students has the highest rank with usage digital resources. The chi square is significant at 0.05 level of significance. It is indicated that there is significant variation among student usages to e-resources and based on the statistical result the structure null hypothesis H2 is rejected.

TABLE III TYPES OF THE DEVICES USED FOR ICT

Device	Respondents			Total	$\chi^2(df;c)$	P
	ACT	ACET	SECE			
Desktop	24	37	32	93	22.98* (8,15.51)	P= 0.0034
Tablet	18	10	14	42		
Laptop	38	31	36	105		
I-Pad	0	6	12	18		
Mobile Phone	23	47	46	116		

To know the Types of the devices used for ICT, students were asked to indicate their devices used for ICT. It is evident from Table III that 34.1% of SECE students have devices used for ICT of Mobile Phone, followed by 26.6% of Laptop and 23.7% of Desktop. The ACET students have used for ICT Mobile Phone (34.8%), Laptop (27.4%) and Laptop (23%). Whereas ACT students have devices used for ICT of Laptop (28.1%), followed by Desktop (17.7%) and Mobile Phone (17%).

It is noticed from the table that the the devices used for ICT Desktop and I-Pad are low among all students. Chi-square test results do not support the null hypothesis and there is significance difference between the used for ICT of students and structured null hypothesis H3 is rejected.

TABLE IV USE OF WEB SEARCH TOOLS

Web Search Tools	Students			Total	$\chi^2(df;c)$	P
	ACT	ACET	SECE			
SearchEngine	22	38	33	93	19.68* (10,18.31)	P= 0.03
SubjectGateway	0	5	12	17		
Online Database	4	7	6	17		
DigitalLibrary	3	3	5	11		
MetaSearchEngine	0	1	9	10		
WebPortal	13	27	39	79		

There are different types of web search tools. Table IV shows that high percentages (68.8%) of the search engine are used by all students. Web Portal search tool is the second preference by students of ACT (9.6%) and ACET (20%) whereas SECE students have first preference to use Web Portal. It is found from the table that other web search tools like Subject Gateway, Online Database, Digital Library and Meta Search Engine are less preferred by the all students. The value of chi-square is 19.68 and degree of freedom is 10. The value of p (0.03) reveals the statistically significance ( $p < 0.05$ ). The variation among students has been found as far as web search tools are concerned.

TABLE V EVALUATION OF E-RESOURCES BY THE STUDENTS

Evaluation	Students			Total	$\chi^2$ (df;c)	p
	ACT	ACET	SECE			
Reliability	19	21	24	64	7.76* (16,26.30)	P= 0.96
Authenticity	21	15	18	54		
Accessibility	25	26	30	81		
Objectivity	28	32	31	91		
Usability	17	23	27	67		
Comprehensive	9	17	19	45		
Expensive	10	17	15	42		
Exposure	9	16	18	43		

In order to know the evaluation rating of the e-resources by the students, a question has been put to the students. The replies given by them are shown in Table V. The analysis of the data shows that objectivity (67.4%) is the most important criteria for evaluation of e-resources followed by accessibility (60%), usability (49.6%) and reliability (47.4%). The chi-square test is significant at 0.05 level of significance. There is no significant variation in evaluation of e-resources by the students. It has been found that the calculated value is less than the critical value at 0.05 level of significant and the structure null hypothesis  $H_5$  is accepted.

**Conclusion**

In order to fully utilize the potential of new technologies and engage in economic, social, and cultural life, students must possess the knowledge and skills required by the new academic community model. Finding out the level of digital information literacy among the chosen engineering college students is the goal of the current study. The study discovered notable variations among students concerning the need for and use of electronic resources, types of ICT devices, and Web search tools, with the exception of e-resource evaluation. The findings, however, indicate that the majority of engineering students rely on electronic journals as their primary source of information and utilize search engines to find study materials online. According to the survey, a smaller percentage of students say they do not prefer electronic databases and e-subject gateways as e-resources, but fewer of them say they use these tools for assignments and projects. It is observed that every student uses a low-end iPad, tablet, and desktop computer for their ICT needs. The survey's findings also show that not all students are as interested in using web search engines, subject gateways, online databases, digital libraries, and meta search engines. Digital information literacy must be developed if an entirely online learning environment is to be created and students are to become more aware of digital resources. Every engineering college has access to a variety of digital information resources, and libraries can be crucial in helping students become digitally literate.

## References

- [1] Balint, D. M. (2016, April). Supporting information literacy development of engineering students in research-based composition courses. In 2016 IEEE Global Engineering Education Conference (EDUCON) (pp. 802-807). IEEE.
- [2] Douglas, K.A., Wertz, R.E., Fosmire, M.J., Purzer, S., & Epps, A.S. (2014). First-Year and Junior Engineering Students' Self-Assessment of Information Literacy Skills.
- [3] Herdiyana Fitriani & *et al.*, (2023) Digital Literacy Ability of Students of Biology Education Study. *Journal of Research in Science Education*, March 2023, Volume 9 Issue 3, 993-1000.
- [4] Liu, G. (2021). Information literacy instruction for international graduate engineering students: A case study at University of Windsor. *The Journal of Academic Librarianship*, 47(5), 102415.
- [5] Mamoona Kousar & Khalid Mahmood (2015). Perceptions of Faculty about Information Literacy Skills of Postgraduate Engineering Students, *The International Information & Library Review*, 47:1-2, 52-57, DOI: 10.1080/10572317.2015.1055694
- [6] Mardani, P.B., & Silalahi, R.R. (2021). The Digital Information Literacy Skill Level on College Student (Case: Final-Year College Student). *International Journal of Multicultural and Multireligious Understanding*, 8, 197-206.
- [7] Vyas, P. R., & Chak, A. D. (2022). Awareness of Digital Information Literacy Skills among the Female Students of Gujarat University Library, Ahmedabad: A Study. *Towards Excellence*, 14(3).



# Web Presence of Library Consortia: A Webometric Study

Richa Arya<sup>1</sup> and Aman Verma<sup>2</sup>

<sup>1</sup>Librarian, <sup>2</sup>Senior Research Fellow,

<sup>1</sup>Kendriya Vidyalaya (KVs), Karimnagar, Telangana, Andhra Pradesh, India

<sup>2</sup>Dept. of Library and Information Science, University of Lucknow, Lucknow, Uttar Pradesh, India

E-mail: richaarya095@gmail.com, vermaaman.1443@gmail.com

## Abstract

*In the context of this research, the author studied webometric analysis of websites of selected library consortiums. The three types of Web Impact factor (WIF), which were simple Web Impact factor (SWIF), In links web impact Factor (IWIF), and external web impact factor (EWIF) were calculated, and also finds NWP (number of webpages), Number of inlinks and number of external links and various webometric indicators were calculated in this study. The data were collected using the Google search engine and SEO review tools. The findings of the study show that the website of the Center for Research Libraries (CRL) has a total of 1,37,70,000 files followed by the website of GALILEO (Georgia Library Learning Online) with 74,30,000 and ARL with 42,16,000 files. The website of CRL has maximum number of web pages has 0.000003 SWIF, 0.000003 IWIF, and 2.02312139 ELWIF. The website of California Digital Library (CDL) with a score of 31 has the slowest load time among all in the mobile version followed by the website of GALILEO with a score of 40.*

**Keywords:** Webometrics, Library consortium, Web impact factor, USA.

## Introduction

In this technological era, libraries, documentation, and information centers have started acquiring and maintaining new forms of information resources such as e-journals, e-books, online databases, e-documents, etc. The rise in prices of e-journals and publications has necessitated the formation of a library consortium by the library community. The library consortium concept brings different member libraries together to achieve the goal of working as a team. Today, websites are used by people, organizations, and other entities as a tool to communicate and to advertise their capabilities as well as to give services to their customers, not just to showcase their expertise but also to provide their clients services. The main purpose of the consortium website is to provide shared access to electronic resources through the Internet and by forming a consortium among libraries; it becomes possible to purchase information at stabilized and reasonable prices.

## Library Consortium

Consortia “is a plural form of “consortium “but is often used in a singular form. Consortium is derived from the Latin word “consort” which means partnership. A library consortium is a group of libraries that come together to achieve a common goal that reasonably requires collaboration and resource sharing. The library consortium is mainly concerned with the sharing of resources in digital or electronic form. The aim of the consortia is to achieve what the members of the group cannot achieve individually. Several factors support the necessity for consortia, including information explosion; the amount of information being produced has greatly increased as a result of the extensive study being done in practically every subject of expertise. Information is offered in a variety of formats and ways. For libraries, achieving self-sufficiency is impossible. A consortium is better equipped to handle and address the issues associated with preserving and archiving electronic resources. Another factor is budget, the price of books and other sources of information is rising daily. Thus, a consortium makes it possible for its member libraries to purchase the electronic resources at a reasonable price. Also, library users want to have access to

the material as soon as possible and many of them want information in online format. The web-based electronic resources are proper a means to meet the expectations of users.

### **Review of Literature**

Verma and Jaiswal (2020) conducted a webometric study of the top thirty medical universities in India and calculated the various types of Web Impact Factors. For counting the inlinks, external links, and total links; SEO Review Tools (a link analyzer tool) has been used. (<https://www.seoreviewtools.com/seo-checker/>) has been used. The findings of the study show that Aligarh Muslim University with WISER index value 14.919 ranked as first and JSS Medical College had the lowest rank. The website of SRM Institute of Science and Technology can be considered as having the fastest load time on google search with a score of 84 for the desktop version and 71 for the mobile version.

Arya and Jaiswal (2020) analyzed the websites of repositories of Indian Institutes of Technology (IITs), and they calculated the overall Web Impact Factor, Simple Web Impact Factor, Self-Link Web Impact Factor, External Link Web Impact Factor and Inlink Web Impact Factor. The study used Google to collect raw data, i.e., the number of web pages, number of inlinks, self-links and external links. The finding of the study shows that the Top Level Domains of IITs Institutional repositories websites are .ac.in and .ernet.in. The TLD.ac.in is used by 91% of repositories. 84.62% IIT Repositories use PDF files followed by HTML 69.23% and DOC files 38.46% and MS-PowerPoint 7.69%.

Verma and Brahma (2017) have conducted a webometric study of North East Central Universities in India. Under this, the authors have studied the link page; number of pages; and web impact factor of the universities taken for the study. The study finds that according to the domain authority, external equity passing links, and total external links Tezpur University secured the first position. Whereas Mizoram University secured the first position in the internal equity passing links, total equity passing links, total internal links, and total links. The authors reveal in their study that Mizoram University holds the first rank with 83.54 SWIF, 52.73 IWIF, and 30.80 EWIF among the central universities taken for the study.

Verma and Devi (2016) examined the web content and design trends of the Indian Institutes of Management (IIMs) libraries website. A checklist was designed, and the library webpages were evaluated based on the previous evaluations of websites conducted by different authors. The authors found that all the IIMs library webpages are different in themselves in many respects. Their study reveals that only 7 IIMs out of 12 IIMs have their separate library web pages. The other 5 IIMs, IIM Raipur, Rohtak, Ranchi, Udaipur and Shillong have a dedicated library page in their respective IIM websites.

Chakravarty & Wasan (2015) conducted a webometric analysis of library websites of higher educational institutes of India. The authors conducted this study through the Google search engine. and calculated the web Impact factor (WIF) and R-WIF (Revised WIF) of the top ten library websites of HEI of India. By calculating these, it concludes that while evaluating through both the formulas whereas half of the library websites secured different ranks while ranking through WIF and R-WIF.

### **Objectives of the Study**

The objective of the present study is to analyze the websites of selected library consortia in the USA. The specific objectives of the study are to:

1. To find the number of web pages, number of inlinks, and number of external links.
2. To measure the Simple Web Impact Factor (SWIF), Inlink WIF (IWIF), and External WIF (EWIF).
3. To find the number of rich files.
4. To find out the Page Speed Insight (PSI)
5. To identify the Domain authority & Page authority.

### Scope & Methodology

The scope of the present study is limited to the selected Library Consortia websites available in the United States of America. For the collection of data, we used Google search engine for calculating the total number of webpages (NWP) using the command domain: www.example.com. For counting the inlinks, external links, total links; SEO Review Tools (a link analyzer tool) has been used. (<https://www.seoreviewtools.com/seo-checker/>) has been used.

Rich files are complete and independent items in different formats (such as Adobe Acrobat (.pdf), Microsoft Excel (.xls), Microsoft Word (.doc), and Microsoft PowerPoint (.ppt). The number of file formats for each university was obtained on Google with the following strategy: site: example.com file type: example file format. For example, 'site: www.amu.ac.in file type: pdf' for retrieving the total number of .pdf files that the website contains:

### Calculation of Web-Impact Factor

TABLE I CALCULATION OF WEB-IMPACT FACTOR

Simple WIF (SWIF)	$\frac{\text{Total no. of Links (Internal + External)}}{\text{No. of Webpages linked to the Website (NWP)}}$
Internal WIF (IWIF)	$\frac{\text{Total no. of Internal Links}}{\text{No. of Webpages (NWP)}}$
External WIF (ELWIF)	$\frac{\text{Total no. of External Link}}{\text{Total no. of Webpages (NWP)}}$

TABLE II LIST OF SELECTED CONSORTIUMS

S.No.	Library Consortium	Abbreviation	URL
1	Academic Libraries of Indiana	ALI	<a href="https://academiclibrariesofindiana.org/home">https://academiclibrariesofindiana.org/home</a>
2	Association of Research Libraries	ARL	<a href="https://www.arl.org/">https://www.arl.org/</a>
3	California Digital Library	CDL	<a href="https://cdlib.org/">https://cdlib.org/</a>
4	Center for Research Libraries	CRL	<a href="https://www.crl.edu/">https://www.crl.edu/</a>
5	Colorado Library Consortium	CLiC	<a href="https://www.clicweb.org/">https://www.clicweb.org/</a>
6	GALILEO (Georgia Library Learning Online)	GALILEO	<a href="http://www.galileo.usg.edu/">http://www.galileo.usg.edu/</a>
7	Hawaii Library Consortium	HLC	<a href="http://web.hawaii.edu/hlc">http://web.hawaii.edu/hlc</a>
8	Illinois Heartland Library System	IHLS	<a href="https://www.illinoisheartland.org/">https://www.illinoisheartland.org/</a>
9	INFOhio	INFOhio	<a href="https://www.infohio.org/">https://www.infohio.org/</a>
10	Library and Information Resources Network (LIRN)	LIRN	<a href="https://www.lirn.net/">https://www.lirn.net/</a>

(Source: <https://icolc.net/participating-consortia>)

## Data Analysis

TABLE II CALCULATION OF WEB IMPACT FACTOR

S.No.	Library Consortium	Web pages	Inlinks	External Links	Total Links	SWIF	IWIF	ELWIF
1	ALI	1,140	30	36	69	0.060526	0.026315	0.031578
2	ARL	24,00,000	86	8	94	0.000391	0.000035	0.000003
3	CDL	2,26,000	156	5	161	0.000712	0.000690	0.000022
4	CRL	3,46,00,000	131	7	138	0.000003	0.000003	0.000003
5	CLiC	3,890	119	2	121	0.031105	0.030591	0.000514
6	GALILEO	19,80,000	22	6	28	0.000014	0.000011	0.000003
7	HLC	9,47,000	95	1	96	0.000101	0.000100	0.000001
8	IHLS	4,010	135	6	141	0.035162	0.033665	0.001496
9	INFOhio	1,04,000	2	0	2	0.000019	0.000019	0.000000
10	LIRN	6,72,000	42	6	48	0.000071	0.000062	0.000008

Table II shows the Simple web impact factor (SWIF), Internal links web impact factor (IWIF) and External web impact factor (ELWIF) and it is clear that the website of ALI has 0.060526 SWIF, 0.026315 IWIF and 0.031578 ELWIF. The website of CRL has maximum number of web pages has 0.000003 SWIF, 0.000003 IWIF and 2.02312139 ELWIF. The website of IHLS has 0.035162 SWIF, 0.033665 IWIF and 0.001496 ELWIF. The website INFOhio has same 0.000019 SWIF and IWIF.

TABLE III NUMBER OF RICH FILE AVAILABLE

S.No.	Library Consortium	PDF	PPT	XLS	DOC	Total Files
1	ALI	2,210	8	8	1,600	3,826
2	ARL	26,000	12,50,000	11,30,000	18,10,000	42,16,000
3	CDL	79,200	23,200	32,300	52,800	1,87,500
4	CRL	96,90,000	11,80,000	10,30,000	18,70,000	1,37,70,000
5	CLiC	4,020	1,610	10,300	8,680	24,610
6	GALILEO	22,10,000	20,00,000	13,70,000	18,50,000	74,30,000
7	HLC	8,98,000	9,42,000	9,47,000	8,75,000	36,62,000
8	IHLS	5,550	5,330	7,970	4,060	22,910
9	INFOhio	17,900	1,03,000	9	16,300	1,37,209
10	LIRN	2,23,000	6,36,000	8	1,81,000	10,40,008

Table III shows the total available rich files over the websites of these consortium, and it clearly shows that the website of CRL has a total of 1,37,70,000 files followed by the GALILEO with 74,30,000 and ARL with 42,16,000 files. The website of ALI has only 3,826 files, IHLS has 22,910 files and the website of CLiC has 24,610 files.

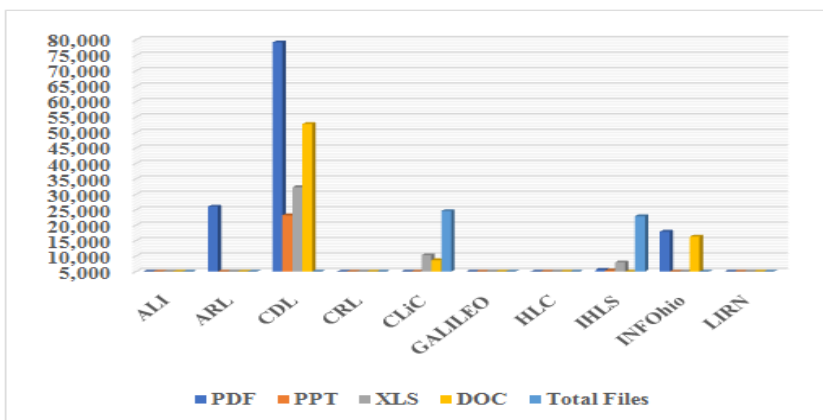

Fig.1 Available Rich Files Over the Websites

TABLE IV GOOGLE PAGE SPEED SCORE

S.No.	Library Consortium	Google Page Speed	
		Mobile	Desktop
1	ALI	87	86
2	ARL	50	94
3	CDL	31	85
4	CRL	84	99
5	CLiC	64	75
6	GALILEO	40	66
7	HLC	82	95
8	IHLS	44	42
9	INFOhio	68	73
10	LIRN	78	85

Page Speed Insight (PSI) reports on the performance of a page on both mobile and desktop devices; a score of 90 or above is considered good, 50 to 90 is a score that needs improvement, and below 50 is considered poor. (<https://developers.google.com/speed/docs/insights/v5/about>).

Table III performance of a web page on both mobile and desktop devices, and it is clear from the table that the website of ALI with a score of 87 has fastest load time among all in mobile version followed by the website of CRL with a score of 84, while the website of CRL with a score of 99 has fastest load time among all in desktop version followed by the website of HLC with a score of 95.

The website of CDL with a score of 31 has slowest load time among all in mobile version followed by the website of GALILEO with a score of 40. The website of IHLS with a score of 42 has slowest load time among all in desktop version followed by the website of GALILEO with a score of 66.

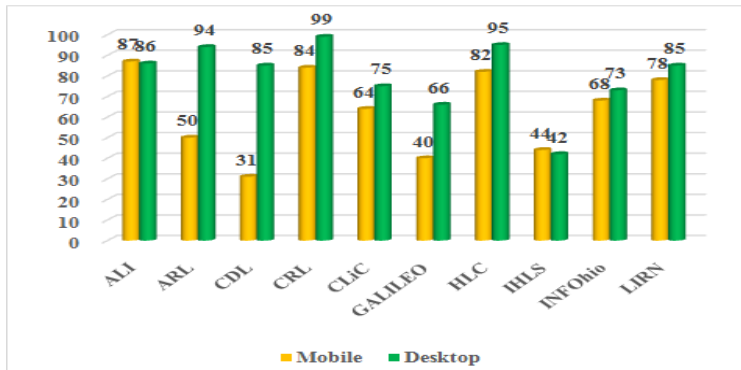

Fig.2 performance of a web page

TABLE V DOMAIN AND PAGE AUTHORITY

S.No.	Library Consortium	Domain Authority	Page Authority
1	ALI	24	28
2	ARL	67	70
3	CDL	71	88
4	CRL	55	85
5	CLiC	37	59
6	GALILEO	74	80
7	HLC	79	0
8	IHLS	49	50
9	INFOhio	65	64
10	LIRN	70	74s

Domain Authority (DA) is a search engine ranking score that predicts how well a website will rank on search engine result pages (SERPs). A Domain Authority score ranges from one to 100, with higher scores corresponding to a greater ability to rank. On the other hand, Page Authority (PA) is a score that predicts how well a specific page will rank on search engine result pages (SERP). Page Authority scores range from 1 to 100, with higher scores corresponding to a greater ability to rank. Table V shows that website has HLC has maximum Domain Authority among all followed by GALILEO with a score of 74. The website of CDL has maximum Page authority with a score of 88 followed by the CRL with score of 85. The website of HLC has zero Page authority.

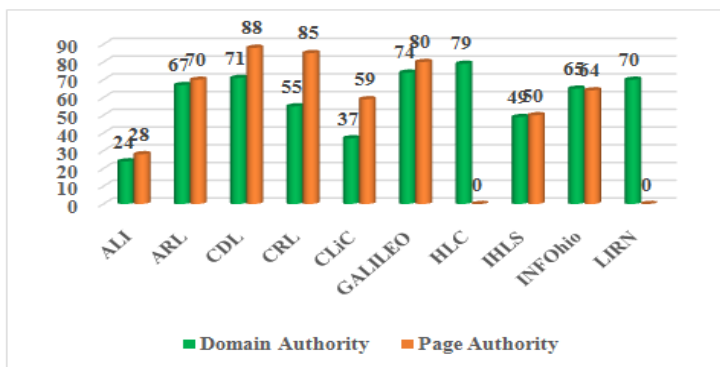

Fig.3 Domain Authority

## Conclusion

In the current digital era, library consortia are essential, and their websites serve as the only source of information because, without them, users and web surfers would not be able to access high-quality materials. This study provides information about the websites of selected Library consortia in USA and the findings clearly show the present scenario of websites and it is found that The website of CRL has maximum number of web pages has 0.000003 SWIF, 0.000003 IWIF and 2.02312139 ELWIF. The website of CRL with a score of 99 has fastest load time among all in the desktop version. The website of CRL has a total of 1,37,70,000 files which is maximum among all. It gained more benefits when library consortia are connected. Connecting between consortia allows good cooperation with various advantages.

## References

- [1] Arya, R. and Jaiswal, B.2020. Web presence of repositories of Indian institutes of technology: a webometric study. *Journal of Library and Information Sciences*, 8:183-99. doi:10.15640/jlis.v8n1a10
- [2] MOZ. Domain authority. Available at: <https://moz.com/learn/seo/domain-authority>.
- [3] MOZ. Page authority. Available at: <https://moz.com/learn/seo/page-authority>
- [4] Participating Consortia. Available at: <https://icolc.net/participating-consortia>
- [5] Saini, A.2017. Library consortia: an overview. *International Journal of Digital Library Services*.7, 4. <http://www.ijodls.in/uploads/3/6/0/3/3603729/12ijdosl174.pdf>
- [6] Verma, M. K and Brahma, K.2017. Websites of central universities in north east India: a webometric analysis. *DESIDOC Journal of Library & Information Technology*. 37, 3: 186-191
- [7] Verma, M. K. and Devi, K. K.2015. Content analysis of central universities library websites of north eastern states of India: a survey. *Journal of Research in Librarianship*.2(5): 48-59.
- [8] Wasan, R. and Chakravarty. 2015. Webometric analysis of library websites of higher educational institutes (HEIs) of India: a study through google search engines. *DESIDOC Journal of Library & Information Technology*.2015: 325-329.

# Analysis of Digital Library Information Services: A Comprehensive Review

**Dr. P. Krishnamoorthy**

R.M.K. College of Engineering and Technology, Thiruvallur, Tamil Nadu, India

E-mail: krishlib@rmkcet.ac.in

## **Abstract**

*This article provides a thorough examination of digital library information services, looking at its relevance, advantages, difficulties, and potential. Digital libraries have revolutionized how knowledge is accessed, arranged, and shared in a society that is becoming more and more digital. The study examines the essential elements of digital library information services, such as the production and maintenance of metadata, digital preservation, and user interfaces. The advantages of digital libraries are discussed, including better search capabilities, broader user reach, improved resource management, and more accessibility. But there are also difficulties with copyright, outdated technology, information overload, and the digital divide that are addressed. Emerging themes are highlighted in the essay, including the use of linked open data, collaborative platforms, and user analytics. It offers insights into productive digital library projects through case studies and best practices. For scholars, librarians, and other professionals looking to comprehend and improve digital library information services in the digital age, this thorough examination is a great resource.*

**Keywords:** Comprehensive Review, Analysis, Digital Library, Information Services

## **Introduction**

Digital libraries have developed as potent platforms for classifying, archiving, and facilitating access to enormous databases of digital resources in the quickly changing world of information management and distribution. As a result of the development of technology, libraries have transformed from conventional physical locations into digital hubs that have completely changed how people access and share information. This article provides a thorough analysis of the main characteristics, difficulties, and opportunities of digital library information services. It attempts to give a clearer understanding of how digital libraries currently function, their effect on information access, and the promise they offer to change how knowledge is shared in the digital era.

The expansion of digital resources, such as e-books, scholarly papers, multimedia content, and historical materials, has prompted the creation of sophisticated information services to assure these resources' effective organization, searchability, and retrieval. To facilitate efficient access and discovery of digital content, digital libraries use a variety of techniques and technologies, such as metadata standards, indexing and cataloguing systems, search engines, and user interfaces.

This review looks at the basic components of digital library information services, such as metadata management, resource discovery, access control, preservation, and user experience. It investigates the difficulties that digital libraries confront in terms of scale, interoperability, copyright concerns, and user involvement. It also looks into the role of developing technologies like artificial intelligence, machine learning, and linked data in improving the capacities of digital libraries.

The study also looks at the advantages of digital library information services, such as increased accessibility, greater discoverability, worldwide reach, and collaborative knowledge generation. It also addresses how digital libraries may effect education, research, cultural preservation, and societal growth.



This comprehensive study intends to shed light on the current state of digital library information services and propose opportunities for future development and innovation by critically reviewing existing literature, research studies, and practical implementations. It aims to add to the existing discussion about digital libraries and their transformative potential in the field of information management. Overall, this article offers a comprehensive study of digital library information services, emphasizing its importance, problems, and potential. It is a significant resource for researchers, practitioners, and policymakers interested in understanding and harnessing the power of digital libraries in the digital age.

### **Overview of Digital Library Services**

Digital library services include a variety of features and functionalities that make it possible to organize, access, and retrieve digital resources efficiently. These services are essential for guaranteeing the efficient management and distribution of content in the context of a digital library. We give an overview of the main elements and features of digital library services in this section.

#### **Metadata management**

Metadata is essential for characterizing digital resources and making them easier to find. Systems for managing metadata, which enable the generation, archiving, and upkeep of descriptive information about resources, are among the services provided by digital libraries. This comprises classification schemes, controlled vocabularies, and metadata standards that improve resource discoverability and speed up search and retrieval.

#### **Resource Discovery**

Users can find and access pertinent digital resources in the library by using resource discovery services. To give users effective and precise search results, these services make use of advanced search functionality, indexing strategies, and search algorithms. To improve the user experience, resource discovery services may additionally offer browsing options, faceted search, and personalized suggestions.

#### **Access Control**

To manage and control user access to resources, digital libraries frequently use access control systems. Services for access control include user management tools, licensing agreement- or copyright-based usage limits, and authentication and authorization systems. These services provide authorized users to access and use digital resources while ensuring their security and privacy.

#### **Preservation**

For the long-term integrity and accessibility of digital information, preservation services are essential. To protect digital content against technological obsolescence, data loss, and deterioration over time, digital libraries use a variety of preservation tactics. These strategies include format migration, metadata preservation, data backups, and digital rights management.

#### **User Experience**

User experience services concentrate on enhancing the way users interact with the user interface of a digital library. In order to increase user engagement and happiness, these services strive to offer a user-friendly and intuitive interface, customized suggestions, user feedback systems, and collaborative features. To ensure inclusivity for all users, user experience services also take accessibility into account.

### **Interoperability**

Resource sharing across many platforms and smooth connection with other systems are made possible through interoperability, which is a crucial component of digital library services. To allow interoperability between digital libraries, library management systems, research repositories, and other information systems, interoperability services employ standardized protocols, data formats, and APIs (Application Programming Interfaces).

### **Emerging Technology**

To expand their capabilities, digital library services are progressively integrating emerging technology. Artificial intelligence (AI), machine learning, natural language processing, linked data, and semantic web technologies are some of these technologies. Digital libraries can automate procedures, enhance metadata, increase search accuracy, and offer consumers intelligent services by utilizing these technologies. This thorough analysis intends to investigate the role these essential digital library services play in facilitating efficient information management, access, and retrieval within digital library environments by giving an overview of these services. Each of these services will be discussed in greater detail in the following sections, along with any chances for growth that may exist.

### **Information Provided by Digital Libraries Regarding**

Information services for digital libraries cover a broad range of material that is controlled, arranged, and made available to users inside the context of a digital library. By providing for the various information requirements of users, these services seek to enable the efficient distribution and retrieval of digital materials. The main content categories that are frequently included in information services provided by digital libraries are examined in this section.

### **Textual Resources**

A sizable amount of the information in digital libraries consists of textual resources. These sources cover a wide range of written content, such as books, academic articles, reports, theses, newspapers, periodicals, and literary works. Textual materials may be made available in a variety of forms, such as PDF, HTML, EPUB, or plain text, to suit the preferences and needs of various users.

### **Multimedia Content**

In addition, digital libraries house a wide range of multimedia content, such as pictures, videos, audio files, and animations. These sources encompass a wide range of topics and genres, such as music, documentaries, lectures, and things related to cultural heritage. The breadth and range of the digital library's services are enhanced by multimedia content, which gives users access to interesting and engaging resources.

### **Datasets and Research Outputs**

Scientific data, research outputs, and datasets are frequently included in digital library information services. These resources could include datasets produced by scientific research initiatives, experimental data, survey data, statistical data, and research conclusions. By making these sources accessible through the digital library, scholars can access and reuse data, promoting collaboration and furthering scientific study.

### **Archival Resources**

Archival resources are typically housed in digital libraries, preserving and granting access to important documents, manuscripts, photos, maps, and other primary sources. Research and the

examination of various historical viewpoints are made easier by the insights provided by archival content into past events, societies, and traditions.

### **Educational Resources**

Course materials, lecture notes, textbooks, instructional films, and learning objects are all frequently included in digital library information services. With a focus on students, educators, and lifelong learners looking to advance their knowledge and abilities in a variety of subject areas, these resources promote both official and informal education.

### **Content of the Institutional Repository**

Institutional repositories, which house and display the intellectual output of educational institutions, research organizations, and cultural institutions, are included in many digital libraries. Academic articles, preprints, conference papers, dissertations, theses, technical reports, and other academic works created by the institution's members may be included in institutional repository material.

### **Collections with a Focus**

Informational services provided by digital libraries may include specialized collections that are centered on certain fields, communities, or themes. Resources from fields including medicine, law, engineering, the social sciences, the humanities, or particular cultural or geographical settings may be included in these collections. Specific user groups or research communities can access specialized collections for their particular information needs. Digital library information services seek to offer a complete and multidisciplinary collection of resources by combining these many forms of material.

This makes it possible for users to access a variety of knowledge and information, promoting study, education, and exploration within the context of a digital library. The administration, discovery, and access facets of digital library information services will be further examined in the following sections of this assessment, along with the potential and problems unique to each element.

### **Several Issues that Digital Library Information Services Should Address Include**

Information services provided by digital libraries are essential in resolving a variety of issues and challenges in the field of information management and distribution. These businesses seek to offer practical answers by utilizing cutting-edge methods and technology. We examine a number of issues that digital library information services should work to address in this section:

#### **Accessibility and Inclusivity**

Ensuring that digital library resources are available to all users, especially those with impairments or limited technical access, is one of the major issues. To ensure equal access to information for various user groups, digital library information services should prioritize applying accessibility standards, offering other formats, and integrating assistive technologies.

#### **Overload of Information and Discovery**

Due to the abundance of digital content, consumers frequently experience information overload and difficulty discovering pertinent resources. By providing sophisticated search tools, individualized suggestions, and user-friendly browsing interfaces, digital library information services should address this issue. The most pertinent and useful information can be found and accessed with the help of these features.

### **Quality and Interoperability of Metadata**

Metadata is required for effective resource discovery and management. However, metadata inconsistencies, errors, and a lack of compatibility offer substantial obstacles. Standardized metadata formats, regulated vocabularies, and data integration approaches should be used to improve metadata quality in digital library information services. It is critical for seamless information sharing to ensure interoperability between different systems and platforms.

### **Copyright Protection and Licensing**

The intricacies of copyright compliance and licensing regulations must be navigated by digital libraries. A significant concern is ensuring that digital resources are used in conformity with copyright rules. To preserve the intellectual property of content creators while allowing legitimate access to resources, digital library information services should include procedures for managing copyright information, offering clear usage rights, and establishing access controls.

### **Long-Term Preservation and Sustainability**

Digital libraries are concerned with preserving digital resources for long-term access. The lifespan of digital content is jeopardized by technological obsolescence, data degradation, and shifting formats. To maintain the lifespan and integrity of digital materials, digital library information services should incorporate robust preservation measures such as format migration, digital archiving, and metadata preservation.

### **User Participation and Collaboration**

Digital libraries must encourage user participation and facilitate user collaboration. To foster knowledge exchange, community engagement, and scholarly collaboration, digital library information services should include interactive elements, social sharing capabilities, and collaborative tools. These services contribute to the development of a strong and engaged user community within the digital library ecosystem.

### **Multilingual and Multicultural Assistance**

Digital libraries serve a wide range of user communities with varying linguistic and cultural origins. It is difficult to provide support for multilingual material and cultural diversity. Multilingual interfaces, translation services, and cultural adaptations should be prioritized in digital library information services to ensure that users may access and engage with materials in their chosen languages and cultural contexts. Digital library information services can improve information access, resource discovery, user engagement, and overall user experience by solving these issues. These services help to enhance research, education, and cultural preservation, making digital libraries more useful and valuable in the digital age.

### **Conclusion**

We investigated the various features of digital library information services in this comprehensive analysis, evaluating their relevance, problems, and potential. In the digital age, digital libraries have transformed the way information is maintained, accessed, and shared. They offer a wide range of resources, including textual materials, multimedia content, databases, and historical materials, to meet users' different information demands. Metadata management, resource discovery, access control, preservation, user experience, interoperability, and the incorporation of developing technologies are all key components of digital library information services. These services address a variety of information management issues, such as information overload, resource discovery, copyright compliance, preservation, and user engagement. Digital library information services attempt to provide effective answers to these difficulties by employing sophisticated technologies, standardized protocols, and new techniques. They improve resource

discoverability, maintain compliance with copyright regulations, preserve digital content for long-term access, encourage user participation and collaboration, and support multilingual and multicultural access. The examination of digital library information services emphasizes continual attempts to improve accessibility, usability, and usefulness within the digital library environment. It emphasizes the importance of solid metadata management, smooth interchange, user-centric design, and long-term preservation practices. It also highlights the importance of digital libraries in fostering research, education, cultural preservation, and societal progress. As digital libraries evolve, it is critical to handle lingering difficulties while also exploring new options for innovation. In the future, artificial intelligence, machine learning, linked data, and semantic web technologies may be used to improve the capabilities of digital library information services. Furthermore, addressing concerns of inclusion, equal access, and the digital divide will be critical in ensuring that digital libraries meet the requirements of all user communities. This comprehensive analysis is a helpful resource for researchers, practitioners, and policymakers interested in learning about the challenges and potentials of digital library information services. This assessment contributes to the continuing discussion about information management in the digital era by throwing light on the current state of digital libraries and highlighting opportunities for future growth. Overall, digital library information services have a significant impact on the future of information access, discovery, and dissemination. Digital libraries have the ability to redefine how knowledge is accessed, shared, and conserved, empowering users and facilitating intellectual growth in a quickly changing digital context.

## References

- [1] Agosti, M., & Ferro, N. (Eds.). (2016). *Research and Advanced Technology for Digital Libraries: 20th International Conference on Theory and Practice of Digital Libraries, TPDL 2016, Hannover, Germany, September 5-9, 2016, Proceedings*. Springer.
- [2] Borgman, C. L. (2015). *Big Data, Little Data, No Data: Scholarship in the Networked World*. MIT Press.
- [3] Chowdhury, G. G. (2010). *Introduction to Digital Libraries*. Facet Publishing.
- [4] Committee on a Framework for Developing a New Taxonomy of Disease, Board on Life Sciences, & National Research Council. (2011). *Toward Precision Medicine: Building a Knowledge Network for Biomedical Research and a New Taxonomy of Disease*. National Academies Press.
- [5] Dempsey, L., Malpas, C., & Lavoie, B. (2013). *Collection Directions: The Evolution of Library Collections and Collecting*. Council on Library and Information Resources.
- [6] Gobinda, G., & Chowdhury, S. (2010). *Introduction to Digital Libraries: Concepts, Practices and Challenges*. Chandos Publishing.
- [7] Hider, P. (2018). *Information Resource Description: Creating and Managing Metadata*. Facet Publishing.
- [8] Khan, M. A. (2012). Digital Libraries: An Overview. *International Journal of Computer Science and Information Technologies*, 3(2), 2783-2786.
- [9] Lippincott, J. K., & Johnson, C. A. (2017). *Library Information Services: Concepts, Innovations, and Practice*. Facet Publishing.
- [10] Moen, W. E., & Smiraglia, R. P. (Eds.). (2014). *New Directions in Information Organization. Libraries Unlimited*.
- [11] NISO. (2015). *Understanding Metadata*. National Information Standards Organization.
- [12] Saracevic, T. (2010). Digital Library Evaluation: Toward Evolutionary Concepts. *Journal of Documentation*, 66(6), 933-948.
- [13] Suber, P. (2012). *Open Access*. MIT Press.
- [14] Tammaro, A. M., & Salarelli, A. (Eds.). (2014). *Digital Libraries: Knowledge, Information, and Data in an Open Access Society*. Walter de Gruyter.

- [15] Tennant, R. (2001). Digital Libraries: Definitions, Issues, and Challenges. *Journal of Digital Information*, 2(4).
- [16] Theng, Y. L., Foo, S., & Goh, D. (2015). Digital Libraries: Methods and Applications. *CRC Press*.
- [17] Van Moorsel, A. (2016). Information Security Risk Management: *Risks and Solutions*. Springer.
- [18] Walters, T. O. (2011). Acquisitions and Collection Development in the Digital Age. *Chandos Publishing*.
- [19] Xiao, L., & Lu, J. (2013). Digital Library Development: A Case Study of Digital Library at Purdue University. *The Journal of Academic Librarianship*, 39(4), 360-367.
- [20] Xie, I., Jeng, J., & Barton, M. (Eds.). (2015). Digital Libraries: Providing Quality Information: 17th International Conference on Asia-Pacific Digital Libraries, *ICADL 2015, Seoul, Korea, December 9-12, 2015, Proceedings*. Springer.

# Exploring Digital Information Literacy Skills Among Library Users

S. Shamala<sup>1</sup>, Somashekhar<sup>2</sup> and Dr. Vitthal Bagalkoti<sup>3</sup>

<sup>1&2</sup>Research Scholar, <sup>3</sup>Assistant Professor & Library Officer,

<sup>1,2&3</sup>CMR University, Bangalore, Karnataka, India

E-mail: shamalamisc@gmail.com

## Abstract

*The key purpose of this study is to explore digital information literacy skills among library users. It also tries to identify the various types of digital information literacy skills and find constraints affecting the related skills and competencies of library users in their information-seeking practices. This paper aims to explore the role that digital literacy plays in the users' perception of the usefulness and ease of use of digital technologies and consequently their intention to use technology in the information-seeking practices of users. The study aims to identify the need for digital literacy skills and usage of e-resources and the factors that influenced acquiring digital literacy skills. The findings also show that digital literacy directly impacts the use of library resources and services. The libraries need to organize regular workshops or seminars on digital information literacy skills to raise awareness among their users. It also affects users' academic performance. This study aims to focus on the utility and assessment of digital literacy skills.*

**Keywords:** Digital literacy, E-resources, ICT skills, Information literacy.

## Introduction

The whole world is influenced by the digital culture, which will be the next future. Digital literacy, in this changed environment which is moving towards digital economy is the need of the hour. Hence Digital Literacy, which is the extension of information literacy is catching attention. Being digitally aware and using tools which are relevant for daily living has become essential these days. There is no field without a digital role these days. Digital Literacy looks beyond the development of functional IT skills as it describes a set of digital behaviors, practices and identities which involve critical thinking, online safety skills, digital culture, collaboration and creativity, finding information, communication and netiquette, functional skills along with life-long learning, communication, collaboration and social engagement.

## Digital Literacy

Digital literacy plays a crucial role in the management of e-learning, given the widespread adoption of online education by numerous institutions. "In the contemporary era, students need proficiency in information literacy and digital literacy skills not only for academic success but also for their endeavours beyond the educational realm" (Blummer, Barbara; Kenton, Jeffrey M. 2015). Sohala (2015) emphasizes that digital literacy encompasses various skills related to the utilization of digital technology. Proficiency in accessing, assessing, and utilizing information is imperative for lifelong learning and is considered a fundamental necessity for participation in the information society.

Digital literacy refers to an individual's capacity to discover, assess, and convey information through the utilization of typing or digital media platforms. It encompasses a blend of technical and cognitive proficiencies in employing information and communication technologies to generate, assess, and distribute information. Initially centered on digital skills and independent computer use, the evolution of the internet and the prevalence of social media have led to a redirection of some of its emphasis towards mobile devices.

As per the UNESCO Institute for Statistics (2018), digital literacy is defined as the competence to securely and appropriately access, manage, comprehend, integrate, communicate, assess, and generate information using digital technologies, particularly for the purposes of employment, securing decent jobs, and engaging in entrepreneurship. This encompasses a range of competencies commonly denoted as computer literacy, ICT literacy, information literacy, and media literacy.

### **Need and Significance of the Study**

Libraries serve as repositories where information is acquired, processed, stored, and made accessible for use and reuse, contributing to the generation of knowledge. To meet the evolving information needs of users, libraries continually strive to enhance their methods and methodologies. Investigating the information-seeking practices of users aids libraries in formulating policies, acquiring relevant sources, improving services, and adapting to necessary technologies. Given the increasing availability of online information sources, users must develop digital literacy skills to access e-resources, databases, and internet-based materials. The paramount importance of the study lies in cultivating information literate individuals who possess proficiency in various aspects of information use, including identification, location, evaluation, and ethical utilization of information in diverse formats.

Beyond traditional reading and writing skills, individuals should advance their competencies in visual literacy, media literacy, computer literacy, digital literacy, network literacy, and communication skills. Digital literacy, as an encompassing term, encompasses techniques for achieving proficiency in other literacies. The present study aims to assess and emphasize the significance of digital literacy among library users. It explores the users' awareness of essential information, identifies challenges faced during information retrieval, and contributes to improving literacy programs. Ultimately, this study enhances the overall literacy skills of students and library professionals, facilitating knowledge enhancement through optimal utilization of library resources and services.

### **Need of Upgrading Digital Literacy Skills to Users**

1. Understanding various E-learning platforms like MOOCs, Swayam, Swayam Prabha, NPTEL, etc., becomes crucial in the educational landscape. Massive Open Online Courses (MOOCs) play a pivotal role in facilitating open access to learning resources, offering valuable opportunities for professional development and continuous learning. This accessibility proves particularly beneficial for university lecturers, especially those in developing countries, as they can harness the potential of MOOCs to acquire essential skills and enhance their expertise.
2. Shodhganga, E-Shodhsindhu, National Digital Library, N-LIST Consortium has benefited the library users to learn and enhance their knowledge.
3. The rising prevalence of social networking platforms such as Facebook, Twitter, Instagram, WhatsApp, LinkedIn, YouTube, and Telegram signifies a growing trend in utilizing these platforms for connectivity and communication with others.
4. Digital technology has transformed students into self-centred, inquiry-based, problem-solving individuals, fostering a proactive learning environment through the application of digital literacy skills. Acquiring digital literacy is crucial for success in both personal and professional aspects of life.
5. In the digital realm, individuals have the chance to discover their own expertise outside traditional classrooms. Digital resources operate asynchronously, allowing learners to access them at any time, not restricted to classroom hours.



## Objectives of the Study

The following are the objectives of this study.

1. Identify the essential digital literacy skills needed by users.
2. Explore the significance of digital literacy skills in the contemporary era.
3. Examine the impact of digital literacy skills on students' academic performance.
4. Identify challenges associated with acquiring digital literacy skills for effective learning.
5. Assess the level of ICT skills acquired by users.
6. Investigate factors influencing the utilization of e-resources.

## Digital Information Literacy Skills

Digital information literacy skills are.

### 1. Basic Computer Skills:

Ability to use of computer programs, open a document, create a folder save a file in a folder rename a file/ a folder and delete a file in a folder ,use “Save as” to change file name, location, and/or file type use various print-out options.

### 2. Basic E-mailing skills:

Ability to write an email message send an email, reply to an email, ability to forward an email and send a file as an attachment to an outgoing message.

### 3. Internet Skills:

a. Ability to open an Internet browser (Chrome, Internet Explorer, etc.)

b. Open a new tab in my browser, go to the previous page when browsing on the internet use the refresh function, bookmark a website.

c. Copy-paste information that was found on online and download/save document online.

d. To find sources using Google Scholar, to use Google Scholar’s advanced search option.

e. Searching library online databases,

f. How to use online library catalogue

g. Browsing, searching and filtering data, information and digital content, evaluating data, information and digital content, managing data, information and digital content (UNESCO Law *et al.*, 2018).

4. The capacity to find, evaluates, manage, curate, organize and share digital information.

5. The capacity to design and/or create new digital artefacts and materials such as digital writing; digital imaging; digital audio and video, digital code, apps and interfaces, web pages.

6. Interacting through digital technologies: The capacity to communicate effectively in digital media and spaces such as text-based forums, online video and audio, and social media; to design digital communications for different purposes and audiences.

## Important Aspects of Digital Information Literacy Needed for Library Users

1. *Information Research and Retrieval:* Users need to effectively access information through libraries, the internet, and professional organization databases and search engines. Efficient research and retrieval skills are essential.
2. *Information Validation:* It involves making informed judgments about the quality, relevance, timeliness, completeness, truthfulness, independence, usefulness, and efficiency of digital information sources.
3. *Learning Resources:* Utilizing digital resources from university and college libraries, administrators, academic vendors, and textbook publishers is vital for enhancing the learning experience.

4. *Using Applications:* Users should employ application and utility software, along with internet technology, for tasks such as calculation, storage, updating, retrieval, and data display.
5. *Information Communication:* Presenting digital information in a comprehensible format using word processors, spreadsheets, statistical packages, presentation software, publishing software, and graphic and animation presentation tools.
6. *Social Responsibility:* Understanding the ethical and social consequences of actions and using digital technology and information responsibly and ethically.
7. *Legal Aspects of Digital Information:* Ensuring compliance with relevant laws and regulations concerning access to, use of, and distribution of digital information.
8. *Computer Hardware and Software Selection:* Determining user computer needs and selecting appropriate hardware and software configurations.
9. *Application Development:* Involves developing, testing, and maintaining application programs for broader usage.
10. *System Programming:* Installing and maintaining operating systems and utility software that enable users to utilize computer hardware effectively.
11. *System, Data, and Information Security:* Protecting data and information systems from unauthorized access, destruction, alteration, and fictitious creation.
12. *Personal, Financial, and Identity Security:* Guarding against digital fraud, including identity theft, impersonation, and protecting personal and financial information during e-commerce transactions.
13. *Database Administration:* Involves installing, updating, documenting, and optimizing the performance of database management systems (DBMS), along with instructing users in their proper use.
14. *Media Library Functions:* Preparing, inventorying, storing, backing up, and making available physical storage devices for digital programs and files.
15. *Networking Technology:* Possessing technical competence in configuring, managing, and securing internal and external data networks.
16. *Digital Video & Photography:* Selecting and using appropriate digital photographic devices, formats, and features to meet user needs.

### **Literature Review**

The literature on surveys about the digital literacy skills, Information literacy skills, Government Academic College library facilities, user behaviour and impact of ICT on library resources and services. Many studies have been conducted to investigate the digital literacy skills, information literacy skills and information-seeking practices of library users based on their subject interest, occupation, information environment, and geographical location.

Dadaczynski, K., Okan, O. Messer, M., Leung, A. Y., Rosário, R., Darlington, E., & Rathmann, K. (2021). Digital health literacy and web-based information-seeking behaviour of university students in Germany during the COVID-19 pandemic: cross-sectional survey study. This article discusses the impact of digital literacy on information seeking behaviour. The level of digital health literacy in relation to dealing with web-based COVID-19-related information was high. However, a significant proportion of university students still face difficulties with certain abilities to deal with information, such as finding the right information and evaluating its reliability. There is a need to strengthen the digital health literacy capacities of university students.

Hiremath Shivaleela S (2020): This paper conducts an analytical study on Digital Literacy Skills Among Librarians of First Grade Colleges affiliated to Rani Channamma University Belagavi. This study discusses the Digital Literacy which is beyond the development of functional 7 IT skills, digital behaviours, practices and identities which involve critical thinking, online safety skills, digital culture, collaboration and creativity, finding information, communication and netiquette, functional skills along with life-long learning, communication, collaboration and social engagement issues.

Mahadik, Ashwini Pandurang (2019): Digital literacy among users in law institute libraries in Pune a study. This study describes the growth and development of law education and law institutes in Pune. The studies highlighted the awareness of users about facilities available in law libraries and assess its utility by them in law institute libraries of Pune.

Smt. Jayashree Basavaraj Nandi (2021): Information Seeking Behaviour of Users of Library in Digital Environment: A Study of North Karnataka Engineering Colleges. This study finds out the information needs and gathering habits of users of engineering college libraries in digital environment of north Karnataka. The study also examines the awareness, extent of use of e-resources and searching techniques used for accessing required information by the users of the library.

Sharaddha Kalla (2021): A Study of digital environment information seeking behaviour of users of Iihmr University. This study is related to the Information seeking behaviour, accessible information centres and IIHMR University Users. The research study endeavours to identify the most important resource desired by the data user to accumulate data information on these lines and in addition to know the status of data information available in the digital library data resources, fundamental infrastructure of library and to examine the sufficiency of the digital library's data resources, need of the fulfilment of digital library services which are now a days provided to ascertain modifications and additions accordingly.

### **Suggestions**

1. This study suggests that digital literacy skills have influence on their MOOC participation.
2. Lack of digital literacy skills is the main reason for poor utilization of library e-resources and services. So, Libraries need to be engaged in literacy programs and trainings in collaboration with the communities.
3. Library users need to be both information and digital literate in order to have the ability to locate, evaluate and adequately make use of needed information.
4. Libraries need to organize regular workshops or seminars to raise awareness among their users on importance of digital literacies and should hire more ICT inclined and digital literate librarians to anchor these workshops.

5. The librarians also should recommend to the management to increase budget of the libraries to provide quality electronic resources to its users. Libraries should think of investing in new technological infrastructure so that they can serve users on online setup.
6. The workshop should be designed to teach relevant information literacy skills in a computer lab like hands on training.
7. Teaching of digital information literacy skills should be made essential and feasible,
8. Digital literacy should be given to enhance the academic quality of students' work.

### Conclusion

In conclusion, digital literacy emerges as an essential skill set for both librarians and library users, playing a pivotal role in the optimal functioning and success of libraries in the digital era. The absence of digital literacy can lead to detrimental consequences for both libraries and their users. In order for libraries to stay relevant, operate efficiently, and keep pace with the evolving landscape, a primary focus should be placed on cultivating digital literacy among both library staff and users. Digital literacy, within this context, encompasses not only technical ICT skills required for internet use but also critical thinking in the selection, access, and utilization of information. Librarians play a crucial role in this regard, actively acquiring the latest information technology and content to ensure they can effectively meet the diverse information needs of users. By prioritizing digital literacy, libraries position themselves to adapt, thrive, and continue serving as valuable resources in an increasingly digitalized world.

### References

- [1] Biradar, K., & Naik, K. J. (2017). Digital literacy skills and competencies among the research scholars and PG students of deemed university libraries, Bangalore: a Study. *Journal of Advances in Library and Information Science*, 3(6), 252-257.
- [2] Clark, L., & Visser, M. (2011). Digital literacy takes center stage. *Library Technology Reports*, 47(6), 38-42.
- [3] Dadaczynski, K., Okan, O., Messer, M., Leung, A. Y., Rosário, R., Darlington, E., & Rathmann, K. (2021). Digital health literacy and web-based information-seeking behaviours of university students in Germany during the COVID-19 pandemic: cross-sectional survey study. *Journal of medical Internet research*, 23(1), e24097.
- [4] Hiremath Shivaleela S (2020) Digital Literacy Skills Among Librarians of First Grade Colleges Affiliated to Rani Channamma University Belagavi An Analytical Study. <http://hdl.handle.net/10603/447377>, <https://shodhganga.inflibnet.ac.in:8443/jspui/handle/10603/447377>.
- [5] Huerta, E., & Sandoval-Almazán, R. (2007). Digital literacy: Problems faced by tele-center users in Mexico. *Information Technology for development*, 13(3), 217-232.
- [6] Kelly Patricia Kingrey, Concepts of Information Seeking and their Presence in the Practical Library Literature.(2015), *Library Philosophy and Practice*, Vol. 4 No. 2
- [7] Kenton, J., & Blummer, B. (2010). Promoting digital literacy skills: Examples from the literature and implications for academic librarians. *Community & Junior College Libraries*, 16(2), 84-99.
- [8] Mahadik, Ashwini Pandurang (2019) Digital literacy among users in law institute libraries in Pune a study. <http://hdl.handle.net/10603/286557>, <https://shodhganga.inflibnet.ac.in/handle/10603/286557>.
- [9] Ms. Jovita Lobo and Dr. Keshav Ramesh Dhuri 1 Positive Impact of Covid-19 Pandemic in Enhancing Digital Literacy Skills among Library Professionals: A Study.
- [10] Odu, A., & Omosigho, N. A. (2017). Digital literacy and the implication on Nigerian digital library. *Journal of Business Education*, 3, 13-19.

- [11] SharddhaKalla (2021): A Study of digital environment information seeking behaviour of users of lihmr University.
- [12] Smt. Jayashree Basavaraj Nandi (2021) Information Seeking Behaviour of Users of Library in Digital Environment a Study of North Karnataka Engineering Colleges. <https://shodhganga.inflibnet.ac.in/>.
- [13] Turamari, R. & Kotur, M. B. (2020). Changing Skills of LIS professionals in the Digital Environment. *Indian Journal of Library and Information Technology*, 10(04), 34-38.

# Digital Preservation of Knowledge: Issues and Challenges

Sakhawat Hussain<sup>1</sup> and Dr. Rajesh Kumar<sup>2</sup>

<sup>1</sup>Research Scholar, <sup>2</sup>Assistant Professor,  
<sup>1&2</sup>Mangalayatan University, Aligarh, Uttar Pradesh, India  
E-mail: sakhawathuss@gmail.com, drrajeshkdiwakar@gmail.com

## Abstract

*The article discusses the problems and difficulties related to knowledge preservation in the digital age. With society depending more and more on digital platforms, information preservation becomes essential. The main themes include dealing with format obsolescence, ethical issues, integrating technical advancement, digital legacy, internal & external attack and the necessity of cooperation among various parties.*

**Keywords:** Knowledge management, Digital preservation, Digital preservation standards, Digital preservation errors

## Introduction

With the rapid growth of technology and the widespread migration to digital information storage, digital preservation of knowledge is an essential endeavour. The preservation of digital content becomes critical as societies depend more and more on digital platforms for information distribution, education, and communication. In order to maintain digital resources' usefulness and accessibility throughout time, this method entails protecting documents, photos, and multimedia.

Effective digital preservation, however, requires addressing a number of issues, such as media fragility, legal complications, technology obsolescence, financial limits, and the requirement for collaboration and standardization. The framework for a thorough examination of the problems pertaining to the conservation of our digital legacy and the tactics needed to preserve knowledge for future generations is established by this introduction.

Knowledge is defined as

1. Knowledge and abilities obtained by education or experience, the conceptual or applied comprehension of a subject.
2. What is known overall or in a specific field, data and facts?
3. knowledge or familiarity acquired via firsthand observation of an actual occurrence, event, or circumstance.

## Knowledge Management

Knowledge management is the "judicious application of expertise." An increasing number of tasks in the information economy require "think work." Sorting through information to determine what is significant and what is not requires thinking. As a result, "think work" is a subset of "knowledge work," more precisely the information processing portion; "informed action" is the other portion. Programs for knowledge management are often linked to organizational goals including as.,

1. Performance Improvement
2. Viable innovation
3. Transfer of lessons learnt (for example between projects); and
4. Development of collaborative processes

## Data, Information and Knowledge

It is possible to distinction between data, information and knowledge:

1. Data consists of the basic facts- the building blocks-for information and knowledge.
2. Information is simply data that has been interpreted so that it makes sense to specific people. Anyone who is allowed access to it can obtain it.
3. As Drucker (1988) wrote, 'information is data endowed with meaning and purpose'.
4. Knowledge is the application of information for a purpose.
5. It is difficult to pin down, encode, and distribute as it is elusive, personal, and frequently intangible.

### **Explicit and Tacit Knowledge**

Nonaka (1991) and Nonaka and Takeuchi (1995) stated that knowledge is either explicit or tacit. Explicit knowledge can be modified. It is stored in databases, company intranets, and intellectual property portfolios, where it is accessible and recorded. Tacit knowledge exists in people's thoughts. Acquired from firsthand experience, it is challenging to express in written form. As suggested by Hansen *et al.*, (1999), it consists of operational skills, industry insights, commercial judgment, and scientific or technological know-how. How to transform implicit knowledge into explicit knowledge is the primary difficulty in knowledge management.

### **Digital Preservation**

The act of ensuring that digital information of lasting worth is still accessible and usable is known as digital preservation. It covers different planning, resource distribution, and technology and preservation technique application. Finally, it wraps up different kinds of policies, strategies, and their actions to guarantee access to reformatted and born-digital information. ALA (2007) these definitions have been developed "To promote an understanding of digital preservation within the library community, as well as our allied professions and the user communities we exist to serve. This draft is presented to mark our current understanding of digital preservation and encourage further development of these ideas".

### **Various Steps of Digital Preservation**

First and foremost, planning is the most important step in the digital preservation process. It's crucial to plan ahead for the following issues:

1. What content has to be kept safe,
2. how long must it be kept safe,
3. Future access and usage instructions for the conserved digital content
4. By whom will the content be accessed?

### **Issues for Digital Preservation of Knowledge**

1. *Media Failure*: It is necessary to anticipate that all storage media will deteriorate over time, leading to irreversible bit mistakes, and that they may suddenly and catastrophically lose large amounts of data irreversibly due to disk crashes or lost off-line media.
2. *Hardware Failure*: It is necessary to anticipate that all hardware components may experience both catastrophic irreversible failures, like burned-out power supply, and temporary recoverable failures, like power outages.
3. *Software Failure*: One must assume that all software will occasionally have vulnerabilities that could endanger the data that has been stored.
4. *Communication Errors*: Systems are not allowed to rely on the success or failure of the network transfers they utilize to ingest or distribute content within a given time frame, or on the content being delivered intact.

5. *Failure of Network Services*: It is imperative for systems to consider the possibility of both temporary and permanent failures affecting both the network services and individual entries within the external network services they utilize, such as resolvers for domain names and persistent URLs. A persistent URL will not resolve if the resolver service does not take the same care to preserve its data as the digital preservation service, and domain names will disappear or be transferred if the registrant does not pay the registrar.
6. *Media and Hardware Obsolescence*: There will eventually be hardware and media component failures. They might be replaced before then if they have a long history of remaining theoretically readable—that is, if someone could find them a suitable reader—or they might become obsolete in the sense that they can no longer communicate with other system components.
7. *Software Obsolescence*: Software elements also have an expiration date. When information cannot be decoded from a storage format into a readable form, it typically shows up as format obsolescence even though the bits in which the data was stored are still available.
8. *Operator Error*: Both recoverable and irrecoverable faults in operator activities must be anticipated. This covers the digital preservation program itself as well as the operating system it runs on, the other apps that share the same environment, the hardware that supports them, and the network that allows them to connect.
9. *Natural Disaster*: It is necessary to prepare for natural calamities like fire, flood, and earthquake.
10. *External Attack*: There is no reason to believe that digital libraries and archives will be immune to hostile attacks, just as paper libraries and archives are. Every system linked to an open network is susceptible to worms and viruses. Systems for digital preservation need to be totally separated from outside networks or defended against the inevitable threats.
11. *Internal Attack*: Insiders, or anyone with authorized access to the system, are often the ones abusing computer systems. A digital preservation system needs to be prepared for insider misuse even in the event that it is totally cut off from outside networks.
12. *Economic Failure*: Compared to information on paper, digital information is far more susceptible to disruptions in the money supply. Power, cooling, bandwidth, system management, domain registration, and other expenses are continuous. It is necessary to anticipate that funding for digital preservation may fluctuate over time, perhaps even going completely away.
13. *Organizational Failure*: The organization in which digital preservation is entrenched, as well as the technology itself, must be considered in the system view of digital preservation. These groups might cease to exist, possibly due to insolvency or a shift in their goals. This might take away the support that digital preservation technology needs to continue existing.

### **Challenges for Digital Preservation of Knowledge**

The challenges associated with digital preservation are fundamentally different from those associated with the preservation of traditional format resources. Planning, resource allocation, and the implementation of preservation techniques and technologies are a few of these areas that are required to guarantee the continued accessibility and usability of digital material of continuing value. The difficulties are as follows.



### *1. Durability*

The majority of digital content only exists in encoded form, requiring specialized software to handle, which presents a variety of difficult and connected issues about its durability. Hardware and software components that are digital in nature frequently undergo version or processing capability changes. Non-technical components of the issue include management, funding, staffing, upkeep of digital records, and the necessity for well-planned policy updates and standard approaches and practices to prevent the loss of digital information.

### *2. Form of Material*

Comparing digital resources to traditional formats, the former have a far shorter lifespan. Given that they are useable media in this scenario, magnetic and optical media vary qualitatively.

### *3. Media Problem*

Media obsolescence is a typical occurrence due to advancements in the computer hardware, software, and storage industry. Eight-inch floppy disks, tape cartridges and reels, hard-sectored disks, and seven-track tapes are a few examples of devices with a short lifespan. CD-ROM/DVD-ROM and optical WORM are more resilient storage media than those inaccessible storage technologies.

### *4. Software Dependent Problem*

For digital documents to be relevant and accessible, application software is typically required. The issue, though, is that software is likewise evolving and changing through version changes. Different software requires different types of encoding, so in order to activate digital documents on a computer, certain software needs to be installed. The only way to interpret a bit stream is to run the program that generated it or a closely related program that can understand it.

### *5. Standards*

Problems arise when there are no established procedures, standards, or techniques for protecting digital information. Difficult to choose the standards. For different work different standards are available, which are

a) Few standards for architecture are:

- i. ISO/DIS 15489 (Draft International Standard)
- ii. AS 4390 (Australian Standard)
- iii. DoD 5015.2-STD (Its similar as ISO/DIS 15489 or AS 4390)
- iv. IAIS (Open Archival Information System)

b) Few standards for preservation of contents

- i. PDF (Portable Document Format)
- ii. XML (Extensible Markup Language)

c) Few standards for Preservation Access

- i. Dublin Core
- ii. MARC (Machine Readable Catalogue)
- iii. ISAD (G) (General International Standard Archival Description)
- iv. Z39.50

d) Few standards for Interoperability

- i. ODMA (Open Document Management API)
- ii. DMA (Document Management Alliance)
- iii. WebDAV (World Wide Web Distributed Authoring and Versioning)

### *6. Intellectual Property Rights (IPR)*

Digital document preservation is severely hampered by intellectual property rights (IPR). Complex techniques are used in digitization to address the legal and practical issues surrounding the migration of intellectual property, involving creators, owners, managers of digital archives, and prospective consumers.

### *7. Rapid Growth and Evolution*

The wide range of formats and distribution methods are made possible by rapidly evolving technology. It can be difficult to set up a program that adapts to changes.

### *8. Sustainability*

Everyone agrees that inexpensive programs and efficient cost models are essential. The commitment level determines the scale. The program ought to consider realistic expectations for the necessary resources; in other words, the libraries shouldn't make promises they can't keep.

### *9. Content Provider Partnerships*

Future preservation will be made easier by collaborating with producers and suppliers of valuable content to include the necessary clauses before deposit.

### *10. Enabling Full Preservation*

It takes sustained institutional effort, the creation of partnerships, and financial support to transition from well-managed digital collections to properly preserved resources in the real meaning of the word.

### *11. Flexibility*

The specification of the dissemination information package (DIP), which will enable the release of information to an increasing number of content delivery platforms, must be continuously revised by the digital archive in response to changing user expectations and improving technological capabilities.

### *12. Education*

All staff members will receive training and knowledge since they support the digital preservation function both directly and indirectly, even though majority do not have digital preservation as one of their primary tasks. The Libraries is dedicated to educating its internal staff as well as the larger community of digital material creators, archivists, and users about concerns and advancements in digital preservation through proper training.

## **Conclusion**

In conclusion, there are a number of serious issues with digital information preservation that need for all-encompassing fixes. A diverse strategy is required due to many factors such as the issue of format obsolescence and the intricacies involved in addressing ethical considerations. The formulation of strong legislation, innovation in technology, and cooperation amongst various stakeholders are necessary elements. In the face of the rapidly changing landscape of digital information, it is critical to give diversity, accessibility, and ethical standards first priority. Overcoming these obstacles could have a huge impact on the preservation of our cultural and historical legacy as well as the accessibility of knowledge on a global scale. Developing sustainable and scalable policies will require governments, academics, industry, and the general public to embrace a common responsibility. Despite these obstacles, effective digital preservation promises to cross geographical and temporal borders and guarantee that the treasure of human knowledge will be preserved for future generations.

## References

- [1] Awamleh, M. A., & Hamad, F. (2022). Digital Preservation of Information Sources at Academic Libraries in Jordan: An Employee's Perspective. *Library Management*, 43(1–2), 172–191. <https://doi.org/10.1108/LM-10-2021-0088>
- [2] Hazarika, R., & Librarian, A. (2020). Digital Preservation in Academic Libraries. *International Journal of Library and Information Studies*, 10(2), 2231–4911. <http://www.ijlis.org>.
- [3] IGNOU. (N.D.). Knowledge Management. In *Egyankosh, IGNOU: Vol. Unit 2* (Pp. 26–39).
- [4] Oluwaseun, A.-F., Ottong, E. J., & Ottong, U. J. (2018). Preservation of Library Resources in Nigeria Universities: A Study of Collections in Cross River State Universities. *Communications of the IIMA*, 15(3). <https://doi.org/10.58729/1941-6687.1391>
- [5] Parmar, R. D., & Pravin Rawat, U. (2021). Digital Preservation of Library Resources: Strategic Planning A Digital Preservation of Library Resources: Strategic Planning A Management Perspective Management Perspective. *Library Philosophy and Practice (E-Journal)*. <https://digitalcommons.unl.edu/libphilprac>
- [6] Roopa Gokhale-Shahade. (2018). Trends in Digitization and Archiving, Digital Preservation: Issues and Challenges. *Journal of Emerging Technologies and Innovative Research (JETIR)*, 5(10), 197–203. <http://nationalarchives.nic.in>
- [7] Sokoh, G. C., & Okolie, U. C. (2021). Knowledge Management and Its Importance in Modern Organizations. *Journal of Public Administration, Finance and Law*, 20. <https://doi.org/10.47743/jopaf-2021-20-19>.

# Knowledge Sharing and Dissemination in Educational Institutions: Practices and Comparative Insights Between Public and Private Sectors

**Dr. Sharon Valarmathi**

Associate Professor, Christ University, Bengaluru, Karnataka, India

E-mail: valarmathi.b@christuniversity.in

## Abstract

*Higher education institutions are grappling with challenges amid the advancement of technology. Knowledge management takes centre stage as the primary focus to address information sharing and processing issues. The current study delves into the knowledge-sharing culture among private and public institutions. Three hundred faculty members from higher education institutions provided their responses, revealing a significant difference in knowledge-sharing culture between private and public institutions. The institutional culture is more readily absorbed in private institutions due to faculty members' opportunities to disseminate their learning in various forums.*

**Keywords:** Knowledge management, Knowledge sharing, Higher educational institutions, Culture, Knowledge economy.

## Introduction

Contemporary Higher Educational Institutions (HEIs) are facing unprecedented challenges, particularly in Indian universities. Despite extensive research aimed at improving India's education system, the focus has shifted towards reshaping the practices of academicians in teaching, research, and work within Higher Education. The relevance of Higher Education has come under scrutiny, prompting a departure from conducting research for its own sake.

Additionally, questions arise regarding the societal contributions made by HEIs, particularly during economic crises. The 21st-century developments have posed additional challenges in the knowledge economy, with globalisation and technological advancements (Yeboah, 2023). Higher educational institutions are responsible for managing and disseminating knowledge frameworks within their institutions.

Knowledge should be strategically utilised in the technological landscape to gain a competitive edge and significantly change the knowledge management system. This revolution will empower institutions, making them more formidable compared to their counterparts. Notably, the ability to learn faster than competitors is recognised as a pivotal source of competitive advantage (Zheng, 2017). Both practitioners and researchers assert that knowledge management holds substantial influence within any organisational setup, significantly impacting performance and ensuring survival in dynamic environments (Islam *et al.*, 2021; Asrar-Ul-Hag *et al.*, 2016).

Despite the critical role of knowledge management in higher education for performance measurement and quality enhancement, there exists a notable scarcity of research on these interconnected concepts. While businesses and service sectors heavily rely on knowledge management, Higher Educational Institutions (HEIs) have unfortunately neglected its significance. In the information era, effective knowledge management in higher education emerges as a defining element for an institution's competitiveness, growth, and sustainability. The success of any institution is intricately linked to the availability and efficient utilisation of its intangible assets, with knowledge being the primary driver.

According to Nonaka (1994), knowledge is the essential economic resource that enables organisations to thrive in a competitive environment by efficiently utilising knowledge creation, inventory, and diffusion. Edvinson and Malone (1997) posit that intangible assets have become more crucial to organisational success than traditional factors of production such as land, labour, machine, and capital. Although the significance of these traditional factors persists, they have assumed a secondary role in wealth creation, particularly in knowledge-based economies. To embrace Knowledge Management (KM), institutions must cultivate a culture that encompasses unique beliefs, values, norms, and behaviour.

### **Review of Literature**

Research studies by Alpana Trehan and Pooja S. Kushwaha (2012) and Mamta Bhusry and Jayanti Rajan (2011) delve into the implementation and collaboration aspects of knowledge management (KM) in Indian B-schools and higher educational institutions (HEIs), respectively. These studies illuminate frameworks and solutions designed to optimise KM capabilities and address challenges in HEIs, including insufficient emphasis on research and consultancy, deficient institutional planning, weak IT infrastructure, and sluggish innovation in learning. Examining knowledge sharing and dissemination dynamics in educational institutions, Dr. JC Henning (2003) underscores the significance of library consortia for collaborative idea exchange among academic libraries.

Furthermore, the use of technology for knowledge exchange, enhancing teaching, learning, and research, is highlighted in studies by Arumugam Rathinavelu (2005) and A.F. McCarthy (2006). Additionally, Siranjuddin Suhaimee *et al.*, (2006) focus on cultivating a knowledge-sharing culture in Malaysian public higher education institutions, while Po-Ying Chu *et al.*, (2007) explore the impact of a Knowledge Management System (DKMS) on design education, revealing heightened learning and satisfaction among students. These studies underscore the pivotal role of technology, collaboration, and organisational culture in fostering effective knowledge-sharing and dissemination practices within educational settings.

Knowledge transfer is the active and relevant utilisation of knowledge within a firm to create value, particularly in products, processes, and services. Knowledge sharing is a voluntary process by individuals, but it must comply with the code of conduct (Zheng, 2017). The ability to locate the right knowledge in the right form is crucial for sustaining competitive advantage. This process involves intentional and unintentional movement of information through mechanisms such as written communications, training, conferences, publications, job rotation, mentoring, and unplanned human interactions like stories, myths, and informal networks.

Knowledge transfer, synonymous with knowledge sharing in some contexts, is here defined as the distribution of knowledge within an institution, occurring between individuals and teams. It involves exchanging ideas, thoughts, and experiences, contributing to task execution in teamwork or through informal conversations. The transfer is successful when individuals willingly assist and learn from others, promoting the development of new skills and competencies.

According to Senge (1990), this process involves digesting, absorbing, and applying knowledge, ultimately redistributing it from areas of high concentration to those in need. In this context, the concept of knowledge dissemination pertains to the respondents' perspectives on the degree to which knowledge is conveyed and exchanged within the institution.

The assessment of knowledge transfer mechanisms involves the use of several statements to gauge the respondents' perceptions regarding processes such as mentorship and channels for knowledge

distribution. The measurement of knowledge transfer is conducted through six distinct items, aiming to capture the extent and effectiveness of mechanisms facilitating the sharing and transmission of knowledge within the institutional framework.

The statements are explained below.

1. *Statement:* New members of staff are assigned to mentors who help them find their way in the organisation.

*Measurement:* This statement measures knowledge sharing through mentorship, emphasising the importance of transferring institutional culture and expertise from experienced staff to new members.

2. *Statement:* Much knowledge is distributed in informal ways, e.g., in the corridors, tea rooms, etc.

*Measurement:* The measurement here focuses on informal communication channels, assessing the extent to which knowledge are shared through casual interactions in common areas, fostering idea generation.

3. *Statement:* Regular meetings are organised at which professional matters are discussed.

*Measurement:* This statement measures knowledge sharing through formalised meetings, providing a structured platform for faculty members to exchange knowledge and thoughts on professional matters.

4. *Statement:* Colleagues inform one another regularly about positive experiences and successful projects undertaken.

*Measurement:* This statement gauges knowledge sharing through the sharing of success stories, acknowledging that the dissemination of experiences and project details contributes to meaningful learning experiences for other staff members.

5. *Statement:* Our peer review system allows opportunities for discussing work methodologies.

*Measurement:* This statement assesses knowledge sharing through a peer review system, emphasising the importance of creating opportunities for faculty members to discuss and exchange insights on work methodologies.

6. *Statement:* Job rotation occurs based on one's know-how, thereby ensuring knowledge distribution.

*Measurement:* The measurement here focuses on job rotation as a means of knowledge distribution, acknowledging that changes in teaching assignments or programs enable staff to acquire new knowledge and skills.

The study collected data from 300 respondents in selected public and private educational institutions. The data were analysed using SPSS, and the required validity and reliability tests were conducted before analysis.

## **Analysis and Discussions**

The current status of knowledge management implementation, as classified by respondents, reveals that 17% report non-existence, 53% are in the initial stage, 20% are in the development stage, and 10% are in the strengthening stage.

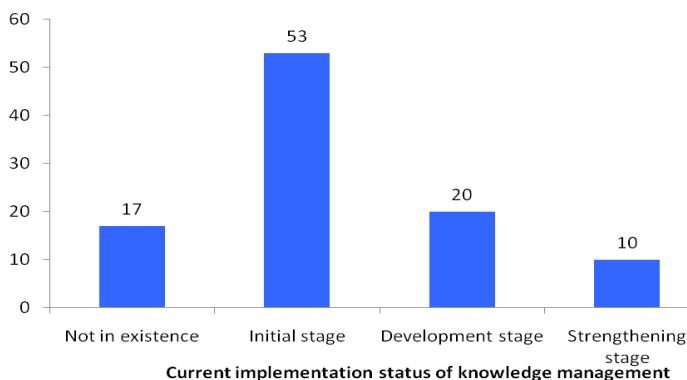

Fig.1 Current implementation status of knowledge management

TABLE I OPINION TOWARDS THE KNOWLEDGE DISSEMINATION/ SHARING

Particulars	SDA		DA		N		A		SA		Total
	N	%	N	%	N	%	N	%	N	%	
New members of staff are assigned to mentors who help them to find their way in the organisation.	38	12.67	107	35.67	79	26	56	18.67	20	6.67	300
Much knowledge is distributed in informal ways, e.g. in the corridors, tea rooms, etc.	50	16.67	112	37.33	88	29	37	12.33	13	5.33	300
Regular meetings are organised, at which professional matters are discussed.	22	7.33	87	29.00	94	31	80	26.67	17	5.67	300
Colleagues inform one another regularly about positive experiences and successful projects undertaken.	44	15.67	133	45.33	69	23	35	11.67	19	6.33	300
Our peer review system allows opportunities for discussing work methodologies	32	10.67	110	36.67	90	30	42	15.00	26	8.67	300
Job rotation occurs, based on one's know-how, thereby ensuring knowledge distribution	20	6.67	70	23.33	92	31	80	26.67	38	12.67	300

Primary source

Opinions toward knowledge dissemination and sharing practices were analysed, highlighting varying degrees of agreement and disagreement among respondents regarding mentorship, informal knowledge sharing, regular meetings, peer review, and job rotation. Most faculty members (35.67%) agree that new members were assigned mentors to understand the institution's culture, while 26% did not agree or disagree with this statement. However, a noteworthy percentage (12.67%) strongly disagrees with this practice, suggesting potential challenges in the on boarding process. Informal knowledge exchange is explored in the second statement, with a

considerable portion (37.33%) expressing disagreement regarding the distribution of knowledge in informal settings. This highlights potential areas for improvement in leveraging informal channels for knowledge transfer. The survey delves into organisational communication practices, revealing that regular professional discussions in meetings are positively perceived by 53.67% (26.67% agree and 26% neutral), but 7.33% express strong disagreement. This suggests a need for further examination of the effectiveness of current meeting structures.

Positive experiences and successful projects are apparently not consistently shared, as 45.33% express disagreement. Encouragingly, 15.67% strongly agree, indicating some success in fostering a culture of sharing accomplishments. The peer review system and opportunities for discussing work methodologies receive a mix of responses, with 36.67% expressing disagreement and 30% remaining neutral. However, 24.67% (15% agree and 8.67% strongly agree) recognise the system's effectiveness in facilitating discussions. Lastly, job rotation based on knowledge is met with varying opinions, with 31% neutral and 23.33% in disagreement. Nevertheless, a noteworthy 39.34% (26.67% agree and 12.67% strongly agree) support the idea, suggesting recognition of the benefits associated with knowledge-based job rotation. The survey indicates diverse opinions regarding knowledge-sharing practices within the organisation, emphasising the need for targeted improvements in certain areas to enhance overall knowledge distribution and collaboration.

TABLE II FRIEDMAN TEST- KNOWLEDGE DISSEMINATION/ SHARING

Particulars	Mean	SD	Mean Rank	Reliability
New members of staff are assigned to mentors who help them to find their way in the organisation.	2.71	1.11	3.40	0.783
Much knowledge is distributed in informal ways, e.g. in the corridors, tea rooms, etc.	2.50	1.05	3.04	
Regular meetings are organised, at which professional matters are discussed.	2.94	1.04	3.86	
Colleagues inform one another regularly about positive experiences and successful projects undertaken.	2.51	1.08	3.01	
Our peer review system allows opportunities for discussing work methodologies	2.73	1.10	3.49	
Job rotation occurs, based on one's know-how, thereby ensuring knowledge distribution	3.15	1.12	5.21	

A Friedman Test was conducted to rank the effectiveness of knowledge dissemination and sharing practices. "Job rotation occurs, based on one's know-how, thereby ensuring knowledge distribution" emerged as the top-ranked practice, followed by "Regular meetings are organised, at which professional matters are discussed," with "Our peer review system allows opportunities for discussing work methodologies" securing the third position. The above results suggest that there is a notable difference in the mean scores related to knowledge dissemination between private and public institutions. Specifically, new staff members in private institutions are assigned mentors for orientation, regular meetings are held for professional discussions, and colleagues regularly share positive experiences and successful projects. Additionally, there is an emphasis on the peer review system for discussing work methodologies. However, in public institutions, the mean score is higher in the context of job rotations based on individual expertise, ensuring effective knowledge distribution.

## Conclusion

The diverse studies on knowledge sharing and dissemination in educational institutions underscore the critical role of effective mechanisms in fostering a culture of continuous learning and collaboration. Driven by the need for successful knowledge management, these studies emphasise



various strategies, including mentorship programs, informal communication channels, formal meetings, success story sharing, peer review systems, and job rotations. The implementation of technology, such as Knowledge Management Systems (KMS) and Information and Communication Technology (ICT), emerges as a common thread across several studies, highlighting its potential to enhance knowledge-sharing practices. The comparison between public and private institutions reveals variations in emphasis, with private institutions focusing on mentorship, regular meetings, and peer review. In contrast, public institutions prioritise job rotations for knowledge distribution. These findings collectively advocate for a holistic approach that integrates formal and informal strategies, leveraging technology and organisational culture to facilitate effective knowledge transfer and dissemination within educational settings.

## References

- [1] Aksu, A., & Bahattin, O. (2005). Individual learning and organisational culture in learning organisations: five-star hotels in Antalya region of Turkey. *Managerial Auditing Journal*, 20(4), 422-41.
- [2] Asrar-Ul-Hag, M., Anwar, S., & Nisar, T. (2016). A systematic review of knowledge management and knowledge sharing: Trends, issues, and challenges. *Cogent Business & Management*, 3(1), 1127744
- [3] Bhusry, M., & Rajan, J. (2011). Knowledge collaboration in higher educational institutions in India: charting a Knowledge Management solution. *International Journal of Computer Science*, 8(5), 332-341.
- [4] Chu, P. Y., Chen, L. C., & Wei, W. L. (2007). A study on the effect of using a knowledge management system on design education. *International Journal of Information Management*.
- [5] Henning, J. C. (2003). Collaboration and sharing of knowledge: The role of consortia. *Proceedings of the International Conference on Collaboration and Sharing of Knowledge 30 & 31 July*.
- [6] Edvinsson, K., & Malone, M. S. (1997). *Intellectual Capital: Realizing Your Company's True Value with the Authors of the New Intellectual Capitalism*. Harper Business.
- [7] Islam, T., Ahmad, S., Kaleem, A., & Mahmood, K. (2020). Abusive supervision and knowledge sharing: Moderating role of Islamic work ethic and learning goal orientation. *Management Decision*, 59(2), 205– 222
- [8] Laoufi, A., Mouhim, S., Megder, E., Cherkaoui, C., & Mammass, D. (2011). Using knowledge management in higher education: research challenges and opportunities. *Journal of Theoretical and Applied Information Technology*, 30th September 2011, Vol. 31 No.2.
- [9] McCarthy, A. F. (2006). Knowledge management: evaluating strategies and processes used in higher education (Ph.D. dissertation). Digital dissertation consortium (3221289).
- [10] Nonaka, I. (1994). A dynamic theory of organisational knowledge creation. *Organization Science*, 5(1), 14-37.
- [11] Suhaimie, S., Baskar, A. Z. A., & Alioas, R. A. (2006). Knowledge Sharing Culture in Malaysian Public Institution of Higher Education: An Overview. *Proceedings of the Postgraduate Annual Research Seminar 2006*, 354-359.
- [12] Trehan, A., & Kushwaha, P. S. (2012). The implementation of knowledge management system in B-Schools. *International Journal of Multidisciplinary Management Studies*, 2(2), 252-260.
- [13] Yeboah, A. (2023). Title of the Article. *Cogent Business & Management*, 10, 2195027. <https://doi.org/10.1080/23311975.2023.2195027>
- [14] Zheng, T. (2017). A Literature Review on Knowledge Sharing. *Journal of Sociology and Anthropology*, 5(3), 31-42. <https://doi.org/10.4236/jss.2017.53006>.

# A Study on Activities and Services of the National Digital Library of India: Perspectives on Digital Libraries

Kakoli Goswami<sup>1</sup> and Pranjit Kalita<sup>2</sup>

<sup>1</sup>Librarian, Ratnapith College, Dhubri, Assam, India

<sup>2</sup>Assistant Librarian, Pub Bongsor College, Pacharia, Assam, India

E-mail: kakoligoswami1@gmail.com, kalitapranjit18@gmail.com

## Abstract

*The National Library of India represents the dreams of Digital India from the eyes of educationist and information scientists to deliver a platform to ease the education strategies towards nation. The study encompasses the activities and services of National Digital Library of India. To reach out every corner of India, to spread the delight of teaching and learning, NDLI make a forward step through the digital platform. This article covers the e-resources NDLI offers to develop the nation.*

**Keywords:** NDLI, digital library, e-resources, nation, India, information, DEEPAK, CHAVI, IDR

## Introduction

Research plays a crucial role in advancing knowledge, solving problems and driving progress in various fields. Research also contributes to the expansion of existing knowledge. Analyzing various aspects of a platform that assures teaching learning in a smooth manner is very important so that it makes awareness among the peoples. Digital literacy is the most important and sensible topic in current situation, after Covid-19 situation digital literacy is leading the path to growth and development. Digital literacy in various ways like digital library, databases, repositories etc. National digital library of India is the leading institution in case of providing a space suitable for teaching learning experience.

## Digital Library

A digital library is also known as Internet library, online library, digital repository, a library without walls or a digital collection of digital resources including images, texts, audio, video and other multimedia. So in general objects that are accessed through internet can be called digital objects and a digital library consists of various kinds of digital objects.

## National Digital Library of India

National Digital Library of India (NDLI) is a virtual repository of learning resources which is not just a repository with search/browse facilities but provides a host of services for the learner community. The National Digital Library of India (NDLI) was initiated in 2015 and launched on June 19, 2018. It is sponsored and mentored by Ministry of Education, Government of India, through its National Mission on Education through Information and Communication Technology (NMEICT). Filtered and federated searching is employed to facilitate focused searching so that learners can find the right resource with least effort and in minimum time. NDLI provides user group-specific services such as Examination Preparatory for School and College students and job aspirants.

Services for Researchers and general learners are also provided. NDLI is designed to hold content of any language and provides interface support for 10 most widely used Indian languages. It is built to provide support for all academic levels including researchers and life-long learners, all disciplines, all popular forms of access devices and differently-abled learners. It is designed to enable people to learn and prepare from best practices from all over the world and to facilitate

researchers to perform inter-linked exploration from multiple sources. It is developed, operated and maintained from Indian Institute of Technology Kharagpur.



Fig.1 Front page of the official website of NDLI

### Review of Literature

Bisma *et al.*, (2019) in the article “National Digital Library of India: An Overview” discussed the structure, sources and salient features of NDLI in brief. The study articulates the usefulness of NDLI in a nutshell.

Witten *et al.*, (2009) in the book “How to Build a Digital Library” discussed the steps included in the building procedure of a library and the fundamental idea of a digital library.

Ghosh, (2016) in the article “National Digital Library: A Platform For Paradigm Shift In Education And Research In India” states the structural details and data types of National Digital Library along with a brief discussion about the services it provided. The article makes awareness about using ICT tools for the advancement of digital library architecture and prototypes in India.

Rani & Aswath, (2020) in the article “Effectiveness of National Digital Library India (NDL) Portal in the field of Education and Research” discussed the portals and websites of NDL to analyse the resources submitted to the website and the problems faced while accessing it.

### Objectives of the Study

1. To study about the aims and objectives of National Digital Library of India creating an environment for digital library and its initiatives.
2. To study the activities and programmes offered by major service areas of NDLI.
3. To analyze the digital resources and their importance along with uses hosted by NDLI.

### Methodology

A thorough analysis of the NDL website was done to achieve the objectives mentioned above. Web content analysis of the NDL home page gives us a proper knowledge and insight to the website. Various article and books relevant to this study are taken under consideration and also for

literature review. The information was gathered from the ndl website up until January 24, 2024 and was examined using conventional percentages and displayed as tables and figures.

## **NDLI**

Choosing the National Digital Library of India (NDLI) can be advantageous for various reasons, depending on the context and the specific needs of users. Here are some potential reasons why one might choose the NDLI:

1. *Rich Content Repository*: The NDLI provides access to a vast and diverse collection of digital resources, including books, articles, theses, manuscripts, and multimedia content. This extensive repository can be valuable for researchers, students, and the general public.
2. *Open Access*: Many of the resources in the NDLI are available as open access, meaning users can freely access and use the content. This aligns with the principles of promoting knowledge sharing and accessibility.
3. *Curated and Quality Content*: The NDLI curates its content to ensure that it meets certain quality standards. This can be especially important for researchers and academics who rely on accurate and reliable information.
4. *Educational Support*: The NDLI aims to support educational institutions by providing a platform for teachers and students to access relevant learning materials. This can be particularly beneficial for remote learning and self-paced study.
5. *Multilingual Resources*: The NDLI offers content in multiple languages, making it inclusive and accessible to a broader audience. This is crucial for a country like India, which is linguistically diverse.
6. *Technological Infrastructure*: The NDLI leverages digital technology to ensure efficient access to information. The platform may offer advanced search capabilities, user-friendly interfaces, and features that enhance the overall user experience.
7. *Government Support*: The NDLI is an initiative of the Ministry of Education, Government of India. Government backing can signify a commitment to sustaining and improving the platform over time.
8. *Promotion of Digital Literacy*: The NDLI contributes to the promotion of digital literacy by providing an online platform for accessing educational resources. This aligns with the broader global trend of moving towards digital and online learning.
9. *Research Opportunities*: Researchers can benefit from the NDLI's extensive collection of academic and research materials, potentially saving time and resources compared to traditional methods of gathering information.

## **NDLI Content Analysis and Discussion**

In the official website, there are 4 types of e-resources can be found. Those are Test Preparation, Study at home, COVID-19 research repository and featured collections. The test preparation part covers study materials for CBSE examination, IIT-JEE, NEET, JAM, GATE, UGC NET and other competitive exams. After registering and log in user can search for materials as per their need that are available in the website.

The study at home part provides study materials like text book, self-assessment, lesson plan and extra-curricular as well as materials for competitive exams in a stream wise manner which is easily distinguishable as school, engineering, science, humanities, literature and law & management. The resources are displayed in subject wise manner for easy retrieval. Video lectures for learning are available to make the learning procedure more convenient and easy.

### **COVID-19 Research Repository**

The COVID-19 research repository provides access to large no of publications.

**Publications** - These are publications in high quality peer-reviewed journals/conferences collected from publishers' COVID pages and blogs, indexing pages with COVID, preprint archives, and open search of Web and other collections. Besides papers on biological, medical, and health aspects of COVID-19, papers on COVID-19 induced problems, challenges and opportunities in all facets of life (like Online Learning, Video Conferencing, etc.) are also included. Till now there are total 37,547 no of publications listed in the website. Moreover, blogs, indexed collections are also available. This part also provides data set from data repositories about COVID-19.

There is a document section containing COVID-19 information documents from various nationally and internationally credible organizations. These documents and videos have been collated from research perspective in COVID-19 and its induced effects. Hence, generic advisory, news etc. are not included. Moreover, a number of journal & conferences, Ideas and Funding, Challenges and start up in the field of COVID-19 are available.

**Featured Collection** - includes memorable events and displays their importance like person, sections are like birthdays of great people, person of the week, what special about the day, talk and webinars etc.

### **International Symposium (DLSDE)**

The National Digital Library of India (NDLI) is proud to announce its international symposium titled "Digital Libraries: Sustainable Development in Education". This symposium aims to bring together experts, educators, researchers, policymakers, and practitioners from around the world to discuss the role of digital libraries in promoting equitable and sustainable development in education. With this NDLI aims to contribute to the global dialogue on leveraging digital resources for achieving the United Nations Sustainable Development Goals (SDGs), particularly SDG 4 (Quality Education) (*Digital Libraries: Sustainable Development in Education (DLSDE)*, 2023).

### **NDLI Club**

National Digital Library of India Club (NDLI Club) is an enabler of career progression for students, job seekers, researchers and learners. NDLI Clubs are set up in institutes and nodal bodies, and these Clubs conduct events to facilitate students to develop knowledge, skill and traits beyond regular curriculum which are essential for their progression in respective professional domain. The events may be either physical or virtual. Virtual events are web-based and are conducted through the NDLI Club portal. The events are organized at respective institute level or city/district/state/regional level or all-India level. NDLI Club members can access a huge repository of free and open access learning resources, from anywhere and at any time, either through desktop PC or laptop or tablet or mobile, from National Digital Library of India (NDLI) (<https://www.ndl.gov.in> or <https://ndl.iitkgp.ac.in>). For creating club at institution, NDLI provides

a manual for registration and authority verification, after completing the procedure institution can participate as a club member in NDLI (*NDLI Club*, 2023).

### **Institutional Digital Repository (IDR)**

This voluntary collaboration between the Institutes and NDLI seeks to promote reading, research, and the spirit of enquiry among the students, academic teams, and management of the institutions, by making available metadata and in some cases full content of copyright free assets from these Institutes' repository for larger reach and dissemination.

For Institutes having challenges and limitations in IT resources, NDLI extends hosting and infrastructure support in form of providing dedicated hosting URL, repository application (D-Space) configuration support, and storage space. NDLI currently supports D-Space for hosting the IDR service (*NDLI: IDR Hosting Service*, 2023).

### **Disability Education & Engagement Portal for Access to Knowledge (DEEPAK)**

This Disability Knowledge Portal offers a special vertical for all information and resources regarding disabilities in India and across the world. This portal has information about blindness and low vision, deafness and hard of hearing and autism spectrum disorder only. This portal provides disability inclusion, and aware disable person about right of a disable person, Divyangjan. This portal help disabled people to find job vacancies as per their need (Fox, 2011).

### **CHAVI**

CHAVI - Comprehensive Archive of Imaging in Oncology is the first imaging bio bank dedicated to oncological imaging from India. Oncology is a discipline that is heavily dependant on imaging not only for diagnosis but also for therapy and post therapy follow up. Quantitative analysis of these images may provide additional insights about disease biology that may add to information available from clinical, pathological and -omics data. Image banks provide a way for researchers to get access to a large number of images which can be used for such analytical research.

CHAVI was initiated as a research partnership between two premiere research institutes in India - Tata Medical Center, Kolkata and the Indian Institute of Technology, Kharagpur. The project was developed as a part of the National Digital Library of India (FAIR sharing Team, 2023).

NDL promo videos in both Hindi and English language is available in the website, feedback log in makes the website more compatible. Moreover, the website can be translated into 11 different languages from India including Assamese.

### **Findings**

1. National Digital Library of India holds total 100,228,422no of resources.
2. The website provides searching and browsing facility as type, subject, source and learning resources.
3. The website has initiatives like IDR hosting, DEEPAK and CHAVI.
4. Bulk registration and NDLI Club registration are the methods to create an institutional registration and repository respectively.
5. The website is multilingual, so it reduces the language barrier.
6. NDLI offers study materials and video lectures for every stream and discipline from school level to higher education.
7. NDLI has a special data set and publication database along with research and scholarly content about COVID-19 collected from various sources.
8. NDLI plays a crucial role in the preservation of digital and digitized resources.

## Conclusion

From the above analysis we can conclude that NDLI is working as a virtual repository of India providing desirable resources. Remote access and availability is one of the most important aims of NDLI. NDLI's role in preserving digital and digitized resources underscores its significance in the educational landscape. The National Digital Library of India (NDLI) stands as a comprehensive and dynamic platform with a diverse range of educational resources catering to various needs. The four main categories of e-resources—Test Preparation, Study at home, COVID-19 Research Repository, and Featured Collections—reflect the platform's commitment to serving students, researchers, and the public at large. NDLI emerges as a multifaceted platform, aligning with educational goals, research endeavors, and the broader societal context, making a substantial contribution to the dissemination and preservation of knowledge in diverse fields.

## References

- [1] Bisma, B., Nahida, N., & Loan, F. A. (2019). *National Digital Library of India: An Overview* [Journal article (Unpaginated)]. *Library Philosophy and Practice*; University of Nebraska - Lincoln. <http://eprints.rclis.org/44928/>.
- [2] *Digital Libraries: Sustainable Development in Education (DLSDE)*. (2023). Retrieved January 25, 2024, from <http://iconf.ndl.gov.in/>.
- [3] FAIR sharing Team. (2023). *FAIR sharing record for: CHAVI - Comprehensive Archive of Imaging in Oncology* [dataset]. FAIR sharing. <https://doi.org/10.25504/FAIRSHARING.AE3851>.
- [4] Fox, S. (2011, January 21). Americans living with disability and their technology profile. *Pew Research Center: Internet, Science & Tech*. <https://www.pewresearch.org/internet/2011/01/21/americans-living-with-disability-and-their-technology-profile/>.
- [5] Ghosh, M. (2016). National Digital Library: A Platform For Paradigm Shift In Education And Research In India (ISSN-0036-8156). *Science and Culture*, 82, 1–11.
- [6] *National Digital Library of India*. (2023). Retrieved January 25, 2024, from <https://ndl.iitkgp.ac.in/>.
- [7] *NDLI Club*. (2023). Retrieved January 24, 2024, from <https://club.ndl.iitkgp.ac.in/club-home>.
- [8] *NDLI: IDR Hosting Service*. (2023). Retrieved January 25, 2024, from <https://ndl.iitkgp.ac.in/idr>.
- [9] Rani, N. R. S., & Aswath, L. (2020). Effectiveness of National Digital Library India (NDL) Portal in the field of Education and Research. *Journal of Indian Library Association*, 55(3), Article 3.
- [10] Witten, I. H., Bainbridge, D., & Nichols, D. M. (2009). *How to Build a Digital Library*. Morgan Kaufmann.

# Utilization of Electronic Databases by Users of Doon University

Shrikrishan<sup>1</sup> and Dr. Dhiraj Sharma<sup>2</sup>

<sup>1</sup>Research Scholar, <sup>2</sup>Assistant Professor

<sup>1&2</sup>Department of Library and Information Science, Mangalayatan University, Aligarh, India  
E-mail: 20211296\_shrikrishna@managalayatan.edu.in, dhiraj.sharma9586@managalayatan.edu.in

## Abstract

*This article's goal is to examine the effects and utilization of electronic databases at the Doon University library because a substantial amount of money is spent on their expansion, management, and subscription. Finding out who uses electronic databases, how satisfied they are with their use, what problems they have, and whether they need help or guidance using them is the main objective. 250 registered users were randomly selected to fill out a questionnaire in order to collect data for research. Doon University students' completed surveys totaling 143 were received back. Finally, the investigator selected for the analysis, 137 valid questionnaires were employed, utilizing statistical methodologies. The study shows that users heavily utilized resources from databases like JSTOR, Science Direct, IEEE, EBSCO, Taylor and Francis, and others. A huge majority of users got training and individual tutoring in accessing databases at Doon University central library. In order to boost the usage of the databases at the Central library, the study emphasizes the importance of user education programs and information literacy initiatives.*

**Keywords:** Electronic Resources, Electronic Databases, Users, Utilization, Library, Doon University.

## Introduction

Libraries nowadays house more than only print materials like books, periodicals, and journals. Currently, libraries are using less traditional printed materials and more technologically driven services and electronic resources (Nnadozie and Nwosu, 2016; Okazie, 2016). While using electronic resources makes it easier to access a vast array of Library materials, there is still value in using printed resources (Okazie, 2016). Changes in the ICT sector are responsible for the transition in library resource content from printed to online information resources (Israel and Edesire, 2016). Additionally, they enable users to access electronic knowledge sources, as e-learning is revolutionizing education and bringing a new dimension to learning (Bajpai *et al.*, 2016). Additionally, the technological revolution has made it unnecessary for libraries to be physically located in order to provide knowledge to their patrons. The main explanation is that ICT is significantly reducing geographic barriers globally (Prakash, 2017). Libraries have also banded together to collaborate in order to make resource sharing easier.

Furthermore, utilizing technology in libraries is now a must rather than a choice in the information era (Dar *et al.*, 2017). Libraries are gradually introducing resource sharing to reduce costs and meet customer requests (Prakash, 2017). This establishes a direct line of communication between libraries and information services that will influence the way that knowledge is found and disseminated in the digital era (Atram, 2017). Libraries now offer significantly better services because of the advances in information technology brought about by their use.

## Electronic Database

A large, regularly updated collection of digital information about a particular subject or field, consisting of records in a standard format that are organized for simple and quick search and retrieval (bibliographic records, abstracts, full-text articles, directory entries, photos, statistics, etc.). Once the content has been converted to machine-readable form (BIOSIS), it is created by the



database producer (Thomson Reuters) and published in print form (Biological Abstracts). It is then leased to one or more database vendors who use proprietary search software to provide electronic access to the data.

An electronic database that is updated and/or expanded often to offer up-to-date information, incorporate recently published sources, and covers a limited number of topics instead of a broad one, usually for a small audience. Most journal databases are updated often as new issues are published and indexed. Full-text reference materials, periodicals indexes, abstracting services, and catalogs that are leased annually under license agreements with access limited to registered borrowers and library staff make up the majority of databases used in libraries (ODLIS).

These days, electronic databases exist in a plethora of formats, such as image databases, statistical databases, and many more. Due to their increased correctness and accessibility from any location, these databases are becoming more and more important over time. When doing R&D jobs, these computerized databases are quite helpful and save a lot of time.

### **Literature Review**

Electronic resources, which are enabled by computers, network connectivity, electricity, and other supporting components—but primarily by people—make digitalized knowledge accessible. It can be found in many different formats, such as text, music, video, graphics, tables, and still photos. Electronic resources are information sources that can be accessed electronically via the Internet or other digital media. Information resources that are accessible online, via CDROM, as e-books or journals, in online databases, or via other computer-based electronic networks are referred to as electronic resources by Bankole, Ajiboye, and Otunla (2015).

Yakubu and Olatoye (2015) describe electronic resources as information kept on devices such as CD ROMs, hard drives, flash drives, and the internet. It could take the form of a database programme created especially for a certain organization that stores data and makes it easy to access, store, and retrieve. However, employing these internet tools has had variable degrees of beneficial and bad impacts. Some recent research, including those by Verma and Lalflanmawii (2016), Mollel (2016), and Alphonc (2015), show that the subscription resources are used insignificantly, while others, like those by Kumar (2016), Mammo and Ngulube (2015), and Singh (2013), revealed that the subscribed resources are used significantly by user communities.

At the University of Jamia Millia Islamia, all users had access to electronic resources, according to Singh (2013). Similarly, Nijalingappa Medical College students were in favor of using electronic resources for teaching, learning, and research, according to Uplaonkar and Keshva (2013). They specifically point out that online databases such as Emerald, EBSCO, and PROQUEST are often utilized by researchers and students in general. Furthermore, even in rural areas, e-resources are easy to access (Khan, 2016). Kumar (2016) claims that using e-resources enhances research, teaching, career development, communication, and subject-specific and current knowledge.

### **Objectives, Scope and Limitation**

In academic libraries, e-databases are becoming a much larger component of the collection. The libraries receive substantial funding for the development of e-databases. The purpose of the study is to ascertain whether electronic databases are used in the library that is the subject of the investigation, as well as the advantages, efficacy, and difficulties that users have when utilizing them. The purpose of this study was to get user input regarding the influence of e-databases on the Doon University library and how they are used. The study's objectives were to:

1. To identify the frequently used e-databases by users.
2. To determine the purpose for which users use e-databases.
3. To determine the awareness and use of available e-databases.
4. To determine the problems faced and the types of instruction/help received by the users.

The scope and limitation of the study is confined to the users (postgraduate students and research Scholars) of Doon University Central library regarding the effective use of e-databases.

### Research Methodology

Doon University was selected to conduct a thorough examination because India is home to numerous intellectual universities. A questionnaire survey was the research technique used to collect the data for the study. A validated questionnaire was randomly sent to 250 (10.23%) registered postgraduate students and research scholars at Doon University, and 143 (57.2%) of those students returned the completed questionnaires. In order to obtain the qualitative and quantitative data, the researcher also selected 137 (54.8%) legitimate surveys for statistical analysis and interpretation.

### Data Analysis and Interpretation

#### 1. Frequency to Visit the Library

The impact and utilization of electronic databases at Central Library were assessed with the aid of the analysis and description of the study, which showed that 90 (60%) of the useable questionnaires came from postgraduate students and 47 (47%) from research researchers. Based on the data collected, it was found that postgraduate students accounted for the majority of respondents, receiving 90(or 60%) of the questionnaires.

TABLE I FREQUENCY TO VISIT THE LIBRARY

Frequency	Respondents	
	P. G. Students N=90	Research Scholars N=47
Daily	16 (17.78%)	20 (42.55%)
2-3 Times in a Week	46 (51.11%)	22 (36.81%)
Once in a Month	21 (23.33%)	3 (6.38%)
Occasionally	1 (1.11%)	1 (2.13%)
Never	6 (6.67%)	1 (2.13%)

For the simplicity of the study, the frequency of visits for accessing e-databases has been split into five groups, as table I shows. While 46.81% of research scholars and 42.55% of postgraduate students visited the library every day, respectively, the majority of postgraduate students (51.11%) visited the library two to three times each week.

#### 2. Purpose of Usage of Electronic Databases

Knowing the goal is essential to using e-databases. Table II shows that 48.93% and 29.79% of research scholars and 50% and 25.56% of postgraduate students, respectively, used the accessible e-databases for their study and to download publications and refresh their knowledge.

TABLE II PURPOSE OF USAGE OF ELECTRONIC DATABASES

Purpose	Respondents	
	P. G. Students N=90	Research Scholars N=47
To Update Knowledge	23 (25.56%)	14 (29.79%)
To Consult Databases for Research	18 (20%)	23 (48.93%)
To Download Articles	45 (50%)	6 (12.77%)
All the Purpose	4 (4.44%)	4 (8.51%)

3. Awareness and Utilization of Electronic Databases

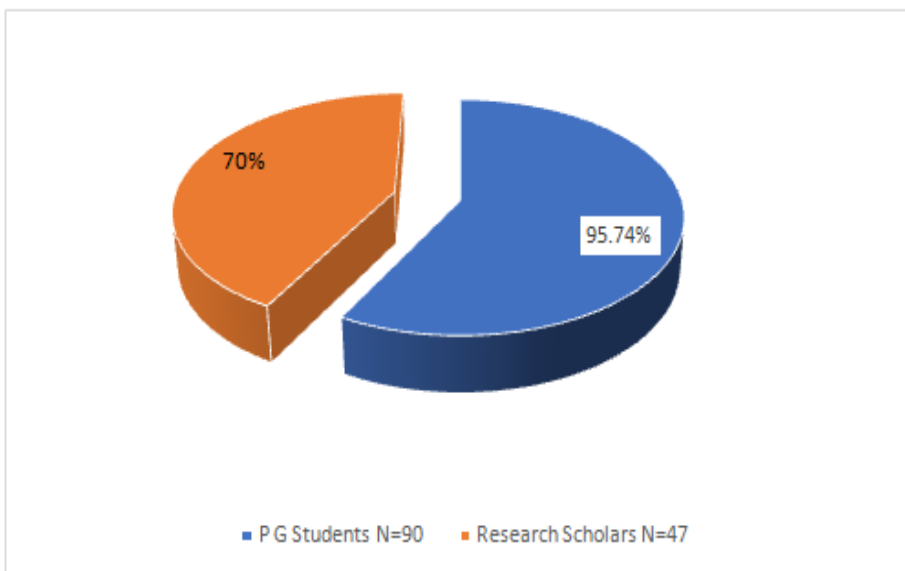

Fig. 1 Awareness and Usage of Electronic Databases

As illustrated in fig. 1. Central library is currently home to a large number of e-databases. The majority of postgraduate students (70%) and research researchers (95.74%) were well-aware of the databases that were available and utilized them for a range of purposes.

The library has subscriptions to several internationally known e-databases, which are currently indispensable tools for law libraries, for searching the most recent law study material. Based on the information shown in Table III, which deals with e-database usage, the majority of postgraduate students (42.86%) used Hein Online, with Westlaw India (33.33%), SCC Online (30.16%), and JSTOR (23.81%) following in that order.

Although the percentage of postgraduate students who frequently used Lexis Advances, Taylor and Francis, and EBSCOHOST e-databases was 41.27%, 26.98%, 25.40%, and 22.22%, respectively.

Similarly, Hein Online was used by 62.22% of research academics the most, followed by JSTOR (57.78%), SCC Online (35.56%), and Westlaw India (32%). The table also made it evident which e-databases are more frequently used by researchers.

## 4. Frequency of Utilization of Electronic Databases

TABLE III FREQUENCY OF USING E-DATABASES

Database	Respondents											
	P. G. Students						Research Scholars					
	MF	F	S F	R	N	M (R)	M F	F	SF	R	N	M (R)
Hein online	27 (42.86)	16 (25.40)	8 (12.70)	3 (4.76)	9 (14.28)	2.78 (12)	8 (62.22)	10 (22.22)	3 (6.67)	3 (6.67)	1 (2.22)	3.36 (2)
JSTOR	15 (23.81)	26 (41.27)	8 (12.70)	4 (6.35)	10 (15.87)	2.51 (22)	3 (51.11)	13 (28.89)	1 (2.22)	4 (8.89)	4 (8.89)	3.04 (3)
SCC Online	19 (30.16)	14 (22.22)	13 (20.63)	4 (6.35)	13 (20.63)	2.35 (41)	6 (35.56)	9 (20)	2 (4.44)	7 (15.56)	11 (24.44)	2.27 (4)
EBSCOHOST	9 (14.28)	12 (19.05)	6 (9.52)	8 (12.70)	28 (44.44)	1.46 (5)	9(20)	15 (33.33)	2 (4.44)	1 (2.22)	18 (40)	1.91 (6)
Westlaw India	21 (33.33)	15 (7.94)	7 (26.98)	5 (7.94)	5 (7.94)	15 (23.81)	38 (32)	6 (57.78)	17 (37.78)	1 (2.22)	1 (2.22)	3.49 (1)
Lexis Advance	5 (7.94)	10 (15.87)	7 (11.11)	8 (12.70)	33 (52.38)	1.4(14.7)	8(17.78)	5 (11.11)	7 (15.56)	2 (4.44)	23 (51.11)	1.40 (8)
Taylor & Francis	6 (9.52)	8 (12.70)	10 (15.87)	6 (9.52)	33 (52.38)	1.17 (61)	3 (28.89)	7 (15.56)	7 (15.56)	1 (2.22)	17 (37.78)	1.96 (5)

(MF=Most Frequently, F= Frequently, SF=Somewhat Frequently, R= Rarely, N=Never, M=Mean &R=Rank)  
(Figures in parentheses are percentage)

## 5. Reason for Unawareness about Electronic Databases

Table IV attempts to explain why 51.85% and 33.33% of postgraduate students, respectively, were not using e-databases because of a lack of skills and time, while 50.0% and 50.0% of research scholars were not using e-databases because of poor facilities and lack of time.

TABLE IV REASON FOR UNAWARENESS

Reason	Respondents	
	P. G. Students N=27	Research Scholars N=2
Lack of Skills	14 (51.85%)	-
Costly	-	-
Lack of time	9 (33.33%)	1 (50%)
Poor Facility	4 (14.81%)	1 (50%)

### 6. Hindrance in Utilization of Electronic Database

TABLE V PROBLEMS IN USING ELECTRONIC DATABASE

Problems	Respondents			
	P. G. Students N=63		Research Scholars N=45	
	YES	NO	YES	NO
Technical	7 (11.11%)	56 (88.89%)	3 (6.67%)	42 (93.33)
Connectivity	15 (23.81%)	48 (76.19%)	14 (31.11%)	31 (68.89%)
Downloading	16 (25.40%)	47 (74.60%)	11 (24.44%)	34 (75.56%)
Interrupted Power Supply	5 (7.94%)	58 (92.06%)	1 (2.22%)	44 (97.78%)
Lack of guidance	34 (53.97%)	29 (46.03%)	11 (24.44%)	34 (75.56%)

It is imperative to comprehend the difficulties that research scientists and graduate students have when utilizing electronic databases, as illustrated in Table V. A review of the tabulated data reveals that delayed downloading was the main cause of problems for postgraduate students (53.97%), followed by a lack of instruction (25.40%), and connectivity problems affected 31.11% of research scholars.

### 7. Types of Instruction/Help in Using Electronic Databases

TABLE VI TYPES OF INSTRUCTION/HELP IN USING ELECTRONIC DATABASES

Instruction	Respondents	
	P. G. Students N=31	Research Scholars N=25
Training given by the library	17 (54.84%)	12 (48%)
Online Instruction/guidance	10 (32.26%)	8 (32%)
Individual Instruction	15 (48.89%)	12 (48%)
Help by Your Library Colleagues	6 (19.35%)	8 (32%)

Many guides on utilizing e-databases at the library are part of the user education program. Table VI shows that 54.84% of postgraduate students received teaching from the library on how to use electronic databases, with individual library staff instruction coming in second place with 48.89% of the students.

Although 48% of the research scholars received one-on-one instruction from library staff after attending group instruction on e-database usage (48%).

### 8. Satisfaction with Electronic Database

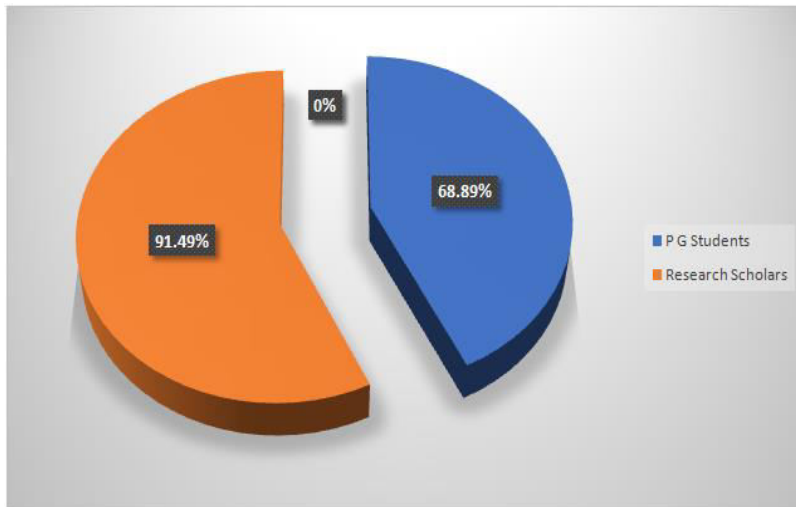

Fig.2 Satisfaction with Electronic Database

Fig. 2 shows that most research researchers (91.49%) and postgraduate students (68.89%) were happy with e-databases. This demonstrates unequivocally that university research experts preferred the format of electronic databases.

#### Summary of Findings

The following succinctly describes the findings of the study conducted at Doon University Central Library on the use of electronic databases by research scientists and postgraduate students:

1. Most postgraduate students and research scholars used the library twice a week or everyday to access the numerous e-databases.
2. Postgraduate students and research professors use e-databases extensively for downloading articles and doing research, respectively.
3. The majority of research scholars and postgraduate students were aware of the available e-databases and used them to achieve their goals.
4. The databases that postgraduate students and research researchers used the most frequently were Hein Online, JSTOR, and SCC Online, based on their average usage frequency score and rankings of e-databases.
5. Postgraduate students did not use e-databases because they lacked the essential skills, whereas research professors did not use them due to a lack of time and resources.
6. The majority of postgraduate students experienced poor download speeds and a lack of support, while research researchers who used e-databases also experienced connectivity problems.
7. The majority of graduate students and research scientists had help or instruction in using e-databases.
8. Most postgraduate students and research scholars got individualized training and teaching on how to use e-databases.
9. The university's research researchers selected these resources because they were satisfied with the e-databases that were available to them.

## Conclusion

Technology breakthroughs caused academic university libraries to transition from a traditional to a digital setting. A great number of e-databases are now being subscribed to by law libraries in order to meet the constantly growing demands of users. The ability to use the existing databases effectively requires a sufficient level of computer literacy. The study provides guidance on the efficient use of modern electronic databases, but with some restrictions.

Thus, this research proposes the following:

1. Because services are being given globally, the university library should have more databases of electronic materials subscribed to. University libraries should also purchase and install more networked computers with the appropriate software to allow patrons to search and browse for the necessary information. Lastly, they should make a greater effort to notify people about the availability of electronic resource databases.
2. Services that were once user-centered are now library-centered. The university library may consider using text messaging, email alert systems, and awards for frequent users of electronic resource databases as promotional techniques. Librarians and other library staff members should continue to hone their skills by attending additional training sessions on searching and retrieving from electronic databases in order to better advise users.

## References

- [1] Al – Suqri, Lillard & Al – Saleem (2014). Information Access and Library Users Needs in Developing Countries. Premier reference source 116, 125.
- [2] Prakash, I. N., (2017). Resource Sharing: A Library Perceptive. International Journal of Library & Information Science (IJLIS). Vol. 6(1), pp. 19–22, Article ID: IJLIS\_06\_01\_002 Available online at <http://www.iaeme.com/IJLIS/issues.asp>.
- [3] Saikia, M. and Gohain, A. (2013). "Use and User's Satisfaction on Library Resources and Services in Tezpur University (India): a study" Library Philosophy and Practice (ejournal). Paper 972. <http://digitalcommons.unl.edu/libphilprac/972>.
- [4] Swain, Dillip K. (2010), "Students' keenness on use of e-resources", *The Electronic Library*, Vol. 28 No. 4, pp. 580-91.
- [5] Toner, L. (2008), "Non-use of Library Services by Students in a UK Academic Library," *Evidence Based Library and Information Practice*, Vol. 3 No. 3, available at: <http://ejournals.library.ualberta.ca/index.php/EBLIP/article/view/1330/1241>.
- [6] Uplaonkar, Shilpa and Keshva (2013). Use of electronic information resources and services in S. Nijalingappa medical College: A study. *Library Progress (International)*, 33(1), 1-11.
- [7] Verma, M.K., & Laltnanmawii, R. (2016). Use of library collections and services by faculties and research scholars of school of physical sciences, Assam University, Silchar: a study.
- [8] Yakubu, H. & Olatoye, O. O. (2015). Use of Electronic Resources in Teaching and Learning at Federal University Dutsinma, Nigeria. *Mediterranean Journal of Social Science*, 6(1), 584-592.

# Hyflex Libraries: Bridging the Gap Between On-Campus and Online Resources

Dr. Sudhi S. Vijayan<sup>1</sup>, Dr. V. R. Arunkumar<sup>2</sup> and Dr. V. R. Renjith<sup>3</sup>

<sup>1</sup>Assistant Professor & Head, Department of Library and Information Science

<sup>2</sup>Assistant Librarian Gr. II, Kerala University Library

<sup>3</sup>Librarian, Department of History,

<sup>1,2&3</sup>University of Kerala, Karyavattom Campus, Thiruvananthapuram, Kerala, India

E-mail: sudhivijayan@keralauniversity.ac.in, arunkumarvr@keralauniversity.ac.in,

renjithlib@keralauniversity.ac.in

## Abstract

*This study explores the novel idea of hyflex libraries, which are inclusive and flexible learning environments created by fusing technology and conventional classroom settings. Like other hybrid learning programs, Hyflex libraries offer students equal access to information, flexible learning modalities, and possibilities for collaboration by seamlessly integrating online and on-campus resources. In examining the importance of bridging the gap between in-person and online learning, the essay emphasizes how transformative it can be for both teachers and students. The technological tools used in hyflex libraries, access platforms, implementation issues, collaboration techniques, and future trends are all covered in detail. The effects of technological developments are also examined, including improved integration of virtual and augmented reality, artificial intelligence for tailored education, and 5G technology for uninterrupted communication. The essay emphasizes the continued dedication to meeting a range of needs in the always changing field of education.*

**Keywords:** Hyflex Libraries, On-Campus, Online Resources, Technological tools.

## Introduction

The convergence of technology and conventional learning settings has led to creative ways that meet today's students' diversified demands. These revolutionary tactics include "hyflex libraries" as a beacon of adaptation and inclusion. COVID-19 has had a global impact and forcing the hand of education institutions to implement more creative ways to teach while maintaining high quality learning interaction (Sanchez-Pizani, 2022). Imagine a venue where on-campus and online materials blend, giving students a seamless experience across locations. This article embarks on a journey to explore the dynamic world of hyflex libraries, dissecting their significance in the educational realm and delving into how they effectively bridge the gap between physical and virtual learning resources. Hyflex libraries are a pioneering reaction to educational innovation in academia, where flexibility and accessibility are in great demand—the layers of this concept reveal its transformational potential for students and educators. HyFlex allows students to avoid expensive commutes and scheduling difficulties by providing a good balance between work, family, and other obligations (Eshet *et al.*, 2023).

## Hyflex Libraries

Hyflex libraries provide educational flexibility and adaptation by combining on-campus and online resources. Hyflex libraries combine flexibility and technology to create dynamic information centres. The word "hyflex" combines "hybrid" and "flexible," describing a learning environment that smoothly integrates physical and virtual resources. Hyflex libraries combine on-campus and online resources to meet the demands of contemporary students. It challenges the traditional library concept by transcending physical space and enabling information access without time or geographical limits.



### **Significance of Bridging the Gap**

The evolving landscape of education has witnessed a paradigm shift in how students engage with learning resources. Hyflex libraries improve education by connecting on-campus and online resources. This strategic integration covers the diverse demands of modern learners and supports the following:

- a) *Flexibility in Learning Modalities*: Hyflex libraries allow students to choose their favourite method of instruction, whether in-person or online. This flexibility fits a variety of interests and learning styles.
- b) *Adjust to Changing Conditions*: Seamless transfers between on-campus and online resources strengthen educational infrastructure in the face of unpredictable events and changes in global dynamics. Hyflex libraries provide learning and situational adaptation.
- c) *Equitable Access to Information*: Hyflex libraries close the gap, eradicating socioeconomic and geographic disparities. Every student has access to information, democratizing education and encouraging inclusivity.
- d) *Collaborative Learning*: Integrating online and on-campus resources improves learning collaboration and interaction. Research, group projects, and discussions may establish a global learning community even when participants are not physically present.
- e) *Availability*: Hyflex libraries are available around the clock, diverting from regular hours of operation. Students may access the material anytime using the online component, which accommodates various schedules and time zones.
- f) *Customized Learning Paths*: Students may customize their education by integrating online and on-campus resources. Learners may customize their educational experiences at a library or online.
- g) *Technological Empowerment*: Hyflex libraries use technology to enhance learning. Multimedia resources, virtual technology, and interactive platforms enable education to achieve 21st-century digital fluency criteria.
- h) *Effortless Transition between Environments*: Students moving between real and virtual learning environments experience less emotional conflict when integrating on-campus and online materials seamlessly. This smoothness improves learning.

### **Technological Tools in Hyflex Libraries**

Hyflex libraries' popularity depends on easily integrating several technologies and platforms. These technologies make remote and on-campus studying easier and boost resource accessibility.

- a) *Learning Management Systems (LMS)*: Several Hyflex libraries employ LMS to centralize resource access. These systems provide a standardized virtual classroom for course materials, e-books, and conversations.
- b) *Virtual Collaboration Tools*: Google Meet, Microsoft Teams, Zoom, and others enable collaboration. These approaches enable real-time faculty-student involvement, virtual study groups, and live streaming of on-campus lectures, creating an inclusive learning environment.
- c) *Digital Repositories and Databases*: Hyflex libraries typically use databases and digital repositories. Institutions invest in ProQuest, JSTOR, and others so students may access multimedia, e-books, and academic papers anywhere.
- d) *E-Books and Journals Platforms*: Hyflex libraries provide EBSCO host, Kindle, and Over Drive e-books and periodicals. These systems let student's access course materials and other resources remotely.
- e) *Library Management Systems*: The Library Management system includes cataloguing, organizing, and managing digital and physical materials in Hyflex libraries. These

technologies simplify inventory management and help students find material online and in person.

- f) *Mobile Apps*: Hyflex libraries provide mobile apps for students to use on the go. These applications usually provide push alerts for library changes, e-book borrowing, and resource searches.
- g) *Augmented Reality (AR) and Virtual Reality (VR)*: Modern hyflex libraries use VR and AR to improve learning. These technologies may provide immersive learning, interactive library tours, or complicated subject visualizations.
- h) *Cloud-Based Services*: Google Drive, Dropbox, and institutional cloud storage enable students to save, distribute, and cooperate on academic papers and projects, facilitating their ability to retrieve material from any device for both remote and on-campus learning.
- i) *Integrated Library Systems (ILS)*: Integrated Library Systems (ILS) automates acquisitions, circulation, and cataloguing. These solutions help Hyflex libraries manage digital and physical resources.

### Accessing Platforms

There are different platforms that play a significant role in enabling smooth access to various services, information, or technologies. Some of them are

- a) *Remote Access*: Students may access e-books, journals, and databases anywhere with an internet connection. Students can engage with course materials at their convenience.
- b) *Real-Time Collaboration*: Virtual technologies enable real-time collaboration between students, scholars, and libraries. Synchronous conversations and group projects help allow students to participate remotely.
- c) *Mobile-Friendly Interfaces*: Students may use smartphones and tablets to access library items via mobile apps and flexible interfaces. Mobility and many learning techniques are made possible by this accessibility.
- d) *Integrated Learning Environments*: Integrating LMS and hyflex libraries produces unified learning environments. A single digital platform lets students switch between course materials, library resources, and collaboration tools.
- e) *Personalized Learning Paths*: Technology allows personalized learning paths. Personalizing learning materials to students' interests and learning styles boost autonomy and engagement.
- f) *User-Friendly Interfaces*: User-friendly interfaces and design may enhance user experience. Students use physical and digital interfaces to find and use resources.
- g) *Analytical Insights*: Technology allows hyflex libraries to gather analytics and user feedback. This data-driven approach helps schools assess, develop, and meet student needs.

### Challenges in Implementing Hyflex Library Services

Hyflex libraries need good technology to succeed. Institutions may need help providing dependable internet connection, updating gear and software, and assisting students and staff with digital tools.

- a) *Technological Infrastructure*: Hyflex libraries need solid technology. Establishments often struggle to maintain equipment and software, provide workers and students with a stable internet connection, and help them use digital tools.
- b) *Staff Training and Development*: Hyflex library services need staff to adopt new technology and adapt to changing teaching techniques. Library staff must be trained to assist remote and on-campus students.

- c) *Equitable Access to Technology*: Providing equitable technological access to students is challenging. Some students may have device or internet access issues. Institutions must address these gaps to sustain hyflex inclusiveness.
- d) *Data Security and Privacy Concerns*: Companies must prioritize data security and privacy as digital platforms grow. Protecting sensitive data and following data protection laws is essential.
- e) *Balancing Physical and Virtual Resources*: Balancing physical and virtual resources is difficult. Collections must be carefully chosen to accommodate students' different requirements and acknowledge the hyflex learning style.
- f) *Faculty and Student Engagement*: Intentionality is required to involve teachers and students in the hyflex. Faculty may need assistance developing an engaging online curriculum, while students may need guidance in navigating hybrid learning.
- g) *Evaluation & Assessment Methods*: Developing fair and appropriate evaluation systems for in-person and online learners is challenging. Institutions must include several learning contexts in their assessment programmes to properly evaluate student achievement.
- h) *Cost Considerations*: Technology, staff training, and maintenance may be needed to implement and maintain hyflex library services. Institutions must consider financial consequences before distributing resources.

### **Fostering Collaboration in Hyflex Libraries**

Hyflex libraries need adaptable venues for in-person and remote participation. This method, commonly used in educational settings, allows individuals to choose between attending a physical location and participating remotely.

- a) *Virtual Collaboration Tools*: Video conferencing, internet forums, and collaborative document editing are used in Hyflex libraries. These technologies enable real-time student, teacher, and library contact, creating community and shared learning.
- b) *Group Projects and Study Spaces*: Hyflex libraries are intended for group work and learning. Flexible furniture, collaboration spaces, and integrated digital hubs allow students to communicate both on campus and remotely.
- c) *Online Discussion Platforms*: Dedicated online discussion platforms provide a space for students and teachers on course material, research, and academic interests. These platforms encourage collaboration by removing physical obstacles.
- d) *Virtual Study Groups*: Hyflex libraries provide online study groups where students may work together on assignments, exchange materials, and have class discussions. Beyond physical closeness, a collaborative learning atmosphere is promoted.
- e) *Faculty-Student Interaction*: Collaborations allow Library staff to learn research skills, resource navigation, and information literacy. Collaboration between learners and teachers is encouraged via seminars, webinars, and one-on-one consultations.
- f) *Library Staff Participation*: Library staff provides information literacy, research, and resource navigation skills to projects. Through seminars, webinars, and individual consultations, they foster student-teacher collaboration.
- g) *Integrated Learning Management Systems (LMS)*: Hyflex libraries in the Learning Management System (LMS) allow teachers to share course materials, students to collaborate on assignments, and library staff to give resources and help. Integration improves communication and teamwork.

### **Future Trends in Hyflex Libraries**

Rapid technological breakthroughs are shaping the future of Hyflex libraries, focusing on immersive, personalized, and safe learning environments. These developments demonstrate the

continued commitment to supporting students and faculty's diversified demands in a changing educational context.

- a) *Enhanced Virtual Reality (VR) and Augmented Reality (AR)*: Integration Future hyflex libraries may investigate new technologies for immersive learning experiences. This might include virtual library tours, interactive 3D resource models, and augmented reality in libraries.
- b) *Artificial Intelligence (AI) for Personalized Learning*: AI algorithms can analyze user preferences, learning styles, and behaviour. This data might be utilized to customize resource suggestions, learning routes, and assistance, making learning more personalized.
- c) *Enhanced Security and Resource Tracking with Block chain*: Block chain technology may improve digital resource security and offer a verified record of use. Tracking digital asset provenance and academic work integrity may benefit from this.
- d) *Advanced Analytics for Continuous Improvement*: Institutions may examine user behaviour, resource utilization, and library service effectiveness using advanced analytics. Data-driven strategies may improve user experience, strategic decisions, and resource and support delivery.
- e) *Integration of Extended Reality (XR) Technologies*: Beyond VR and AR, XR integration may expand. This might improve education with unique learning environments that seamlessly blend physical and digital elements.
- f) *Expanded Collaboration with External Partners*: Hyflex libraries may work with other libraries, publishers, and technology providers. Shared resources, greater digital collections, and collaboration may enhance user services.
- g) *Greater Emphasis on Open Educational Resources (OER)*: Hyflex libraries may prioritize curating and marketing OER as demand for free educational materials rises. This movement promotes education's affordability, accessibility, and inclusiveness.
- h) *Gamification Elements for Engagement*: Future hyflex libraries may integrate gamification to boost user engagement. Learning with interactive quizzes, assignment badges, and other game-like aspects may be more entertaining.

### **Impact of Advancements in Technology**

- a) *5G Technology for Seamless Connectivity*: Hyflex libraries may benefit from the broad deployment of 5G technology, which offers quicker and more dependable connections. Real-time cooperation, high-quality video streaming, and online service responsiveness may improve.
- b) *Edge Computing for Reduced Latency*: Advanced edge computing may minimize latency in accessing digital resources, providing a smoother experience for consumers using on-campus and online services. This benefits resource-intensive applications like virtual simulations and augmented reality..
- c) *Voice-Activated Interfaces and AI Assistants*: The integration of voice-activated interfaces and AI assistants could simplify user interactions with hyflex library systems. Users might use voice commands to search for resources, receive recommendations, or interact with virtual assistants to get information and support.
- d) *Biometric Authentication for Enhanced Security*: The adoption of biometric identification technologies like fingerprint or face recognition may improve the security of user accounts and access to digital resources. This may improve on-campus and distant authentication security and usability.
- e) *Block chain for Credentialing and Digital Libraries*: Block chain technology may be used for secure credentialing and decentralized digital libraries. Users might safely access their academic credentials and help build decentralized, trustworthy scholarly resources..

- f) *Advancements in Wearable Technology*: The use of wearable technology, such as augmented reality glasses or smart watches, may expand access to library materials and services. These gadgets may provide seamless information access and notification, improving user experience.
- g) *Adaptive Learning Platforms*: Technological developments may lead to more advanced adaptive learning systems in hyflex libraries. These systems might adapt content and resources to learner progress, preferences, and performance.
- h) *Enhanced Cyber security Measures*: Hyflex libraries may invest in sophisticated cyber security measures to safeguard sensitive user data, digital collections, and library systems as technology advances. This involves using modern encryption, intrusion detection, and proactive security.

## Conclusion

Hyflex libraries revolutionize education by combining online and on-campus resources to meet the evolving demands of teachers and students. The pandemic led to a rise in online learning in higher education. HyFlex was explored by students looking for new educational possibilities and by institutions with limited funding (Howell, 2022). The adaptability, accessibility, and collaborative features of Hyflex libraries highlight the need to link physical and virtual learning. Learning management systems and augmented reality enhance creative learning environments. Hyflex libraries may provide inclusive learning environments despite equal access and technology infrastructure issues. As technology develops, immersive learning, customized experiences, and improved security are anticipated. In addition to wearable technology, edge computing, 5G, voice-activated interfaces, and seamless learning environments, Hyflex libraries may also be helpful. Hyflex libraries are effective change agents because of their dedication to collaboration and flexibility in response to the ever-evolving educational landscape.

## References

- [1] Eshet, Yovav, Nomy Dickman, & Yossi Ben Zion (2023). Academic integrity in the HyFlex learning environment. *Heliyon*, 9(2), <https://doi.org/10.1016/j.heliyon.2023.e13301>.
- [2] Howell, E. (2022), "HyFlex model of higher education: understanding the promise of flexibility", *On the Horizon*, 30(4), 173-181. <https://doi.org/10.1108/OTH-04-2022-0019>
- [3] Sanchez-Pizani, R., Detyna, M., Dance, S. & Gomez-Agustina, L. (2022). Hybrid flexible (HyFlex) seminar delivery – A technical overview of the implementation. *Building and Environment*. 216, 109001. <https://doi.org/10.1016/j.buildenv.2022.109001>.

# Digital/Virtual Libraries in Academic Institutions (DL): Smart Libraries

M. C. Yeswanth<sup>1</sup> and Dr. K. Vijaykumar<sup>2</sup>

<sup>1</sup>Research Scholar (External), <sup>2</sup>Associate Professor

<sup>1&2</sup>Dept.of Library & Information Science, Annamalai University, Tamil Nadu, India

E-mail: eswanth74@gmail.com, aulisvijayakumar@gmail.com

## Abstract

*Libraries are becoming smart spaces that leverage cutting-edge technologies to give patrons better services and experiences in the ever-evolving information and technology ecosystem. In order to enhance library operations and engage users in new ways, this study investigates the idea of smart libraries with a particular focus on the integration of digital technology, automation, and data analytics. Smart libraries make use of a variety of technical innovations, such as the integration of artificial intelligence for enhanced search capabilities and the use of RFID technology for effective inventory management. In order to ensure accessibility and convenience for users, the study explores how digital collections, mobile applications, and augmented reality will shape libraries in the future.*

**Keywords:** Artificial Intelligence, Web platforms and Mobile applications, IoT, Virtual Learning, RFID Technology, Library Automation

## Introduction

A modern and creative spin on classic libraries, smart libraries use cutting-edge technologies to enhance and streamline a variety of library services. Automation, data analytics, Internet of Things (IoT), and artificial intelligence are some of the cutting-edge technologies that these libraries utilize to provide a more efficient, interesting, and user-friendly environment. The goal is to give patrons a more personalized and improved library experience while streamlining operations for library staff.

## Using Artificial Intelligence to Customize

AI is used to provide customized suggestions according to user history and preferences. AI algorithms are used by smart libraries to make appropriate content recommendations, event recommendations, and user experience customizations based on user demands.

## Web Platforms and Mobile Applications

Users of smart libraries may browse catalogs, reserve resources, and access library services from their PCs or cellphones thanks to the libraries' specific mobile apps or online platforms. This improves accessibility and broadens the library's audience outside its physical space.

## IoT in Smart Environments

Devices connected to the Internet of Things (IoT) have the power to create smart libraries. This comprises areas with sensor technology installed, which modifies temperature, lighting, and other environmental elements in response to human activity to provide a more cozy and energy-efficient environment.

## Virtual Learning Platforms

Smart libraries frequently have technologically-equipped collaborative learning areas that support group projects, presentations, and multimedia work. These areas meet the changing demands of professionals and students looking for technology-enhanced, interactive learning settings.

### **Repositories and Virtual Collections**

Smart libraries frequently contain a sizable digital collection of books, journals, papers, and multimedia materials. Digital repositories facilitate easy access to a wide range of items, allowing users to view and examine them remotely.

### **Barriers and Stuff to Think About**

Research addressing the obstacles libraries face in implementing smart technologies such as budgetary limitations, privacy issues, and the requirement for staff training will be highlighted in this area. There will be discussion of studies evaluating the ethical implications and long-term sustainability of smart libraries.

### **Research Needs alongside Future Paths**

The next phase aims to identify gaps in the existing research and suggest possible directions for future research. Along with these developments, it will address changing user expectations and developing technology, pushing academics to venture into unexplored territory in the field of smart libraries.

### **The Growth of Libraries in the Past**

This initial section examines the historical development of libraries, charting their journey from traditional brick-and-mortar libraries to dynamic smart libraries. It explores the factors that led to this transition and how advances in technology contributed to the modern world.

### **Digital Archives and Widely Accessible Resources**

An evaluation of the move toward digital collections in smart libraries, with a focus on user engagement, resource accessibility, and preservation. There will be a presentation of important research and conclusions about the chances and difficulties related to digitization initiatives.

### **Technology Adoption in Smarter Libraries**

An extensive analysis of the technologies influencing smart libraries, such as automation, artificial intelligence, RFID systems, and the use of open data projects. Case studies will provide examples of successful deployments and highlight how they affect user experiences and operational efficiency.

### **Automating and Robotics**

Library employees can concentrate on more intricate and involved facets of patron interaction by using robotics and auto robotics to handle repetitive duties like book retrieval, shelving, and basic customer service.

### **Cloud Computing and Remote Access**

Cloud-based solutions facilitate remote study and research by allowing users to access library resources from any location. Digital collection backup and preservation are other benefits of cloud services.

### **Working Together with Academic Institutions**

To support academic programs, smart libraries work with educational institutions in partnership. The smooth transfer of information between the library and educational activities is ensured by integration with learning management systems and academic databases.

### **Security Procedures**

Secure data storage, access management, and surveillance cameras are just a few of the security features that smart libraries offer to protect both digital and physical assets.

### **Inclusion and Affordability**

Future smart libraries will put accessibility first; making sure that the technology is built to support a wide range of user needs. This covers elements like inclusive design principles, multilingual interfaces, and assistive technologies.

### **Conclusion**

A paradigm shift in the access, management, and sharing of knowledge is represented by the transformation of libraries into smart libraries. Both user experiences and operational efficiency have been greatly improved by the incorporation of cutting-edge technology like RFID, automation, and artificial intelligence. Library resources are now more accessible than ever thanks to the digitalization of collections and the availability of mobile apps. Through the use of virtual and augmented reality technology, immersive learning environments that promote creativity and engagement have been established. Smart libraries are vital, dynamic, and adaptable parts of the modern information ecosystem in the digital age, not only information stores.

### **References**

- [1] Bill Glover/RFID Essentials/ Spd/2010
- [2] DESIDOC Bulletin of Information Technology (DBIT) Special on digital Libraries Vol.17 No.6 Year 1997.
- [3] Dink Henrici/RFID Security And Privacy/Springer/ 2010
- [4] Firke, Yogaraj S. RFID Technology for library security. In emerging technology and changing dimensions of libraries and information service by Sanjay Kataria and others. New Delhi, KBD Publication.2010
- [5] Jange, Suresh. & Angadi, Mallikarjun. (N.A). Digital Library Overview. Pp. 01-05. Retrieved From <http://eprints.rclis.org/4975/1/Digital-Library-overview>.
- [6] Jason Griffey/ Smart Libraries: Better Practices, Better Tools, Better Use of Space/ ALA Tech Source/2015
- [7] Kathleen M. Heim and Bruce Lubotsky Levin/ Emerging Library Technologies: It's Not Just for Geeks ALA Editions /2003
- [8] Marie Keen Shaw/Library Technology and Digital Resources: An Introduction for Support Staff/ Marie Keen Shaw/Libraries Limited/2009
- [9] Shalin Hai-Jew/Cloud Computing in Library Services/ Shalin Hai-Jew/2014
- [10] Smart Architecture. (2019). Smart Architecture Intelligent Project Delivery, Retrieved From <https://www.smart-arch.com>.
- [11] Watson, L. (Ed.) Better Library and Learning Space: Projects, Trends and Ideas; Facet: London, UK, 2013.



# Usage and Challenges of Citation Databases in Research and Academics

Praveen Kapoor<sup>1</sup> and Dr. Ashok Kumar Upadhyay<sup>2</sup>

<sup>1</sup>Research Scholar, <sup>2</sup>Associate Professor & Head,

<sup>1&2</sup>Department of Library and Information Science,

Mangalayatan University, Aligarh, Uttar Pradesh, India

Email: pkapoor@ddn.upes.ac.in, ashok.upadhyay@mangalayatan.edu.in

## Abstract

*The data from the citation indexes served as the foundation for citation analysis. The most significant tools for citation analysis are known as citation resources. These tools are utilized to locate references that have been mentioned in order to evaluate the significance and value of research. In recent years, citation analysis databases have emerged as a significant instrument for conducting citation analysis in educational institutions. To determine the extent of an investigation's influence and the extent to which it contributes to the existing body of knowledge, these resources are utilized to extract references and do citation analysis. Citation databases facilitate the retrieval of cited references. This tool enables users to locate, verify, and track citation data chronologically, allowing them to navigate both forwards and backwards through the literature pertaining to a specific subject. This study focuses on ascertaining the usage pattern and purpose of using various citation databases such as Google Scholar, Web of Science, and Scopus by the academicians and researchers at the University of Petroleum & Energy Studies, Dehradun. A survey questionnaire method was adopted to conduct this research, with 328 valid responses. The study also focuses on the challenges faced by users while using these citation databases. The study's findings demonstrate that users frequently use the mentioned citation databases for their research. Users are aware of different citation databases and their features and use them regularly; however, they are facing some challenges while using these resources. Online user awareness training sessions are highly preferred by users.*

**Keywords:** Bibliographic databases, Citation databases, Google Scholar, Online Database, Scopus, User Study, UPES, Web of Science.

## Introduction

Research enables scholars to enhance their knowledge in a certain domain. Researchers enhance the collective understanding of a subject by conducting systematic investigations and analysis, thereby creating new knowledge, theories, and ideas. In-depth research is essential for maintaining academic norms and establishing credibility. Thoroughly conducted research enhances the quality and credibility of academic work by ensuring that conclusions and findings are grounded in reliable evidence. A review of existing knowledge and literature is an important aspect of good-quality research.

Citation databases are essential for academic research and the exchange of scholarly information. These databases aggregate and systematize data regarding scholarly publications, comprising articles, books, conference proceedings, and other forms of academic work. Citation databases play an important role in the scientific community as they enable the discovery, assessment, and distribution of academic content. These citation databases enhance the effectiveness and efficiency of the research process, benefiting both individual researchers and the wider academic community. Web of Science, Scopus, Google Scholar, ResearchGate, and other similar databases are frequently used by scholars and academicians for citation analysis. Citation analysis is a subfield of bibliometrics that focuses on examining documents that are cited as bibliographic references or

footnotes in other documents (Levine-Clark & Gil, 2021). Citation analysis is a method employed to track and record academic research and growth within a particular domain (Kapoor & Upadhyay, 2023). Citation databases are key resources to explore existing literature and knowledge in relevant subject domains. Researchers use citation databases to identify relevant literature within their area of expertise (Naik & Pai, 2020). Scholars can locate relevant papers, journals, and books by conducting searches using key terms, authors, or subjects in particular. Academic fields are constantly changing, with new studies being regularly released. Citation databases facilitate academicians in keeping informed of the most recent advancements by offering regular updates on recently published articles and papers. Citation databases are essential in academia as they offer researchers, students, and academicians' useful resources to find, arrange, and examine scholarly information (Pratap, 2017).

Employing use and user studies has been a common method for doing research in the field of social sciences, while surveys have become an essential component of everyday life. Surveys are mostly conducted to determine opinions about a certain subject or contemporary problem or to assess the acceptability of a service or resource in the market. Surveys comprise both quantitative and qualitative aspects (A.L. Moorthy, 2015).

UPES Library subscribes to the Scopus and Web of Science Citation databases, and Google Scholar is a freely available citation database for researchers and other academic fraternities. The purpose of this study is to identify usage patterns and difficulties faced by academicians while using citation databases. Survey-based research was undertaken among library users by employing a structured questionnaire. This study will help academic fraternities use relevant resources and help decision-makers while employing resources.

### **Review of Literature**

Several research studies have analysed different aspects of online databases and / or specific citation databases, but there have been very few studies undertaken pertaining to the usage of citation databases from the user's perspective. (Kumar & Gupta, 2023) This study analyses how the library's reorganisation affected patrons use of the IIT Roorkee Library's resources and services. The findings demonstrate a rise in the utilisation of reorganised resources and services, with positive effects on users. Even though users are aware of and frequently utilise e-resources and ICT-based services and experience satisfaction with positive developments, (Kapoor & Upadhyay, 2023) This study aims to analyse the content coverage of two subscription-based citation databases, Web of Science and Scopus. The analysis reveals that these databases include different sets of indexed journals. However, around 14,917 journals are found to be common and overlap between the two databases. Analyse the similarities and differences between the two citation databases.

(Giri & Chakravarty, 2021) in his research reflects the current scenario for Google Scholar's usage in government universities in India's LIS departments and library and information science faculties. This research found that just 57% of LIS faculty maintain an active Google Scholar profile. Only 7% of faculty members keep their Google Scholar account current, and 36% don't even have a Google Scholar account. The nonexistence of a Google Scholar account impacts faculty members research output, leading to inaccuracies in the NIRF institutional rating process. (Naik & Pai, 2020) In his study, we aim to learn how often and in what ways citation databases are used. Researchers also determined why citation databases were used, how well users understood the databases' many capabilities, and how to use the databases' search tools. The researcher performed a survey employing a well-designed questionnaire; 60 were sent out and 52 replies were collected. Researchers found that a large majority (96%) of respondents were familiar with

citation databases such as Scopus, Web of Science, Google Scholars, and Research Gate. According to the findings, most users rely on citation databases to find recent literature and information in their field. About half of those surveyed are pleased with the functionality and search options provided by paid citation databases.

(Thoma & Chan, 2019) In his study, he explores the feasibility of using Google Scholar profiles to track scholarly output across various research groups. This study shows that Google Scholar tracked five diverse study groups for 6–36 months. The groups ranged in size (8–60 researchers) and prolificacy (citation counts 1006–58,380, h-indexes 19–101), with different organisational structures and aims. (Mohan et al., 2018) His research determines Google Scholar's purpose, attributes, qualities, and search methods. This survey-based research sampled 150 full-time University of Kerala researchers using a structured questionnaire. All researchers are aware of Google Scholar and its features, and over 66% regularly utilise it for literature reviews for their studies. Google Scholar search functionality and coverage were praised by 74% of respondents.

(Arumugam & Prakash, 2017) This study examines the benefits and drawbacks of Microsoft Academic vs. Google Scholar for scholarly publications. A study has found that Google Scholar is a more user-friendly citation database than Microsoft Academic, mostly due to its extensive collection of academic literature. (Pratap & Prasad, 2017) Assessed the utilisation of Web of Science, researchers' proficiency with the WOS interface, challenges encountered, and academics' satisfaction with the platform. This study utilised a survey approach to gather data from 250 research scholars at the Institute of Science, Banaras Hindu University. A structured questionnaire was employed, and random selection procedures were used to choose participants. Out of the 250 scholars, only 195 submitted their responses. A study has found that 68.7% of scholars utilise the Web of Science (WOS) database, while 31.3% of scholars do not utilise this database. 55.9% of academics use this database for the purpose of conducting literature searches, while 27.7% of scholars utilise it to stay informed about the latest trends and developments in their respective fields. Two-thirds of researchers advocate for user awareness training to enhance utilisation of the Web of Science platform.

(Tella *et al.*, 2017) His study examined Google Scholar's usefulness among postgraduate students at the University of Ilorin, Nigeria. 223 PG students and 15 faculty members were surveyed. Most people agree to utilise Google Scholar, but a minority disagree. Research showed that 38.1% strongly agree and 53.8% agree that Google Scholar search results are satisfactory. (Prasad & Pratap, 2014) studied the aim of utilising Google Scholar, familiarity with its features, challenges, and scholar satisfaction. This survey-based study distributed 140 questionnaires to researchers at the Institute of Science, Banaras Hindu University, using random sampling. Of the 97 respondents, 75 were analysed. Research showed that 82.7% of scholars use Google Scholar, while 17.3% do not. 26.7% of scholars use Google Scholar for research metrics and 62.7% for article searches. Also, 74.7% found Google Scholar useful. 64% of researchers advocate for the training needed for Google Scholar.

(Wu & Chen, 2014) This study examines the attitudes and behaviours of graduate students towards Google Scholar. Research indicates that students prefer the convenience of using Google Scholar compared to the databases offered by the library. However, students prioritise the quality of papers obtained from library databases above those found on the Google Scholar platform. (Cothran, 2011) Determine approximately 60% of the variation in graduate students' intentions to utilise Google Scholar. This study suggests that a deeper understanding of the factors that influence graduate students' adoption of new technologies for academic research purposes shows that traits like greater loyalty, perceived usefulness, and perceived ease of use have a significant

impact on students' intention to use these technologies. (Jacsó, 2005) In his paper "Google Scholar: The Pros and Cons," he discusses the benefits and drawbacks of different aspects of Google Scholar. A study shows that Google Scholar now has significant gaps in its material but anticipates that with future modifications to its framework, it will evolve into a valuable and cost-free resource for discovering and accessing scholarly information. According to a review of past studies, the user study of citation databases at the University of Petroleum and Energy Studies (UPES), Dehradun, has not been the subject of any research investigation till now.

### **Objective of Study**

The present research study was conducted among users with the following objectives:

1. To know the usage patterns of different citation databases.
2. To ascertain the purposes of using citation databases.
3. To ascertain challenges encountered while using citation databases.

### **Importance of the Study**

Citation databases are significant resources for research studies, and scholars and other users extensively utilize various citation databases for various purposes. University of Petroleum and Energy Studies Dehradun subscribes to subscription-based citation databases like Scopus and Web of Science, and library users also have access to different open-access citation databases like Google Scholar, ResearchGate, etc. This is an area where no prior research has been conducted, and the findings of the study can be used to improve the quality, access, and service of the library. This study aims to analyse the trends and usage patterns of citation databases, as well as the challenges experienced by researchers and other users when accessing these resources.

### **Methodology**

This study is based on the data collected through the survey method among university library users. A well-structured questionnaire using a Likert scale was designed to collect data in view of the above-mentioned objectives of the study. The questionnaire contains various questions pertaining to the use of citation databases. The total population for this study consists of faculty members, research scholars, and students at the university. A self-administered survey questionnaire was distributed in hybrid mode, which included a print questionnaire as well as an online survey questionnaire via Google Form, and follow-ups through personal visits, phone calls, email, and WhatsApp were made to collect the responses. Additionally, the interview and discussion methods were adopted to know the viewpoints of the users of citation databases.

### **Analysis of Data**

Data on the use of citation databases was collected based on a survey questionnaire distributed to and responded to by library users at the University of Petroleum and Energy Studies. The collected data were analysed with the help of MS Excel and the statistical package SPSS 24.0. Suitable statistical techniques and tools, including frequency count, percentage, mean, and standard deviation, were employed for data analysis purposes. A total of 362 responses were received through the online and offline survey forms, and of the 328 valid responses received, 32 filled-out survey forms were found incomplete and hence rejected.

### **Distribution of the Respondents**

Respondents' preferences are significantly impacted by demographic characteristics. Figure 1 (A) and (B) present the composition of the respondents; out of 328 respondents, 194 are male and 134 are female. Additionally, the respondents are categorised based on their academic status, with 84 being faculty members, 103 research scholars, 41 postgraduate students, and 100 undergraduate students.

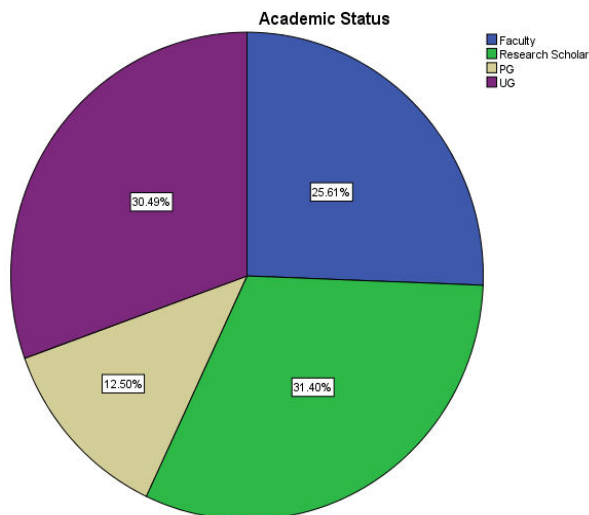

Fig 1 (A) Academic Status

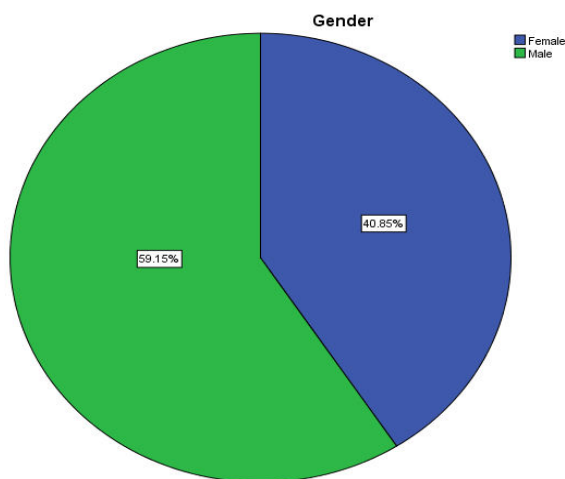

Fig 1 (B) Gender

### Use of Citation Databases

Respondents were asked to specify the regularity of their usage of the citation databases named Web of Science, Scopus, and Google Scholar on a five-point Likert scale and specify the name of any other citation databases if they use them in addition.

Table I indicates how often the respondents use the mentioned citation databases; 48% of respondents always use Google Scholar, and 27.7% of respondents usually use Google Scholar as this is a freely available open-access citation database, and the results indicate Google Scholar is a well-known resource among respondents. The results also indicate that 39.3% of respondents always used Scopus, whereas 26.8% usually used Scopus. 30.8% of respondents always used the web of science, and 26% usually used the web of science. The chart indicates 13.7% never used Web of Science, 11% never used Scopus, and 3.4% never used Google Scholar.

TABLE I USE OF CITATION DATABASES

Frequency	Web of Science		Scopus		Google Scholar	
	No.	%	No.	%	No.	%
Always	101	30.8	129	39.3	158	48.2
Usually	85	25.9	88	26.8	91	27.7
Occasionally	57	17.4	42	12.8	54	16.5
Rarely	40	12.2	33	10.1	14	4.3
Never	45	13.7	36	11.0	11	3.4
Total	328	100.0	328	100.0	328	100.0

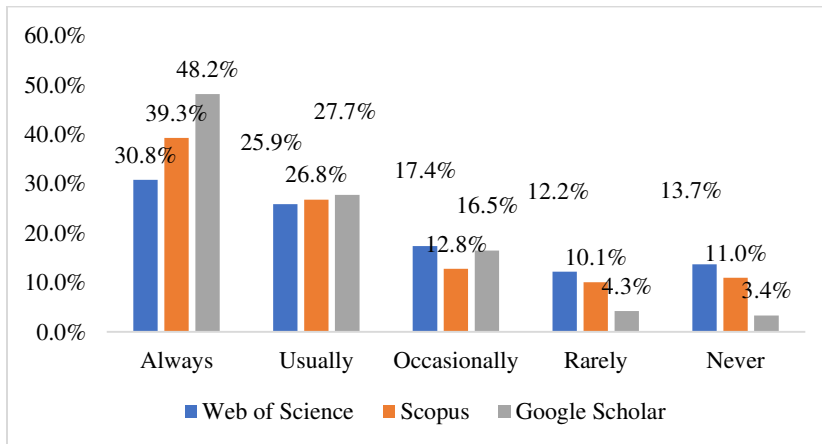

Fig 2 Usage Pattern of Citation Databases

Table II shows descriptive statistics: Mean and Standard Deviation of use of different citation databases, such as Web of Science, Scopus, and Google Scholar, and the analysis result show that respondents are aware of and use all three citation databases. The study also reveals that respondents also use other citation databases, such as the Indian Citation Index, ResearchGate, etc.

TABLE II STATISTICS - USE OF CITATION DATABASES

Citation Databases	N	Mean	Std. Deviation
Web of Science	328	3.48	1.392
Scopus	328	3.73	1.359
Google Scholar	328	4.13	1.051

### Purposes for using Citation Databases

Respondents were asked to indicate the purpose of their usage of the different citation databases. Analysis of the collected data revealed that the majority of the respondents (79.3%) are using them for research purposes, and 48.8% of respondents are using them for learning purposes. 14.6% use it for teaching purposes, and only 11% use it for grant proposal writing purposes. The study reveals that citation databases are widely used for research purposes. Researchers use these citation databases for literature searches, to know current trends and developments in their subject domain, and to collaborate with peers. The chart clearly indicates that the majority of the respondents are not using citation databases for grant proposal writing, and during interaction with

the respondents, it was observed that they were not aware of all the features of the citation databases. It is observed that there is a lack of awareness among respondents that citation databases can be used to identify funding agencies in their research domain.

TABLE III PURPOSE OF USING CITATION DATABASES

	Research		Learning		Teaching		Grant Proposal Writing	
	No.	%	No.	%	No.	%	No.	%
Yes	260	79.3%	160	48.8%	48	14.6%	36	11.0%
No	68	20.7%	168	51.2%	280	85.4%	292	89.0%
Total	328	100.0	328	100.0	328	100.0	328	100.0

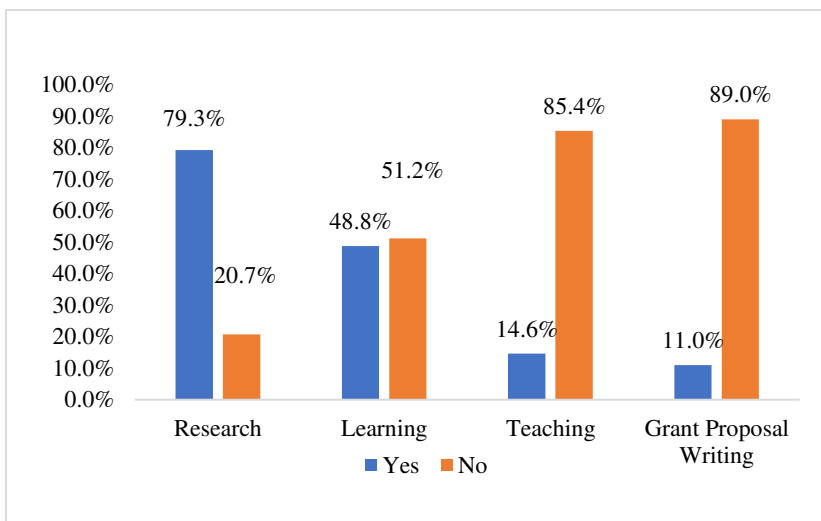

Fig. 3 Purpose of Using Citation Databases

### Challenges encountered while using Citation Databases

To establish the different challenges faced by the respondents while using citation databases, respondents were asked to exhibit their responses by selecting different statements on a five-point Likert scale, starting at 5 for strongly agree and 3 for neutral. Table IV shows the challenges faced by the respondents when using different citation databases. 31.7% of respondents agree or strongly agree with the statement that they are not getting relevant results, whereas 33.6% of respondents disagree with the statement, and 34.8% are neutral. In answer to the following statement, 30.4% of respondents agree or strongly agree with the statement that citation databases provide inaccurate search results, 39.1% disagree or strongly disagree, and 30.5% remain neutral. 28.3% agree with the statement about inappropriate content coverage of citation databases; more than 41% disagree with the statement; and 30.5% are neutral. Further, in response to the statement, Lack of awareness about content coverage 31.1% agree or strongly agree, whereas 32.3% disagree, and 36.6% are again neutral on the mentioned statement. More than 35% of respondents are lacking in the access mechanism of citation databases, meaning they are not aware of how to access these databases, whereas 35.4% disagree or strongly disagree with the statement, and 29% are still neutral. 46.3% of respondents are unable to find full-text documents with the help of these databases, and more than 20% of respondents are able to access full text, while one third of the respondents remain neutral on the statement Inaccessibility of full-text documents through citation databases. Retrieval of full-text documents from citation databases depends on the subscription of

relevant resources by the concerned institution or if the resource is open access, as citation databases primarily provide bibliographic and citation details of any documents. The chart clearly reveals that one-third of the respondents are neutral on the various statements pertaining to challenges encountered while using citation databases.

TABLE IV CHALLENGES ENCOUNTERED WHILE USING CITATION DATABASES

Particulars	Strongly Agree		Agree		Neutral		Disagree		Strongly Disagree		Total	
	No.	%	No.	%	No.	%	No.	%	No.	%	No.	%
Do not get relevant result	36	11.0%	68	20.7%	114	34.8%	94	28.7%	16	4.9%	328	100.0%
Inaccurate search results are provided	30	9.1%	70	21.3%	100	30.5%	116	35.4%	12	3.7%	328	100.0%
Inappropriate content coverage of citation databases	27	8.2%	66	20.1%	100	30.5%	109	33.2%	26	7.9%	328	100.0%
Lack of awareness about content coverage	31	9.5%	71	21.6%	120	36.6%	84	25.6%	22	6.7%	328	100.0%
Lack of knowledge of the access mechanisms	43	13.1%	74	22.6%	95	29.0%	98	29.9%	18	5.5%	328	100.0%
Inaccessibility of full-text documents	50	15.2%	102	31.1%	108	32.9%	58	17.7%	10	3.0%	328	100.0%

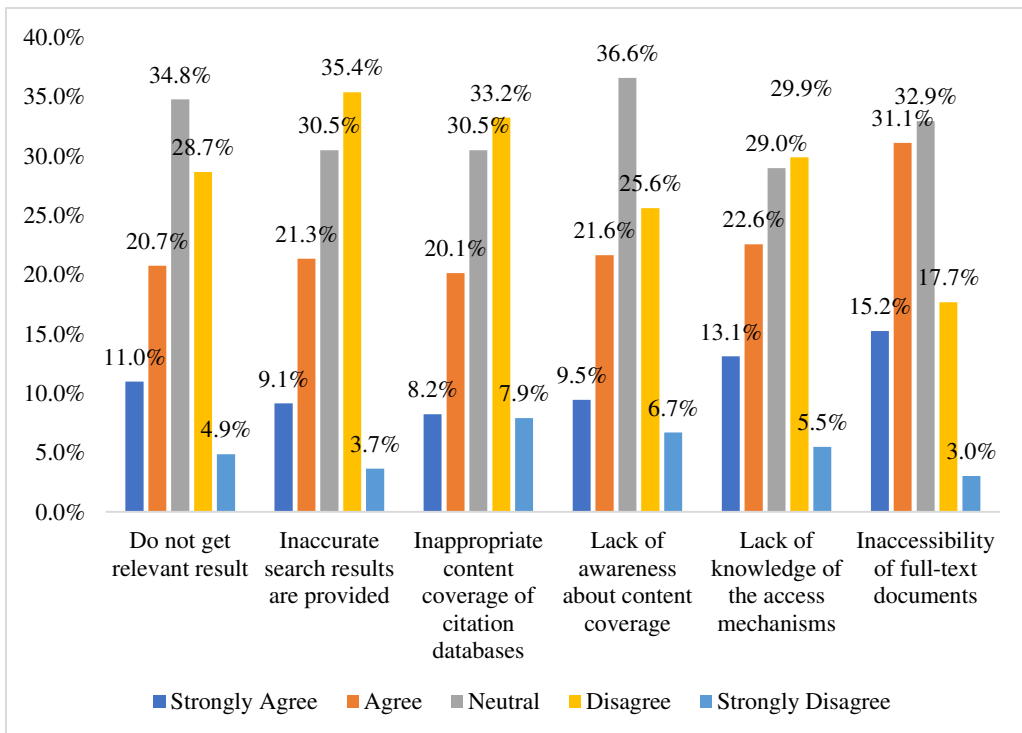

Fig. 4 Challenges Encountered While Using Citation Databases



Table V shows descriptive statistics, which include the mean and standard deviation (SD) of various statements on challenges encountered while using citation databases, and analysis indicates that respondents have a mixed response and are neutral on the challenges encountered while using citation databases.

TABLE V STATISTICS - CHALLENGES ENCOUNTERED WHILE USING CITATION DATABASES

Descriptive Statistics	N	Mean	Std. Deviation
Do not get relevant result	328	3.04	1.063
Inaccurate search results are provided	328	2.97	1.040
Inappropriate content coverage of citation databases	328	2.88	1.081
Lack of awareness about content coverage	328	3.02	1.059
Lack of knowledge of the access mechanisms	328	3.08	1.125
Inaccessibility of full-text documents	328	3.38	1.039

### User Awareness Session or Training Required for Effective Utilisation of Citation Databases

According to Table VI, 66.8% of the respondents believe that user awareness sessions are necessary for efficient use of citation databases, whereas 33.2% do not require any form of training or session for awareness.

TABLE VI NEED OF USER AWARENESS SESSION OR TRAINING

Need of User	Frequency	Percent
Yes	219	66.8
No	109	33.2
Total	328	100.0

### Preferred Method for Conducting the User Awareness Sessions or Training

According to Table VII, 61.3% of the respondents preferred to have online user awareness sessions, whereas 38.7% preferred to have offline user awareness sessions or training.

TABLE VII PREFERRED METHOD FOR USER AWARENESS SESSIONS OR TRAINING

Preferred Method	Frequency	Percent
Online mode	201	61.3
Offline mode / On-site	127	38.7
Total	328	100.0

### Major Findings

The conclusions derived from the analysis of the data are summarised below.

1. The majority of the users (75.9%) use Google Scholar as a citation database regularly, followed by 66.2% using Scopus and 56.7% using Web of Science. Only 7.6% of users rarely used or never used Google Scholar, whereas 21% never used or rarely used Scopus, and 25% never used or rarely used Web of Science.
2. In addition to Google Scholar, Scopus, and Web of Science, library users also use other citation databases like the Indian Citation Index and ResearchGate.
3. The majority of users use citation databases for research purposes, followed by learning and teaching purposes. Very few users use citation databases for grant proposal writing or tracing funding agencies.

4. Regarding the challenges faced by the user while using citation databases, one-third of users are neutral, and more than one-third of users disagree with the challenges.
5. Two-thirds of users require training and user awareness sessions for better utilisation of the citation databases, and most of the users prefer to have online training or user awareness sessions.

### Conclusion

The quick advancement and deployment of technology have significantly improved the acquisition of necessary information and helped in the optimum utilisation of available resources to finish research work on time. Online library resources are the key tools of today's research activities, and citation databases are widely used by researchers and the academic fraternity. Citation databases help researchers in literature search and review existing knowledge. These databases help researchers and academicians to know the current trends and work done so far in their research area, help in collaboration with peers, and trace funding agencies. Citation databases also help in tracking citation information. This research study shows that academicians, researchers, and the scholarly fraternity widely use different citation databases such as Google Scholar, Scopus, and Web of Science regularly, and the majority of the users use different citation databases for research purposes. Library users are well aware of these citation databases; however, user awareness sessions are required to make people more aware of the different features and functionalities of these resources. The UPES library subscribes to the Scopus and Web of Science citation databases, along with various full-text e-resources. Faculty members and research guides need to take the initiative to enhance awareness among scholars and students.

### Reference

- [1] A.L. Moorthy. (2015). A Critical View of User Studies. *Journal Of Indian Library Association*, 51(4), 4–11.
- [2] Arumugam, J., & Prakash, M. (2017). A study on Microsoft academic search and Google scholar: A gateway for researchers. *International Journal of Multidisciplinary Research and Development* [www.Allsubjectjournal.Com](http://www.Allsubjectjournal.Com), 4(2007), 41–47. [www.allsubjectjournal.com](http://www.allsubjectjournal.com)
- [3] Cothran, T. (2011). Google Scholar acceptance and use among graduate students: A quantitative study. *Library and Information Science Research*, 33(4), 293–301. <https://doi.org/10.1016/j.lisr.2011.02.001>
- [4] Giri, S., & Chakravarty, P. R. (2021). Google Scholar Adoption by LIS Educators in India: An Exploratory Study. *Library Philosophy and Practice*, 2021, 1–27.
- [5] Jacsó, P. (2005). Google scholar: The pros and the cons. *Online Information Review*, 29(2), 208–214. <https://doi.org/10.1108/14684520510598066>
- [6] Kapoor, P., & Upadhyay, A. K. (2023). Comparative Study of Citation Databases: Web of Science & Scopus. *Empowering Libraries, . Connecting Communities Lnnovation, Collaboration A-nd Entrepreneurship*, 212-223p.
- [7] Kumar, R., & Gupta, D. K. (2023). Impact of restructuring resources and services and their utilization in IIT Roorkee library, India. *Library Management*, 44(3–4), 217–228. <https://doi.org/10.1108/LM-03-2022-0017>
- [8] Levine-Clark, M., & Gil, E. L. (2021). A new comparative citation analysis: Google Scholar, Microsoft Academic, Scopus, and Web of Science. *Journal of Business and Finance Librarianship*, 26(1–2), 145–163. <https://doi.org/10.1080/08963568.2021.1916724>
- [9] Mohan, G. P., Rajan, J. S., & Kabir, S. H. (2018). Awareness and Use of Google Scholar among the Research Scholars in University of Kerala. *LIS Journal of Librarianship and Informatics*, 1(1), 49–57.
- [10] Naik, G., & Pai, R. (2020). Role of Citation Databases in Research : A Study Role of Citation Databases in Research : A Study. *Library Philosophy and Practice (e-Journal)*.

<https://doi.org/https://digitalcommons.unl.edu/cgi/viewcontent.cgi?article=8116&context=libphilprac>

- [11] Prasad, H. N., & Pratap, D. (2014). Use of google scholar among research scholars of faculty of arts and faculty of social sciences of Banaras Hindu University: A study. *Gyankosh- The Journal of Library and Information Management*, 5(2), 49. <https://doi.org/10.5958/2249-3182.2014.00010.0>
- [12] Pratap, D. (2017). *Comparative Study of Google Scholar and Web of Science from Users Perspective* (Issue 285314). <http://hdl.handle.net/10603/268445>
- [13] Pratap, D., & Prasad, P. H. N. (2017). Use of Web of Science among Research Scholars of Institute of Science , Banaras Hindu University : a Study. *Library Waves*, 3(1), 18–26.
- [14] Tella, A., Oyewole, M., & Tella, A. (2017). An analysis of perceived usefulness of Google Scholar by the postgraduate students of the University of Ilorin, Nigeria. *SA Journal of Information Management*, 19(1), 1–9. <https://doi.org/10.4102/sajim.v19i1.793>
- [15] Thoma, B., & Chan, T. M. (2019). Using Google Scholar to track the scholarly output of research groups. *Perspectives on Medical Education*, 8(3), 201–205. <https://doi.org/10.1007/s40037-019-0515-4>
- [16] Wu, M. Der, & Chen, S. C. (2014). Graduate students appreciate Google Scholar, but still find use for libraries. *Electronic Library*, 32(3), 375–389. <https://doi.org/10.1108/EL-08-2012-0102>

# Empowering Women Through E-Resources: A Comprehensive Review

Susan Babu<sup>1</sup> and Dr. A. Senthamilselvi<sup>2</sup>

<sup>1</sup>Research Scholar, Bharathidasan University, Tiruchirappalli, Tamil Nadu, India

<sup>2</sup>Librarian and Head, DLIS, Holy Cross College (Autonomous), Tiruchirappalli, Tamil Nadu, India  
E-mail: assenthamil@gmail.com

## Abstract

*This paper explores the role of electronic resources (E-Resources) in empowering women across diverse domains, including online learning platforms for marginalized girls, digital skills training for economic independence, tele health services for rural women, and online networks for feminist advocacy. In the digital era, access to information and technology facilitates gender equality and women's empowerment. By reviewing existing literature and initiatives leveraging E-Resources, the paper demonstrates that these resources have demonstrably challenged gender norms, reduced disparities, and empowered women to take agency. Notably, the paper also identifies emerging trends, such as AI-driven mentorship and virtual reality in education, that hold further promise for advancing women's empowerment in the future.*

**Keywords:** Women's empowerment, E-Resources, Education, Employment, Health, Gender Equality.

## Introduction

Encouraging women's self-worth, their autonomy, and their ability to influence social change for others is known as women's empowerment. In the rapidly evolving landscape of the digital era, the utilization of electronic resources (E-Resources) stands as a powerful catalyst for advancing women's empowerment. From education to entrepreneurship, healthcare to social activism, these digital tools and platforms have emerged as transformative agents, dismantling traditional barriers and providing unprecedented opportunities for women worldwide. This introduction sets the stage to explore the multifaceted ways in which E-Resources contribute to fostering gender equality, breaking down societal constraints, and empowering women to thrive in the modern, interconnected world.

Electronic resources (E-Resources) play a crucial role in advancing women's empowerment in various ways. The importance of E-Resources in this context lies in their ability to address and overcome traditional barriers that have hindered women's progress in education, employment, health, and social participation. For instance, women can avoid relying on information brokers or middlemen in their communities by using mobile-based public information outreach services; women can also save time by filing entitlement claims and monitoring the status of their applications; and women with disabilities or older adults who are unable to move around can receive basic healthcare through e-health services. Here we discuss about the Empowering Women through E-Resources: A Comprehensive Review.

## Review of Literature

Dhiman, Bharat (2023) studied a Critical Examination of Education's Contribution to Women's Empowerment and Gender Inequality. This review study investigates the contribution of education to gender inequality and women's empowerment. It examines the intricate connections between gender equality, women's empowerment, and education, stressing both the achievements and ongoing difficulties. In this paper, gender differences in educational opportunities are discussed, along with the ways that education can empower women and the obstacles that educational

systems must overcome to keep gender inequality alive. Additionally, it looks at ways to advance gender equality in the classroom and provides case studies and success stories to show how interventions work. The effectiveness of these interventions is critically examined, problems that still need to be solved are noted, and suggestions for further action are made in the paper's conclusion.

Crompton, H. & Tabasum Niroo, W., (2022) examined Women's Empowerment through Learning Using Technology. Around the world, people's lifestyles have been influenced by technology. Currently, most of the world's people use technology as a gateway to learning with the abundance of learning resources available to them. Learning can be accessed by women in developed and developing nations via technology, yet academics do not have a consensus on an updated understanding of how technology is being utilized to offer educational resources for global women's empowerment. For that reason, this investigating the body of existing empirical work, the systematic review included an aggregated and qualitative synthesis, five years, from 2017 to 2021. There were forty articles included after a strict PRISMA selection process. In the end, derived from 80 nations. The results show that most (60%) of the studies were conducted. Africa's Sub-Saharan Region. Five industries emerged as areas that provided grounded coding. Empowerment through the course materials in the areas of entrepreneurship, health, agriculture, and the environment exchange of ideas. The three main domains of health, communication, and empowerment for women were Business ownership. Information from this study is useful for advocates, legislators, funders, and women. This study identified topics that warrant further investigation, such as more thorough reviews to investigate academic publications written in languages other than English and gray literature not published in scholarly journals in languages.

### **Scope of the Study**

Women's empowerment is essential to the family, community, and national economic and social development. When women lead safe, happy, and fulfilling lives, they can reach their full potential. Utilizing their skills in the workforce and being able to raise more contented and healthy children. They can also advance humankind overall, improve societies, and encourage sustainable economies. Education is a crucial component of this empowerment. Education enables girls to pursue fulfilling careers that will eventually boost the economy of their nation. In addition, after eight years of education, they are four times less likely to marry young, which is advantageous for both their own and their families' health.

### **Objectives of the Study**

1. Discuss the role of E-Resources in promoting women's access to education, including digital libraries, and educational platforms;
2. Analyze how digital health resources contribute to women's well-being and healthcare access;
3. Evaluate existing government policies and initiatives that support the integration of E-Resources for women's empowerment;
4. Identify challenges associated with the implementation of E-Resources for women's empowerment;

### **Examine E-Resources in Education**

Here are some ways e-resources can help women access education:

1. *Online Education:* Online education can provide formal and informal learning opportunities for learners. Women can use updated information and knowledge resources to make positive changes in their lives.

2. *Digital Technology*: Digital technology can help address educational challenges and reach more learners, including women and other marginalized groups.
3. *Information and Communication Technology (ICT)*: Women can have greater access to training resources, continuing education, and lifelong learning with the help of ICT.
4. *Digital Libraries*: Digital libraries can manage, store, and retrieve books, audio files, image files, video files, and magazine articles. Books and journals can be obtained for free from e-libraries.

### **Use of E-Resources in the Healthcare Sector**

The use of digital health technology has transformed healthcare delivery in recent years. Technology is improving access to and convenience of healthcare, particularly for women, with the help of telemedicine, wearable and health apps. Women can receive private and convenient healthcare consultations in the comfort of their own homes. It is often stigmatized for women to talk openly about issues related to menstruation, sexuality, and reproductive health. In a discreet and welcoming environment, online consultations allow women to discuss these touchy subjects without worrying about criticism or humiliation. This also saves money and time by removing the need for travel.

### **Government of India Initiatives for Women Empowerment**

With a variety of planned interventions, the Indian government has made a number of efforts to guarantee women's social, educational, economic, and political advancement. Government initiatives include the National Social Assistance Programme (NSAP), the Pradhan Mantri Awas Yojana (Urban and Rural), and others like Samagra Shiksha, the Scheme of National Overseas Scholarship, Babu Jagjivan Ram Chhatrawas Yojna, Swacch Vidyalaya Mission, etc., Agreement that schools are welcoming to girls, particularly those from disadvantaged backgrounds, and have the necessary infrastructure to meet their unique needs.

Moreover, gender equity is given top priority in the National Education Policy (NEP), 2020, with an emphasis on socially and economically disadvantaged groups (SEDGs), which seeks to ensure all students equitable access to high-quality education.

The government provides women workers with access to a network of training institutions called Women Industrial Training Institutes, National Vocational Training Institutes, and Regional Vocational Training Institutes, with the aim of improving their employability. The government also ensures women's economic independence through the Skill India Mission, which offers skill development and vocational training. The National Skill Development Policy prioritizes inclusive skill development and attempts to boost women's participation in order to increase economic productivity. Some of the main areas of focus for Pradhan Mantri Kaushal Vikas Kendras are a gender-sensitive and safe training environment, hiring female trainers, fair compensation, and complaint resolution procedures. Other areas of focus are the development of more infrastructure to support women in pursuing apprenticeships and training programs, adaptable methods for delivering training, and afternoon training sessions on locally needed training that are specifically designed to accommodate women. Women entrepreneurs are served by programs like Stand-Up India, which is also known as the Pradhan Mantri Mudra Yojana, and the Prime Minister's Employment Generation Programme (PMEGP). In order to safeguard women's health, the Pradhan Mantri Ujjwala Yojna (PMUY) provides them with clean cooking fuel and relieves them of the strenuous task of gathering firewood.

To further empower women and girls in the nation, the Ministry of Women and Child Development (MWCD) has implemented the following programs over the past five years:

1. POSHAN Abhiyaan
2. Anganwadi Services Scheme
3. Pradhan Mantri Matru Vandana Yojana (PMMVY)
4. Beti Bachao Beti Padhao (BBBP) Scheme
5. One-Stop Center (OSC)
6. Universalization of Women Helpline
7. Child Protection Services Scheme
8. Scheme for Adolescent Girls (SAG)
9. Swadhar Greh Scheme
10. Ujjawala Scheme
11. Working Women Hostel

Additionally, the Central Government is implementing a number of projects and schemes through various Ministries, Departments, and Implementing Agencies under the Nirbhaya Fund. These include the Emergency Response Support System (ERSS), a mobile app-based and single-number (112) system for emergencies across India; a cybercrime reporting portal for reporting obscene content; Safe City Projects in eight cities (Ahmedabad, Bengaluru, Chennai, Delhi, Hyderabad, Kolkata, Lucknow, and Mumbai) that include infrastructure, technology adoption, and capacity building in the community through awareness campaigns and training and skill development programs for investigators, prosecution officers, and medical officers; distribution of Sexual Assault Evidence Collection (SAEC) Kits to States/UTs; and the establishment of State-of-Art DNA.

As compared to NFHS-4, the National Family Health Survey-5 (NFHS-5) results show that women's status has improved over the past five years in a number of areas, demonstrating the beneficial effects of the government's above-mentioned initiatives. Over 78.6% of women now have bank accounts that they use for personal use, a 25% increase over the previous five years. This suggests that three out of every four women have personal bank accounts. As compared to 46% five years ago, 54% of Indian women, or one in every two, now own and use a mobile phone. Five years ago, only 38% of Indian women owned a home or plot of land; today, 43% of women own either individually or jointly. According to NFHS-5 data, the sex ratio has improved. Nowadays, women run and lead one in five non-farm businesses.

Our society is changing more and more to the point where men value the opinions of women as partners in the home. Nowadays, a greater number of women take part in important home decisions. According to NFHS-5 data, 88.7% of women now take part in important household decisions, up from 84% five years ago. Over the previous ten years, there has been a significant decline in the prevalence of domestic violence. Compared to 39% and 33%, respectively, ten and five years ago, only 29% of married women now report having experienced spousal violence, according to NFHS-5 data.

### **Challenges Faced in Implementing E-Resources for Women's Empowerment**

In earlier times, women faced a variety of challenges, such as child marriage, sati pratha and parda pratha, limitations on widow remarriage, widow exploitation, the devadasi system, etc. But nearly all of the traditional, old problems have progressively vanished from society, making room for new ones. Even with their greater capacity, talent, individuality, self-respect, personality, self-

confidence, and efficiency compared to men, women still deal with a lot of issues on a daily basis. They have issues in their day-to-day lives.

Here are a few of the main issues that contemporary women continue to face:

*1. Violence against Women:* Nearly every day, women are impacted by different types of violence, which is upsetting society. The Central Home Ministry's Crime Record Bureau report states that as crimes against women rise, women are becoming victims of violence on a massive scale on a daily basis. Every day, 17 women die from dowry-related causes; they are kidnapped every 44 minutes, raped every 47 minutes, etc. They may encounter both internal and external forms of violence, including but not limited to death, spousal rape, physical abuse, sexual abuse, starvation, and inheritance-related harassment. Kidnapping, rape, murder, and attacks are a few instances of external violence.

*2. Gender Discrimination:* Girls' children are becoming real beneficiaries of the discrimination against women since they are viewed as a weaker part of society than men and are considered to have less value. Because Indian families are patriarchal, there is also discrimination against women in positions of authority and at work. Gender discrimination for women affects many areas, such as jobs, public life, education, health, care giving, the decline of the female population, and nutrition.

*a) Issues with Women's Education*

The number of educated women in India is low, especially in rural areas, as a result of the discouragement of women from pursuing higher education, including professional and technical education.

*b) Unemployment-Related Issues*

Finding suitable work is becoming more difficult for women. They are more vulnerable to harassment and exploitation at work.

*c) Boss Intentionally*

Their supervisor purposefully assigns them more work and challenging assignments, and they are occasionally required to demonstrate their commitment, honesty, and loyalty in their job.

*d) Unbearable Conditions*

Throughout their lives, illiterate women are more likely to experience divorce and husband rejection. They are forced to fear divorce for the rest of their lives. Because of intolerable circumstances, they occasionally have to take their own lives.

*e) Growing*

Another major issue facing women in society that is getting worse every day is the dowry system. Women are harassed, manhandled, humiliated, tortured, and subjected to other cruelties (violence, murder, and suicide) because there is no dowry at the time of marriage. The status of women is greatly diminished as a result of it.

## **Emerging Trends in E-Resources for Women's Empowerment**

Emerging trends in E-Resources for women's empowerment were already shaping the landscape.

*1. Digital Mentor ship Programs:* Online mentor ship platforms and applications were becoming popular, providing women with opportunities to connect with mentors across the globe.

*2. AI-Powered Career Guidance:* Artificial Intelligence (AI) and machine learning algorithms were being employed to provide personalized career guidance and skill development recommendations for women.



3. *Virtual Reality (VR) for Education and Training*: The integration of virtual reality in educational E-Resources was expanding, offering immersive learning experiences.

4. *E-Health Platforms with AI Diagnosis*: E-Health platforms were integrating artificial intelligence for preliminary health diagnosis, offering convenient and accessible healthcare services.

These emerging trends indicate a dynamic and evolving landscape for E-Resources in women's empowerment, leveraging advanced technologies to address specific challenges and create more inclusive opportunities. Ongoing developments in these areas are likely to continue shaping the future of digital empowerment for women.

### **Conclusion**

"E-Resources for Women's Empowerment" encapsulates a multifaceted approach to leveraging digital tools and platforms to enhance the status, opportunities, and well-being of women. The transformative potential of E-Resources lies in their ability to reshape the narratives surrounding women's roles in society, providing tools and opportunities that empower women across various domains. As technology continues to advance, the impact of E-Resources in advancing women's empowerment is likely to grow, bringing about positive and lasting changes.

### **References**

- [1] Dhiman, Bharat, 2023, Education's Role in Empowering Women and Promoting Gender Inequality: A Critical Review. SSRN. <http://dx.doi.org/10.2139/ssrn.4556375>
- [2] Retrieved from: <https://universalinstitutions.com/government-of-india-initiatives-for-women-empowerment/>
- [3] Retrieved from: <https://www.smilefoundationindia.org/blog/women-empowerment-needs-digital-empowerment/>
- [4] Retrieved from: <https://www.worldvision.com.au/womens-empowerment/>
- [5] Tabasum Niroo, W., and Crompton, H., 2022. Women's Empowerment through Learning Using Technology. Asian Society for Open and Distance Education (ASODE), 17 (2), 135 - 152. <http://www.asianjde.com/>.

# Digital Privacy in University Libraries in Kerala

Aparna Nair<sup>1</sup> and Dr. B. Mini Devi<sup>2</sup>

<sup>1</sup>Student, Dept. of Library and Information Science, University of Kerala, Kerala, India

<sup>2</sup>Assistant Professor & Former Head,

Dept. of Library and Information Science, University of Kerala, Kerala, India

E-mail: aparnahari97@gmail.com, drminidevi1968@gmail.com

## Abstract

*This paper explores digital privacy awareness of library professionals in four university libraries in Kerala. The methodology adopted for the study was survey research method and questionnaire method was adopted for data collection. The study also assesses the data privacy practices implemented by the libraries. Majority of the library professionals has knowledge about digital privacy and data protection. Most of the library professionals are aware of issues related to virus, malware attacks, improper data backups, unauthorized access, theft and damage of data that can affect information stored by library.*

**Keywords:** Data Privacy, Digital Privacy, Identity Theft, Internet, Library Professionals, Online Privacy, Personal Data, University Libraries.

## Introduction

Data Privacy Day (DPD) is observed on January 28 all around the world and its main goals were sensitizing people and spreading information about privacy practises and values. For fostering a culture of privacy, this day encourages everyone to take ownership of their privacy obligations.

The year 2022's theme was "Privacy Matters" which fosters a sense of responsibility by demonstrating the importance of privacy in everyone's life. People need to be more aware of it and responsible with their data. Data Privacy issues became pertinent during the pandemic when most of the people were forced to spend time and conducted financial transactions in the online world.

Library is a non-profit organisation which aims to provide user community reliable, pin pointed information in a short time. It is not just the mere services, but also humanitarian rights and privileges are also provided to the user community. Such rights like privacy have very much importance from the earlier times. "All people, regardless of origin, age, background or views, possess a right to privacy and confidentiality in their library use. (The Library Bill of Rights, Article VII).

Libraries have significant power to advocate for, educate about and protect people's privacy safeguarding all library use data, including personally identifiable information. "Privacy is essential to the exercise of free speech, free thought, and free association. Lack of privacy and confidentiality chills users' choices, thereby suppressing access to ideas. The possibility of surveillance, whether direct or through access to records of speech, research and exploration, undermines a democratic society"(Privacy: an interpretation of Bill of Rights).

The concept of Digital Privacy has very much significance in the current technological development scenario. Like any other field, libraries are also transforming its services from traditional to digital mode thus by facing unseen threats and problems never faced before. Along with providing reliable information to the user community, library also have a great responsibility in protecting the personal data they provided to libraries in different occasions and protection of their reading history and web browsing from disclosing to public and third-party vendors.

Digital Privacy also called as online privacy is the concept of transmitting information, data, messages, and files via the internet without disclosing it to unauthorized parties. It involves maintaining control over information about a person or an institution. It is the act of browsing the internet covertly without disclosing or exposing personal data. It can be used in a variety of settings, including data, messages, and private communications. A variety of techniques and technologies are used to safeguard confidential data and communications from being leaked to the public in order to realize this notion. Data protection online is essentially what digital privacy is about.

Due to the increased use of technological devices the difference between data collection, storage and processing are disappearing rapidly. Indeed, the users may have low awareness on when, how and where these processes happen. The privacy concerns posed by information technology includes, the amount of information collected by digital devices and environments, the speed with which information can be shared, length of storage time and the type of information that can be collected (Tavani, 2008).

The issues of patron privacy and confidentiality are core to the ethics, norms and traditions of libraries. The foundation of intellectual freedom is the right to privacy, which is the ability to read, consider, and form ideas and opinions without being observed or subject to unwanted surveillance by the government or others. Because it allows library users to choose, access, and analyse information and ideas without worry of shame, judgement, punishment, or ostracism, privacy is crucial to free inquiry in the library. Lack of privacy in what one reads and views in the library can significantly deter patrons from using their First Amendment right to read, limiting free access to ideas. Both a wide range of materials and the assurance that one's selections are not being watched are necessary for true freedom of choice at the library.

Over the past ten or so years, technological advancements have caused a boom of digital libraries. Regardless of a person's location, these present useful opportunities for easy access to information and data. However, the switch from physical to digital library collections presents numerous additional difficulties for librarians, not the least of which are those related to security and privacy. The safety of the information infrastructure and end users' privacy must both be prioritised at the same time. There are numerous privacy and security concerns relating to both library patrons and digital materials as a result of the global expansion in information volume and the digital devices on which it is kept. In order for libraries to continue playing their vital role of providing users with accurate, secure, and timely information while safeguarding their privacy and the confidentiality of their personal information, it is important to examine the nature of these challenges and the opportunities available for overcoming them. Without individual privacy there is no meaning to the individual's life.

### **Review of Literature**

Eroğlu & Çakmak in the year 2020 carried out a study on Personal data perceptions and privacy in Turkish academic libraries pointed out the recent expansion of data sharing options enabled by technology has led to an increase in concerns about the privacy of personal data. The study, designed after a situational research study, aimed to assess the attitudes of university library directors toward the privacy and security of personal data. The study gathered information from the directors of 16 university libraries in Turkey. The findings revealed some gaps in the administrations of university libraries' knowledge and perception of the privacy of personal data and the study concludes with possible suggestions for development in this area.

Hartman-Caverly & Chisholm in the year 2020 examined privacy and privacy literacy (PL) instruction in academic libraries in the past, present, and future. The study reviewed the research in the fields of philosophy, anthropology, history, law, education, and LIS on privacy and privacy literacy.

The study suggests using a privacy conceptual model to illustrate the informational agency zones that privacy protects, and privacy and libraries chronology outlines significant changes to US privacy culture throughout time. Discussion follows the findings of a unique exploratory survey on privacy literacy training procedures in university libraries. The poll analyses the justifications, subjects, contexts, approaches, and evaluations university librarians employ in providing privacy literacy teaching, as well as the obstacles they face. The study concludes with a case study that details the authors' own experiences with privacy literacy training and offers specific suggestions for removing the obstacles to giving privacy literacy instruction in academic libraries that were discovered by the survey's results.

Noh in the year 2020 conducted a study on the changes in librarians' perception before and after user privacy education and librarians' attitudes regarding patron privacy in libraries. The study traced how people's perceptions have changed as a result of receiving information on library patrons' privacy. By contrasting its findings with other researches, it was possible to determine how perceptions of privacy issues in libraries had changed over the previous five years. The findings revealed that librarians' interest in and awareness of library users' privacy in 2019 is significantly higher than it was in 2013, that after education, there was a significant increase in awareness of the risks associated with collecting user data and there was a greater openness to and willingness to recommend the education courses to their peers.

Pedley in the year 2020 published a book named a practical guide to privacy in libraries, to examine privacy concerns that occur in a library setting and offer suggestions for how librarians and information specialists might safeguard the privacy of their patrons. It provides readers with insights and actionable advice by using a variety of real-world examples of these problems evaluated privacy as a fundamental virtue of librarianship, which is challenging to articulate as a concept and to sustain in practise along with the importance of GDPR and contains a variety of tools that libraries can use to explain how they manage user personal data with their privacy policy statements, privacy audits, and data protection impact analyses.

Pekala in the year 2017 examined that in the technological shift in delivery of digital services, privacy became a prominent and complex issue for libraries. The study identified that the rise of the data economy caused online tracking and spying in which numerous third parties gather and exchange user data. It mainly happens during the discovery process, which makes harder for libraries to preserve patron privacy. The study concludes that libraries should balance the requirement to fulfil changing user needs and their privacy to access information they desire.

Campbell & Cowan 2016 specify that one of the eleven ideals in the American Library Association's "Core Values of Librarianship" which points to the protection of user privacy and confidentiality, most essential to the ethics and practise of librarianship. The study discussed the issues of privacy protection in libraries as they apply to patrons who utilise the information, programmes, and physical spaces to define, explore, and negotiate their sexual identities.

Caro & Markman in the year 2016 analysed that educating the public about cyber security issues and resources is essential. The study explained the necessity in conducting internal audits to ensure that the content partners and IT vendors take cyber security as seriously as the library and

its staff. The study analysed, reviewing the connections with current vendors on a regular basis is necessary. The study suggested providing a roadmap for whatever security features or policy statements the library can or should demand going forward and properly understand existing vendor agreements and how they rank, designed to be utilised by both technical and non-technical workers.

### **Objectives of the Study**

1. To analyze different types of library privacies provided by University Libraries
2. To determine the attitude of library professionals regarding digital privacy.
3. To examined the privacy policies and practices that libraries have implemented.
4. To assess the occasion where user privacy policies and practices are discussed.
5. To investigate the connection between privacy and technical growth.
6. To analyze the coping mechanisms undertaken by libraries to tackle data breach issues.
7. To find out the hurdles in implementing digital privacy.

### **Methodology**

A structured questionnaire was adopted for the study, which is best suited regarding the objectives formulated. The population consists of the library professionals in the four universities in Kerala- the University of Kerala (UoK), Mahatma Gandhi University (MGU), University of Calicut (UoC) and Kannur University (KU). A sample of 154 was taken from the total population of 252, representing the library professionals from the above mentioned four universities. A well-structured questionnaire was designed both in print and Google form, pretested and shared among the selected sample. Among 252 library professionals, 44 belongs to University of Calicut, 15 from Kannur University, 22 respondents from Mahatma Gandhi University and 73 samples were taken from University of Kerala. The data collected were subjected to analysis and inferences were drawn.

### **Data Analysis**

The primary purpose of the study is to understand the awareness, alertness and preparedness for putting the digital privacy rules into practice by four University Libraries in Kerala during a period of 1<sup>st</sup> September 2022 to 1<sup>st</sup> October 2022. Data obtained through Google form and questionnaire were directly converted to CSV file and imported into Microsoft Excel 2013 and analysed and interpreted the data using SPSS 22 version.

#### *1. Profile of the Library Professionals Taken For the Study*

For the study, data from library professionals in different designations of four prominent university libraries in Kerala namely, University of Kerala (UoK), Mahatma Gandhi University (MGU), University of Calicut (UoC) and Kannur University (KU) were taken.

#### *2. Types of Privacy Provided By Libraries*

Professor Bert J Koops formulated eight types of privacy which are Bodily Privacy, Spatial Privacy, Communicational Privacy, Proprietary Privacy, Decisional Privacy, Associational Privacy, Behavioural Privacy and later added Informational Privacy to it.

From the Table II, it is analysed that in University of Calicut, spatial privacy (61.54%) was the type of privacy provided to users and University of Kannur it is spatial privacy (95.24%). In University of Kerala, intellectual privacy (87.50%) is the most responded type of privacy and in Mahatma Gandhi University, spatial privacy (82.86%) and communicational privacy (82.86%) are the type of privacy availed to users.

TABLE I PROFILE OF THE LIBRARY PROFESSIONALS TAKEN FOR THE STUDY

	Characteristics	Number of Respondents	Percentage (%)
<b>Gender</b>	Female	87	56.49
	Male	67	43.51
<b>Age</b>	20-29	15	9.74
	30-39	11	7.14
	40-49	80	51.95
	50-59	48	31.17
<b>Education*</b>	M.L.I. Sc	154	100.00
	M Phil	11	7.14
	PhD	20	12.99
	PG Diploma	8	5.19
<b>Designation</b>	Assistant Librarian	5	3.25
	Assistant Librarian Gr I	16	10.39
	Assistant Librarian Gr II	47	30.52
	Assistant Librarian(SG)	7	4.55
	Assistant Librarian(SS)	2	1.30
	Deputy Librarian	2	1.30
	Junior Librarian	19	12.34
	Library Assistant	11	7.14
	Professional Assistant Gr I	9	5.84
	Professional Assistant Gr II	7	4.55
	Reference Assistant	18	11.69
	Reference Assistant(H.G)	3	1.95
	Technical Assistant	7	4.55
	University Librarian	1	0.65
<b>University</b>	Calicut University	26	16.88
	Kannur University	21	13.64
	Mahatma Gandhi University	35	22.73
	University of Kerala	72	46.75
	Total	154	100.00

\*Multiple responses

### 3. The Library Professionals and Digital Privacy

In the below Table III, the awareness of library professionals on digital privacy is shown. Librarians are aware that along with satisfying user's information needs, they must support their clients' right to privacy and freedom of inquiry since libraries are places where information can be accessed without restriction. Table III depicts opinion of library professionals on digital privacy in the context of libraries. The study shows that 84.51% library professionals of University of Kerala, 88.57% of Mahatma Gandhi University, 100% Kannur University and 65.38% of Calicut University agree with the statement digital privacy as the ability to send files, data,

communications and other information across the internet without leaking it to unauthorised parties. About 88.73% library professionals of University of Kerala, 68.57% of Mahatma Gandhi University, 95.25% Kannur University and 61.54% of Calicut University agree with the statement digital privacy as the safeguarding of personal data that user browse while accessing the IT services of the library.

TABLE II TYPES OF PRIVACY PROVIDED BY LIBRARIES

Type of Privacy	University of Calicut		University of Kannur		Mahatma Gandhi University		University of Kerala	
	n	%	n	%	n	%	n	%
Bodily privacy	13	50.00	2	9.52	5	14.29	60	83.33
Spatial privacy (Personal privacy)	16	61.54	20	95.24	29	82.86	55	76.39
Communicational privacy	13	50.00	20	95.24	29	82.86	61	84.72
Proprietary privacy	2	7.69	4	19.05	6	17.14	57	79.17
Intellectual privacy	3	11.54	18	85.71	7	20.00	63	87.50
Decisional privacy	7	26.92	1	4.76	14	40.00	56	77.78
Associational privacy	0	0.00	2	9.52	3	8.57	53	73.61
Behavioural privacy	4	15.38	2	9.52	5	14.29	54	75.00
Informational privacy	12	46.15	0	0.00	11	31.43	61	84.72

TABLE III THE LIBRARY PROFESSIONALS AND DIGITAL PRIVACY

S. No.	Parameters	Calicut University		Kannur University		Mahatma Gandhi University		University of Kerala	
		n	%	n	%	n	%	n	%
Digital privacy	Ability to send files, data, communications and other information across the internet without leaking it to unauthorised parties.	17	65.38	21	100.00	31	88.57	60	84.51
	The safeguarding of personal data that user browses while accessing the IT services of the library.	16	61.54	20	95.24	24	68.57	63	88.73

4. Privacy Policies and Practices in University Libraries

University libraries offer a variety of digital services, including e-mail, remote information services, special collection services, and reference services. Majority of the library professionals use both electronic and print form to store library resources. In order to maintain law and order libraries provides various security measures for the protection of users, staffs and library resources.

About 84.97% library professionals responded to reference desks as the most provided security measure provided to users, 80.39% responded to installation of CCTV camera monitoring library and 46.41% responded to self-serve displays in library. None responded to non-disclosure of user

reading data which is the most important security aspect in terms of security provided by library. Table IV shows the security measures provided to users in the university library.

TABLE IV THE PRIVACY POLICIES AND PRACTICES IN UNIVERSITY LIBRARIES

Security Measures	Number of Respondents	Percentage (%)
CCTV camera monitoring the library	123	80.39
Privacy Screens	53	34.64
Self-Serve Displays	71	46.41
Reference Desks	130	84.97
Sensitive Data Displays	30	19.61
Non-disclosure of user reading records	0	0.00
Safety from theft, physical harm inside library	64	41.83
Protection of online accounts owned by users for accessing digital services from the library	61	39.87

\*Multiple responses

### 5. User Privacy Policies and Practices

As more library services are shifting to the digital medium it is high need for libraries to formulate their own privacy policy and discuss the importance of ensuring privacy in the library. For this the respective authority and library professionals should take initiative to discuss about this in the formulation of privacy.

Table V shows the responses of library professionals on the occasion where importance of Library privacy is discussed.

TABLE V USER PRIVACY POLICIES AND PRACTICES

Occasions	Number of Respondents	Percentage (%)
Board level	42	27.27
Annual general meeting	27	17.53
Management level	89	57.79
Staff meetings	59	38.31
Consultation with technical advisors (like Software manufacturers)	54	35.06
Users or User group meetings	17	11.04
Don't know	22	14.29

\*Multiple responses

### 6. The Impact of Technical Growth and Privacy

The adoption of technology paved way for the acquisition of personal patron information and records of patron information-seeking behaviour that were not attainable in the pre-digital library time. Thus, not only technical growth should be given importance, but also strengthening of privacy and data security measures. Some among the range of threats resulted from technical growth that affect privacy of data are virus, malware attacks, theft and damage of data, improper data backups and unauthorised access. Table VI shows the range of threats that affect digital library resources.



TABLE VI THE IMPACT OF TECHNICAL GROWTH AND PRIVACY

Digital Library Threats	Calicut University		Kannur University		Mahatma Gandhi University		University of Kerala	
	n	%	n	%	n	%	N	%
Virus, Malware attacks	13	50.00	21	100.00	33	94.29	68	94.44
Theft and damage of data	6	23.08	4	19.05	22	62.86	57	79.17
Improper data backups	8	30.77	20	95.24	21	60.00	37	51.39
Unauthorised access	11	42.31	2	9.52	19	54.29	43	59.72

7. *Coping Mechanisms to Tackle Data Breach*

Coping mechanisms are the strategies adopted to tackle difficult situations. In the study coping mechanism implies strategies adopted by libraries when privacy, both physical and digital and library data are put into difficult situations like hacking, data breach etc.

From the study it is clear that 83.66% library professionals discuss with the management authority about the data breach issue, 26.14% responded that they discuss the matter with their friends and work colleagues, 22.88% responded they immediately report the issue to the police and a minority of 5.88% responded they ignore such issues. Table VII shows the coping mechanisms undertaken by university libraries to tackle data breach issues.

TABLE VII COPING MECHANISMS TO TACKLE PRIVACY BREACH

Coping Mechanisms	Number of Respondents	Percentage (%)
Discuss with the Management authority	128	83.66
Report to police	35	22.88
Discuss with friends and work colleagues	40	26.14
Ignore	9	5.88

\*Multiple responses

8. *Hurdles in Implementing Privacy*

Some of the main concerns that prevent libraries from providing better digital services are economic reasons, technological obsolescence, copyright issues, lack of expertise and administrative factors. Table VIII shows the library professionals responses regarding the physical challenges that prevent library from providing better digital services.

TABLE VIII HURDLES IN IMPLEMENTING PRIVACY

Challenges	Number of Respondents	Percentage (%)
Economic reasons	122	79.22
Technological obsolescence	53	34.42
Copyright issues	69	44.81
Lack of expertise	48	31.17
Administrative factors	70	45.45

\*Multiple responses

### Findings of the Study

1. Majority of the library professionals responded to communicational privacy (79.87%) as the privacy availed to users the most.
2. Majority of the library professionals has knowledge about digital privacy and data protection. About 84.31% of library professionals agree with the statement digital privacy as, the ability to send files, data, communications and other information across the internet without leaking it to unauthorized parties and 80.39% library professionals agree with the statement digital privacy as, the safeguarding of personal data that user browse while accessing the IT services of the library.
3. As per the study, it is visible that 84.97% library professionals responded to reference desks as the most provided security measure provided to users, 80.39% responded to installation of CCTV camera monitoring library and 46.41% responded to self-serve displays in library. None responded to non-disclosure of user reading data which is the most important security aspect in terms of security provided by library.
4. Majority of the library professionals are aware of privacy policy in their libraries and less number of library professionals are not aware. Library privacy is discussed mainly at management level, during staff meetings and during consultation with technical advisors or software manufacturers. A meagre number of library professionals are not aware of any kind of library privacy discussion.
5. Most of the library professionals are aware of issues related to virus, malware attacks, improper data backups, unauthorized access, theft and damage of data that can affect information stored by library. All the library professionals from Kannur University, 94.44% of Kerala University, 94.29% of Mahatma Gandhi University and 50% of Calicut University responded to threats from virus, malware attacks followed by, 79.17% from Kerala University, 62.86% from Mahatma Gandhi University, 23.08% from Calicut University and 19.05% from Kannur University responded to theft and damage of data. About 95.24% from Kannur University, 60% from Mahatma Gandhi University, 51.39% from Kerala University and 30.77% from Calicut University responded to issues with improper data backups. Finally, 59.72% from Kerala University, 54.29% from Mahatma Gandhi University, 42.31% from Calicut University and 9.52% from Kannur University responded to issues of unauthorised access.
6. The most immediate response of library professionals is discussing the matter with the management authority. Depending upon the gravity of the situation, discuss with work colleagues, the management authority and police is done as soon as possible.
7. Majority of the library professionals responded to *economic reasons* (79.22%) and 45.45% responded to *administrative factors*. Least responded challenge is *lack of expertise* by 31.17% responded on *the physical challenges that prevent library from providing better digital services*.

### Conclusion

Achieving privacy protection of users can't be simply achieved in an overnight, instead it is a gradual process of identifying the strength and weakness of existing policies, conducting audits and impact assessments of library systems and procedures, security protocols, legal frameworks, information management practices and analyzing problems occurred and strategies adopted by

other libraries to mitigate the situation. Libraries should take adequate initiatives to carry out privacy audits, frequent data protection impact assessments and suggesting new services to be introduced. Privacy policies should be established and frequently revised to improve things for the future which include, strengthening protection of user privacy, network security checks, understanding complaints of users on disclosure of data, security, usage of their data etc. The protection of user privacy is a continuous process and there is no perfect solution to ensure this forever because, the nature and severity of potential threats change overtime, policies adopted by each and all libraries change overtime and the technologies and vendors they depend changes overtime. An effective communication between authorities and library professionals will provide opportunities to address these issues and libraries will be known not only as an institution which provides reliable information to users, but also as a responsible institution which can handle and protect personal information of users and their privacy.

## References

- [1] *Advocacy, legislation & issues.* (2019). Advocacy, Legislation & Issues. <https://www.ala.org/advocacy/intfreedom/privacyconfidentiality>.
- [2] *ALA privacy policy.* (2022, August 26). American Library Association. <https://www.ala.org/privacypolicy>.
- [3] Campell, G. D., & Cowan, S. (2016, season-04). The Paradox of Privacy: Revisiting a Core Library Value in an Age of Big Data and Linked Data. *Library Trends*, 64(3), 492–511.
- [4] Caro, A., & Markman, C. (2016, April 25). Measuring Library Vendor Cyber Security: Seven Easy Questions Every Librarian Can Ask. *Code4lib*, 32.
- [5] Eroğlu, A., & Cakmak, T. (2020, November). Personal data perceptions and privacy in Turkish academic libraries: An evaluation for administrations. *The Journal of Academic Librarianship*, 46(6), 102251. <https://doi.org/1016/j.aca;ib.2020.1102251>.
- [6] Hartman-Caverly, S., & Chisholm, A. (2020, December). "Privacy Literacy Instruction Practices in Academic Libraries: Past, [Present and Possibilities." *IFLA Journal*, 46(04).
- [7] Koops, B.-J., Newell, B. C., Timan, T., Skoryanek, L., Chokrevski, T. and Galic, M. (2017) A Typology of Privacy, *University of Pennsylvania Journal of International Law*, 38(2), 483-575.
- [8] Noh, Y. (2020, July). A study on the changes in librarians' perception before and after user privacy education. *Library & Information Science Research*, 42(3), 101032. <https://doi.org/10.1016/j.lisr.2020.101032>.
- [9] Pedley, P. (2020, March 19). *A Practical Guide to Privacy in Libraries*. Facet Publishing.
- [10] Pekala, S. (2017, June 28). Privacy and User Experience in 21<sup>st</sup> Century Library Discovery. *Information Technology and Libraries*, 36(2), 48-58. <https://doi.org/10.6017/ital.v36i2.9817>.
- [11] Tavani, H. T., & Himma, K. E. (2008). Informational Privacy: Concepts, Theories and Controversies. *The Handbook of Information and Computer Ethics*, 131-164. <https://doi.org/10.1002/9780470281819.ch6>.

# Collection Management of Electronic Information Resources for Academic Libraries

H. G. Srikanth<sup>1</sup> and Dr. Malatesh N. Akki<sup>2</sup>

<sup>1</sup>Research Scholar, <sup>2</sup>Research Supervisor,  
<sup>1&2</sup>CMR University, Bangalore, Karnataka, India  
E-mail: srikanth.19cphd@cmr.edu.in

## Abstract

*In today's age of information technology, the majority of information is accessible in a digital format. Various organizations are building and developing digital libraries. Compared with traditional libraries, digital libraries need a distinct set of skills and abilities to manage digital their holdings. The collection development approach has witnessed an actual shift in the realm of digital content, mainly due to the numerous and easily available digital materials found on the internet. This study aims to highlight the importance of collection development policy, the creation of web-based collections, and the difficulties faced in developing collections in the digital age.*

**Keywords:** Collection Development, Collection Development Policy, Digital Age, Digital Library, Electronic Resource Management, Electronic resources.

## Introduction

Academic libraries are using advanced technologies to improve their collections, which include both physical and digital resources, utilizing new web technologies that offer users an enhanced, dynamic, and inviting environment that is interactive and visually appealing, complete with multimedia collections and services. Several academic libraries are actively expanding their collection of full text documents in digital form and persevere in using multiple online databases. Electronic resources are becoming more accessible, which has helped increase their market share. Libraries also included E-resource modules to their management systems. However, every management must carefully examine factors like selecting and acquiring electronic resources to meet user information demands. Considering changing user demands, libraries are shifting towards emerging technologies for their overall growth.

Electronic Resource Management enables libraries to oversee their e-resources authorization and procurement details using a unified system, speeding workflows and eliminating the need for maintaining separate databases.

## Review of Literature

Ngurtinkhuma (2015) discusses collection development components, challenges and their importance for the e-resources implementation. To maintain the library's digital credibility, librarians and other authorities must accept the challenge.

Panage & Bonde (2016) in their article it provides an in-depth examination of the significance of digital resources, digital libraries, and collection development. The article focuses on the process of creating a digital collection, specifically in relation to born digital and in-house digital resources.

Kaur *et al.*, (2017) they have highlighted the importance of collection development policy, the development of internet-based collections, and the challenges faced in developing collections in the digital age. This article also examines the trends and requirements for collection development in the digital age.

Bala (2021) in his article he has covered e-collection policy, selection criteria, bibliographic concerns, digital preservation, perpetual access, and context. This paper concludes by urging users and staff to adapt to this e-environment by enhancing information, literally user communication, and highlighting e-collection management at all levels.

Ram *et al.*, (2022) researchers highlighted digital collection creation challenges and management. The study concluded that library staff should take extra effort to provide an even-handed collection that raises standards.

### **Electronic Resource**

Electronic resources refer to digital information that may be accessed via devices such as computers, smart phones, tablets, and e-readers. The items included are e-books, e-journals, online databases, and multimedia materials. Their popularity comes from their accessibility, cost-effectiveness, efficiency, and eco-friendliness. Electronic resources have completely altered the way information is accessed and distributed in the fields of education, research, healthcare, and business. Electronic resources will remain essential in the digital era as technology advances.

The following are the types of electronic resources which are most commonly used in libraries: E-books, E-conference proceedings, E-databases, E-journal E-lectures, E-magazines, E-news, etc..

#### *1. Impact of E-Resources and Services on Higher Education and Research*

The integration of electronic resources and services has brought about a revolutionary transformation in higher education and research. Access to a vast and diverse repository of digital information has dismantled geographical barriers, providing scholars and students with unprecedented opportunities to explore a global landscape of knowledge. This accessibility has not only expedited the research process but has also enhanced research productivity by enabling swift and comprehensive information retrieval. Collaborative research opportunities have flourished as scholars globally can now engage in joint projects, share resources, and contribute to interdisciplinary endeavors through digital platforms. Moreover, the customization and personalization afforded by e-resources have empowered learners and researchers to tailor their educational experiences, focusing on specific topics and formats that align with their unique preferences and goals. While these advancements offer immense benefits, challenges such as the digital divide, accessibility issues, and the need for enhanced digital literacy must be addressed. As higher education adapts to evolving pedagogical approaches and embraces the possibilities of digital technologies, the impact of e-resources continues to shape a dynamic and innovative landscape for academia.

#### *2. Collection Development in Digital Age*

Collection development in academic libraries has significantly transformed in the digital age, with the increasing inclusion of toll-based electronic resources and the need to evaluate and integrate open access electronic scholarly content. Librarians who vet materials and organize collections create the foundation for academic services and outreach efforts. The prevailing attitude is that all information will eventually be free on the web, but the library must retain its relevance as collections move to digital formats. Collection development librarians can identify new digitization initiatives, seek grant funding, and leverage collaborations to maximize the availability and dissemination of open web scholarly research materials. They add value by integrating valuable open web contents alongside traditional library materials, organizing available quality scholarly materials through web lists, research guides, Lib Guides, course management systems, and integrated library systems.

## **Key Components for Digital Library Development**

For digital libraries to succeed, several challenges must be addressed. Digital library management identifies and implements problems at different stages of development and usage. The following categories describe the main digital library components. The elements are briefly discussed.

### *1. Collection Management of E-Resources*

Collection management combines print and digital resources. Collection management and development are often similar. Collection development involves choosing resources based on institution goals, user needs, and budget. Collection development and management involve selecting, acquiring, preserving, weeding, cancelling, and giving access to serials/journals.

The e-collection development process is a systematic approach to building library collections using electronic devices like computers. This process is based on meaningful information rather than subjective choice and involves selecting current and retrospective information, materials, and evaluating existing e-collection materials. The goal is to satisfy the information requirements of users. As a result, libraries are re-orienting their collections and policies to incorporate e-resources, transforming not only the process of collection development but also the role of librarians.

### *2. Collection Development Policy*

Libraries should adopt an explicit collection development policy to ensure they select the right electronic resources for their mission. This policy prevents haphazard unfocused groupings and helps avoid resistance to change. Most libraries are still in their infancy, so they should proceed in a structured way. A fully integrated collections policy will be appropriate when print and electronic resources reach a balance. The policy should be flexible, sensitive to local needs, priorities, and culture, and part of an institutional Information Strategy.

The collections policy should balance user wants and needs for electronic information resources. Academics often prioritize improved journal collection and better access to external electronic databases. An explicit collections policy prevents haphazard unfocused groupings of resources and helps avoid resistance to change within the institution. Most libraries are still in their infancy when it comes to providing access to electronic information, so selection decisions should be made within an explicit collection development policy. A fully integrated collections policy will be appropriate in time, but it is important to present major moves into electronic resources as part of an agreed library strategy with institutional support. Policy statements should be flexible and sensitively interpreted within local needs, priorities, and culture.

### *3. Selection Criteria*

Selecting electronic resources requires careful consideration of factors such as authority, accuracy, currency, and relevance. Collaborative decision-making involving librarians, faculty, and students ensure that the collection aligns with academic goals and supports research endeavors.

### *4. Licensing and Access*

Negotiating licenses for electronic resources involves understanding the terms and conditions set by vendors. Access management, including authentication and authorization protocols, is essential to ensure seamless access for authorized users while safeguarding against unauthorized use.

### *5. Budgetary Considerations*

Managing budgets for electronic resources requires a balance between acquiring new resources, renewing existing subscriptions, and exploring cost-effective alternatives. Libraries must stay vigilant in assessing the return on investment and explore consortia purchasing for cost savings.

### *6. Preservation and Archiving*

Preserving electronic resources involves planning for potential disruptions, ensuring data integrity, and considering digital archiving solutions. Collaboration with other institutions and leveraging initiatives like LOCKSS (Lots of Copies Keep Stuff Safe) enhances the longevity of digital collections.

### *7. Usage Assessment and Analytics*

Tracking the usage of electronic resources is vital for informed decision-making. Utilizing analytics tools helps libraries understand user behavior, assess the popularity of resources, and identify areas for improvement or reallocation of funds.

### *8. Training and Support*

Providing training and support for users is essential to maximize the benefits of electronic resources. Librarians should offer workshops, tutorials, and guides to help users navigate and utilize these resources effectively.

## **Challenges of Using EIR by Academic Libraries**

A lot of individuals prefer electronic resources, yet there are several challenges to their widespread adoption. E-resources have provided huge advantages above paper resources in library organization. However, smart libraries encounter multiple challenges in order to continue providing important services to their users. Igun (2005) felt that libraries and information centres' challenges in establishing electronic resources include managing current e-instruments, metadata data for ordering e-resources, e-journal expertise, and URL maintenance. Inadequate PCs, insecure internet connection, and lack of mobility capabilities limited students' utilization of electronic resources for information and care.

### *1. Issues and Challenges among the Librarians*

Harish Chandra (2012)'s challenges as described below highlight e-resource issues related to management. Even if it's difficult, librarians have to include new technology-based services to maintain the library's appearance.

- a) Identification of suitable sources for electronic resources.
- b) Building enough infrastructures to provide e-resource services.
- c) Training skilled personnel to manage the electronic resources.
- d) Examining methods to implement a content management service in place of a document management service.
- e) Facilitating user education via technological commutes and training to maximize library resources.
- f) Delivering high-quality library services in the field of information and communication technology.
- g) The approach to convincing the authorities to allow electronic collections in the library.
- h) Encouraging library professionals to collaborate in the new endeavor.
- i) Providing professionals with knowledge and skills in the use of technology.

Considering the above, future librarianship will be much more difficult as multiple factors, mentioned below, impact the profession, causing librarians to adapt to and accept the challenges of 21st century technology:

- a) The emergence of new databases as well as digital libraries.
- b) The explosion of information.

- c) The ever-changing information demands of users.
- d) The building of collections depends on requirements.
- e) Research covering several disciplines.
- f) Reducing the budget of the library.
- g) Highly qualified personnel.
- h) Quality Control and Assurance of Services.
- i) Availability of a large number of electronic resources in a variety of forms.
- j) Building of digital repositories.
- k) Promoting the acquisition of knowledge retrieval skills among the users.
- l) Providing internet access to the library.

### 2. *The Advantages of Digital Collections*

- a) Global Accessibility.
- b) 24/7 Availability.
- c) Efficient Search ability.
- d) Cost-Effective Storage.
- e) Enhanced Interactivity.
- f) Customization.
- g) Collaborative Opportunities.
- h) On-Time Updates.
- i) Integration with Emerging Technologies.
- j) Accessibility for Diverse Audiences.

### 3. *The Disadvantages of Digital Collection*

- a) Access Inequality
- b) Preservation and archiving for a long term
- c) Security and Privacy Risks.
- d) Dependency on Technology.
- e) Costs and Resource Intensity.
- f) Quality and Authenticity Concerns.
- g) Accessibility Issues.
- h) Licensing and Copyright Complexity.
- i) Lack of compatibility among different publishers
- j) Data loss due to technological failures or cyber threats.

### **References**

- [1] Bala Sankar, "An Analysis of E-Collection Management in an Academic Library: A Case Study" (2021). *Library Philosophy and Practice* (e-journal). 6614.
- [2] Barbara Susana Sanchez. Collection development in an digital environment: An imperative for information organizations in the twenty-first century. *Collection building*, 2006, 25(4), p.139-144.
- [3] Harish Chandra (2012). E-Resources Management with Specific Reference to E-Reference Sources: Initiatives and Issues, Available at [eprints.rclis.org/6695/1/resources.pdf](http://eprints.rclis.org/6695/1/resources.pdf)
- [4] Jalal, S. K., & Vishwamohan, V. (2009). Collection development in digital environment: A case study. *Indian journal of library and information science*, 3(3), 151-160.
- [5] Kaur, G., & Anilkumar, P. D. Collection development strategies for e-resources in an academic libraries. Unpublished manuscript, Department of Library and Information Science, Gulbarga University, Gulbarga, Karnataka, India. (Retrieved from [http://www.academia.edu/14244980/collection\\_development\\_strategies\\_for\\_e-resources\\_in\\_an\\_academic\\_libraries](http://www.academia.edu/14244980/collection_development_strategies_for_e-resources_in_an_academic_libraries))



- [6] Kaur, R., & Gaur, R. (2017). Collection development in academic libraries with special reference to digital era. *International Journal of Digital Library Services*, 7(2), 107-114.
- [7] Kavitha, R. (2009). Collection development in digital libraries: trends and problems. *Indian Journal of Science and Technology*, 68-73.
- [8] Mishra, R. N., & Ngurtinkhuma, R. K. (2015). Collection development and management of e-resources: issues and challenges for librarians in digital environment. *VSRD International Journal of Technical and Non-Technical Research*, 6, 53-61.
- [9] Panage, B. M., & Bonde, H. S. (2016). Collection development of digital resources: some issues. *International journal of library and informational science (IJLIS)*. 5 (2), 102, 107.
- [10] Ram, M., Singh, S., & Kumar, R. (2022). Collection development in digital era & its difficulty and administration. *International Journal of Information Dissemination and Technology*, 12(1), 19-22.
- [11] Ramaiah, C. K. (2013). *Electronic Resources Management in Libraries (Vol. 1)*. Allied Publishers.
- [12] Rao, A. P. (2007). *E-resource Management: Issues and Challenges*. LS Ramaiah, E-Libraries Problem and Prospective, 78-88.
- [13] Rath, M. S., & Rath, P. (2014). Collection development in libraries: challenges and solutions for library professionals. *Pearl: A Journal of Library and Information Science*, 8(1), 53-64.
- [14] Reddy, K. H., & Chandraiah, I. (2017). Collection Development in University Libraries: A Case Study. *International Journal of Digital Library Services*, 7(3), 114-126.
- [15] Reddy, K. H., & Chandraiah, I. (2017). Collection Development in University Libraries: A Case Study. *International Journal of Digital Library Services*, 7(3), 114-126.
- [16] Varalakshmi, R. S. R. (2004). Collection management in digital environment: policy statement for university libraries in India. *Journal of Information and Knowledge (Formerly SRELS Journal of Information Management)*, 79-90.
- [17] Veeranjanyulu, K., & Kumar, N. R. (2018). *Management of E-resources in Academic Libraries: Issues and Challenges*.

# Connected Campuses: The Role of Networking in Private University Education

Sanjiv K. Sain<sup>1</sup> and Dr. Rajesh Kumar Singh<sup>2</sup>

<sup>1</sup>Research Scholar & Librarian, DIT University, Dehradun, Uttarakhand, India

<sup>2</sup>Professor, Department of Library & Information Science

<sup>1&2</sup>Himalayiya University, Jeevanwala, Doiwala, Uttarakhand, India

E-mail: sanjivsain74@gmail.com

## Abstract

*The paper explores the transformative impact of networking on private university education, focusing on connected campuses. It highlights the importance of improved communication, enhanced learning resources, and administrative efficiency resulting from networking initiatives. The study examines technological infrastructure, including Wi-Fi, learning management systems, and cyber security measures, and its impact on teaching, learning, and student experience. It also examines challenges such as inclusivity, privacy concerns, and faculty resistance to technological change. The paper presents case studies of successful implementations in specific private universities and discusses emerging trends in networking, such as artificial intelligence and virtual reality. The paper calls for universities to adapt and invest in connected campus initiatives to remain at the forefront of academic excellence in the digital age.*

**Keywords:** Networking, cyber security, networking, learning management systems, advantages, blended learning.

## Introduction

- 1. Background of Private Universities:* Private universities, a distinct sector within higher education, have a history shaped by diverse motivations, funding models, and educational philosophies. In contrast to public universities funded by government sources, private universities rely on private funding, tuition fees, and endowments. The roots of private higher education can be traced back to religious institutions and early colonial colleges. Over time, private universities have evolved to encompass a wide range of academic disciplines, often emphasizing specialized programs, smaller class sizes, and a focus on innovation. They play a crucial role in offering alternative educational approaches and contributing to the overall diversity of the higher education landscape.
- 2. Significance of Networking in Higher Education:* Networking is a crucial aspect of higher education, offering numerous benefits such as collaboration, interdisciplinary research, professional development, career opportunities, information sharing, global perspectives, institutional advancement, a supportive community, lifelong learning, entrepreneurship, and community engagement. It allows students to connect with professionals, alumni, and experts, gain insights into industry trends, and build relationships that may lead to internships or employment. Networking also fosters global perspectives, institutional advancement, and entrepreneurship, leading to new technologies and research initiatives.
- 3. Thesis statement: "Connected Campuses: Exploring the Impact of Networking on Private University Education":* "Connected Campuses: Exploring the Impact of Networking on Private University Education" investigates the multifaceted influence of networking within private higher education institutions, examining its role in fostering interdisciplinary collaboration, enhancing professional development, facilitating global perspectives, and

contributing to institutional advancement, ultimately shaping a holistic and dynamic educational experience for students and faculty alike.

## Historical Perspective

1. *Evolution of Private Universities:* Private universities have evolved over time due to societal, economic, and educational changes. Key factors include historical context, diversification of programs, globalization, technological advancements, entrepreneurial focus, financial models, governance, research and innovation, student-centric approaches, market demand adaptation, and inclusion and diversity.
2. *Technological Advancements in Higher Education:* Technological advancements in higher education have improved teaching, learning, administration, and student engagement. Key technologies include online platforms, blended learning, virtual and augmented reality, AI, cloud computing, gamification, data analytics, blockchain, collaborative tools, and smart classrooms, enhancing learning experiences.
3. *Emergence of Networking in Campus Settings:* Campus networking has revolutionized communication, collaboration, and information access in educational institutions through technological advancements, robust infrastructure, and learning management systems. The integration of IoT, cloud computing, and emergency notification systems further enhances its benefits, shaping the future of education.

## The Importance of Networking in Private University Education

### A. Improved Communication

The integration of technology, strategic planning, and transparent communication in higher education has significantly improved communication. Key factors include digital platforms, learning management systems, social media engagement, mobile apps, collaborative tools, feedback mechanisms, accessibility measures, professional development opportunities, and data analytics.

1. *Faculty-Student Interaction:* Faculty-student interaction is crucial for student engagement, academic success, and satisfaction. Strategies include accessible office hours, active class participation, technology-mediated communication, mentorship programs, small group discussions, extracurricular involvement, encouraging questions, academic advising, support services, inclusivity, professional development opportunities, social media use, and flexibility.
2. *Student Collaboration and Engagement:* A successful learning environment involves student collaboration and engagement through active learning techniques, technology integration, group projects, peer review, flipped classroom models, collaborative spaces, interdisciplinary projects, guest speakers, gamification elements, service learning, flexible grouping, reflection, self-assessment, and inclusive practices. These techniques foster teamwork, interpersonal skills development, critical engagement, open discussions, and consider diverse learning styles and abilities.

### B. Enhanced Learning Resources

#### 1. Online Libraries and Databases

Online libraries and databases are vital in modern education and research, providing global access to academic resources, diverse content, search tools, remote learning support, open access

initiatives, collaboration, and continuous updates. They break geographical barriers, offer 24/7 access, and integrate with Learning Management Systems.

## *2. Access to Research Materials and Academic Resources*

Access to research materials and academic resources is crucial for students, researchers, and scholars. Key factors include library resources, online databases, open access repositories, interlibrary loan services, e-book collections, Google Scholar, learning management systems, research networking platforms, citation management tools, conference proceedings, professional associations, and podcasts.

## *C. Administrative Efficiency*

### *1. Student Record Management*

Student record management is the systematic organization, storage, and maintenance of student information throughout their academic journey. It involves a comprehensive Student Information System, data security, electronic records management, attendance management, financial records, health and wellness information, graduation and degree audits, document management, integration with Learning Management Systems, reporting and analytics, and continuous system updates.

### *2. Registration and Course Management Systems*

Educational institutions use registration and course management systems for efficient enrollment, scheduling, and academic management. These systems provide an intuitive interface, real-time course availability information, pre-requisite checks, waitlist management, payment integration, and guest registration. Regular updates, user training, and feedback mechanisms ensure continuous improvement.

## **Technological Infrastructure in Connected Campuses**

### *1. Campus-Wide Wi-Fi and Internet Connectivity*

Modern educational institutions require reliable Wi-Fi and internet connectivity for seamless access to digital resources, online learning, and enhanced communication. Key considerations include network planning, scalability, frequency planning, outdoor coverage, high-quality equipment, redundancy, load balancing, QoS, security, guest network, roaming support, band steering, capacity management, maintenance, and regular updates and user support.

### *2. Integration of Learning Management Systems (LMS)*

Learning Management Systems (LMS) are crucial in modern educational institutions for online course delivery, resource management, and improved communication. Integration involves considering institution needs, scalability, compatibility, user authentication, data integration, content management, mobile accessibility, training, support, customization, security, compliance, feedback, and external tools. Implementing single sign-on, role-based access control, data analytics, and mobile apps is essential.

### *3. Cyber Security Measures and Challenges*

Cyber security is crucial for protecting information systems, data, and digital assets, especially in educational institutions. These institutions face unique challenges due to diverse users, reliance on digital technologies, and sensitive information. Implementing measures like user education, endpoint protection, data encryption, network security, incident response plans, patch management, secure email gateways, software development, cloud security, and regular audits contributes to resilience against cyber threats.

## **Impact on Teaching and Learning**

### *1. Blended Learning and Online Courses*

Blended learning and online courses are educational methods that combine traditional face-to-face instruction with online components, offering flexibility and accessibility. Blended learning combines lectures with online activities, allowing students to review materials at their own pace. Online courses are delivered entirely or predominantly over the internet, catering to learners with geographical distances or self-paced learning preferences.

### *2. Virtual Classrooms and Collaborative Tools*

Virtual classrooms and collaborative tools are essential in modern education for interactive learning experiences. Virtual classrooms like Zoom, Microsoft Teams, Google Meet, Cisco Webex, and Adobe Connect provide global access and recording sessions. Collaborative tools enhance communication, resource sharing, and engagement, facilitating real-time collaboration, assignment discussions, feedback, project-based learning, and group assessments.

### *3. Faculty Development and Training for Technology Integration*

Technology integration in education necessitates faculty development and training, involving needs assessment, skill-based training, professional development opportunities, and collaborative learning communities. Strategies include workshops, online courses, peer mentoring, technology showcases, and simulation environments. Regular evaluation and feedback are crucial for refining training strategies. Investing in these initiatives empowers educators to effectively use technology and prepare students for the digital age.

## **Student Experience in Connected Campuses**

### *1. Social Networking and Academic Communities*

Social networking and academic communities are crucial for collaboration, knowledge sharing, and professional development among academics, researchers, and students. They facilitate global reach, interdisciplinary collaboration, community support, and real-time updates. Challenges include privacy, security, digital literacy, time management, information quality, and inclusivity. Effective use fosters innovation, knowledge dissemination, and professional growth.

### *2. Access to Extracurricular Activities and Campus Events*

Extracurricular activities and campus events are vital for students' holistic development, social integration, wellness, and community building. They develop skills like leadership, teamwork, communication, and time management, promote diversity, enhance career development, and provide cultural enrichment. Educational institutions should offer inclusive programming, diverse communication channels, and partnerships for student organizations and wellness.

### *3. Student Support Services through Online Platforms*

Online student support services enhance academic experience and well-being by providing virtual tutoring, writing centers, e-learning resources, academic advising, digital libraries, career counseling, online job boards, networking events, mental health workshops, and support communities. They also offer administrative and student life services, technology support, and remote access. Effective implementation requires accessibility, user-friendly interfaces, privacy, promotion, feedback, collaboration, and staff training.

## **Challenges and Considerations**

### *1. Digital Divide and Inclusivity*

The digital divide is a gap in access to modern ICT, impacting education, employment, healthcare, and civic participation. Strategies to address it include infrastructure development, subsidized

internet programs, community technology centers, mobile connectivity initiatives, digital literacy training, public awareness campaigns, government policies, collaboration with NGOs, tailored educational programs, and continuous monitoring and evaluation.

## *2. Privacy Concerns and Data Security*

In the digital age, privacy and data security are crucial due to the increasing use of technology for personal and sensitive information. Key concerns include data collection, surveillance, online tracking, biometric data, location tracking, and data breaches. Measures include encryption, access controls, audits, multi-factor authentication, data minimization, and vendor security assessments. Regulatory compliance is essential for protecting individuals' rights and maintaining trust.

## *3. Resistance to Technological Changes among Faculty*

Faculty resistance to technological changes in educational institutions is often due to factors like lack of familiarity, fear of job insecurity, time constraints, perceived relevance, and student engagement concerns. Strategies to overcome this resistance include clear communication, faculty involvement, professional development opportunities, showcasing success stories, creating a supportive community, acknowledging innovation, pilot programs, technical support, collaboration, continuous evaluation, policy concerns, comprehensive training programs, and investment in infrastructure.

## **Case Studies**

### *1. Highlight Specific Private Universities Embracing Connected Campuses*

Private universities like Stanford, Harvard, MIT, Duke, New York, Northwestern, University of Southern California, Vanderbilt, and the University of Chicago are utilizing advanced technology to enhance their educational experiences. Stanford has implemented learning management systems, interactive online courses, and collaborative platforms, while Harvard has invested in digital infrastructure for connected learning. MIT is known for its innovative use of technology, such as Open Course Ware.

### *2. Discuss Success Stories and Lessons Learned*

Success stories in higher education emphasize the importance of technology integration in enhancing the educational experience. ASU, UCF, Carnegie Mellon University, Georgia State University, and Stanford University have all implemented adaptive learning technologies, online learning, and blended learning and flipped classrooms. These institutions have achieved positive outcomes, increased student engagement, and narrowed achievement gaps. Lessons learned include a student-centric approach, faculty training, data-informed decision-making, flexibility, collaboration, inclusivity, continuous evaluation, and strong institutional support. These stories underscore the need for thoughtful planning and commitment to technology integration in higher education.

## **Future Trends and Innovations**

### *1. Emerging Technologies in Higher Education*

Emerging technologies in higher education include AI, Machine Learning, XR, Blockchain, 5G, IoT, Robotic Process Automation, Biometric Authentication, Voice Assistants, Natural Language Processing, Edge Computing, Quantum Computing, Cybersecurity Solutions, and Educational Data Mining and Learning Analytics. These technologies enhance learning experiences, automate administrative tasks, and support data-driven decision-making. XR provides immersive experiences, Blockchain ensures academic record integrity, 5G improves connectivity, IoT enhances campus efficiency, and RPA automates administrative tasks. Edge computing reduces latency, quantum computing advances research, and cybersecurity solutions protect sensitive data.

## 2. *The Role of Artificial Intelligence and Virtual Reality*

Artificial Intelligence (AI) and Virtual Reality (VR) are revolutionizing higher education by improving student engagement, enhancing predictive analytics, and automating grading processes. AI-powered adaptive learning systems analyze student progress, while predictive analytics help at-risk students retain their studies. AI-driven chatbots provide instant responses to student inquiries, while grading automation saves faculty time. Natural Language Processing (NLP) enhances accessibility and language learning. AI assists researchers in analyzing vast datasets, while AI tutoring systems support students. VR creates immersive learning environments, but institutions must consider infrastructure readiness, faculty training, and ethical considerations to maximize their positive impact.

## 3. *Anticipated Developments in Networking for Private Universities*

Private universities are set to experience significant networking advancements due to technological advancements, educational trends, and evolving needs. Key trends include 5G connectivity, edge computing, cloud-based networking, IoT integration, AI-driven management, blockchain, remote learning infrastructure, open educational resources platforms, and privacy-preserving technologies. These advancements aim to enhance connectivity, performance, security, and trust in educational platforms.

## **Conclusion**

Private universities are increasingly utilizing advanced networking technologies like AI, VR, 5G, cloud computing, and IoT to improve communication, collaboration, and academic management. These technologies enhance faculty-student interaction, student engagement, and access to online resources. Campus-wide Wi-Fi and internet connectivity are prioritized, and Learning Management Systems are integrated into the infrastructure. Cyber security measures are crucial to protect sensitive data. Faculty development programs focus on technology integration, ensuring educators are well-equipped to use networking tools.

Networking technologies are expected to significantly impact private university education by enabling flexible learning models, enhancing accessibility, promoting personalized learning, and facilitating immersive experiences. They will also improve campus management, support lifelong learning, and ensure data security. By strategically leveraging these technologies, institutions can provide innovative, accessible, and quality education, reducing the digital divide and ensuring broader internet access. Universities should invest in connected campus initiatives to improve student learning experiences, administrative efficiency, and prepare graduates for a rapidly changing world.

## **References**

- [1] Biancani, S., & McFarland, D. A. (2013). Social networks research in higher education. In M.B. Paulsen (Ed.). Higher
- [2] Carolan, B. V. (2013). Social network analysis and education: Theory, methods & applications. Thousand Oaks, CA: SAGE. <https://doi.org/10.4135/9781452270104>
- [3] Dawson, S. (2008). A study of the relationship between student social networks and sense of community. *Educational Technology & Society*, 11, 224–238.
- [4] Diramio, D., Theroux, R., & Guarino, A. J. (2009). Faculty hiring at top-ranked higher education administration programs: An examination using social network analysis. *Innovative Higher Education*, 34, 149–159. <https://doi.org/10.1007/s10755-009-9104-5>

- [5] Duncan, G. J., Boisjoly, J., Kremer, M., Levy, D. M., & Eccles, J. (2005). Peer effects in drug use and sex among college students. *Journal of Abnormal Child Psychology*, 33, 375–385. <https://doi.org/10.1007/s10802-005-3576-2>
- [6] Education: Handbook of Theory and Research, 28, 151–215. [https://doi.org/10.1007/978-94-007-5836-0\\_4](https://doi.org/10.1007/978-94-007-5836-0_4)
- [7] Festinger, L., Schachter, S., & Back, K. (1950). *Social pressures in informal groups: A study of human factors in housing*. New York, NY: Harper.
- [8] Grunspan, D. Z., Wiggins, B. L., & Goodreau, S. M. (2014). Understanding classrooms through social network analysis: A primer for social network analysis in education research. *CBE—Life Sciences Education*, 13, 167–178. <https://doi.org/10.1187/cbe.13-08-0162>
- [9] Ugander, J., Karrer, B., Backstrom, L., & Marlow, C. (2011). The anatomy of the Facebook social graph. Retrieved from <http://arxiv.org/abs/1111.4503>
- [10] Watanabe, M., & Falci, C. (2016). Workplace faculty friendships and work-family culture. *Innovative Higher Education*, 42, 113–125. <https://doi.org/10.1007/s10755-016-9373-8>
- [11] Zwolak, J. P., Dou, R., Williams, E. A., & Brewster, E. (2017). Students' network integration as a predictor of persistence in introductory physics courses. *Physical Review Physics Education Research*, 13. <https://doi.org/10.1103/physrevphyseducre.13.010113>.



# Information Literacy and User Education in Academic Libraries

**Dr. S. Rajunaik**

Librarian (Selection Grade), Govt. First Grade College, Holehonnur, Karnataka, India

E-mail: rajunaik\_sb@yahoo.com

## **Abstract**

*In this Information Literacy and User education in academic library topic we are mainly giving the information about different kinds of users and non-users and using materials and how to use it. What is the nature of information and different kinds of information? Characteristics of the user and education and how to educate the user. Different kinds of user education specification if user education nature of user education and information displayed containing information about opening hours. Library information rules, Library timings, staff maintained. Lecture methods may be formal / informal, workshop about the CD-ROM, online services practice workshop.*

**Keywords:** Information Literacy, User education, Lecture methods.

## **Introduction**

In information system user is an important component. But our librarians and information managers neglected this aspect for a long time. Access to relevant information is highly essential particularly in industrial, research and development sectors. Right information to the right user can gave way to new directions to research and development. It is imperative that to achieve this objective we should understand the library user, how they interact with the system, Academic libraries are at a turning point.

Historically, college and university libraries were the natural destination for students, faculty, staff, and researchers seeking information. These users came to the library by default. Academic libraries served as the repository for published information as well as the intermediary for acquiring material from the outside world.

In order to consider the relationship between user education and information literacy, the two concepts must be well understood. It should be noted, however, that the concept of User Education and its methods has been discussed extensively above. Therefore, the concept of information literacy will be discussed before considering the relationship between the two terms.

## **Objectives of the Study**

In this unit will be able to understand the:

1. The meaning and definition of user and user education.
2. Educating the user about library and information system and services.
3. Enhance the information literacy among users.
4. Types of academic library users.
5. Analysis of user needs.
6. Planning of user education.

## **Information Literacy and User Education**

In a library or an information center the users are the last links or the recipient of the information in the communication cycle. There are number of terms used as synonyms or near synonyms to users as patron client, member customer. Of these, user is the preferred term.

### **Types of Users**

The users are one type but libraries are different from those of another type. In a public library the users are mainly children, student's, housewives, farmers, retired persons, literates and even also researches. In an academic library the users are students, teachers and researchers, whereas as special groups of users of whom the library is intended. From what is stated above it can be assumed that in the public libraries the users are almost heterogeneous and in academic and special libraries the users are almost homogeneous in nature. For an effective information service as an information manager, he should ascertain about the information requirements of his library users. Information users can be categorized mainly into 4 groups, on the basis of their approach to information libraries, they are:

1. *Potential User*: One who needs information which can be provided by specific services.
2. *The Expected User*: One who is known to have the intention of using certain information services.
3. *Actual User*: One who has actually used an information service regardless of whether he derived advantages from it or not.
4. *The Beneficiary User*: One who derives measurable advantages from information services. User groups may be divided in a number of ways. They can be divided as administratively into internal and external users. Another type of classification of user community on the basis of library service they make use of is the following.

- a) General readers
- b) Subject readers
- c) Special readers
- d) Non-readers users

### **On the Basis of Various Type of Services**

Dr. S. R. Ranganathan has grouped user community on the basis of various types of services enunciated by him. They are, the freshman, ordinary inquirer and specialist inquirer (is one who specialist inquirer and general reader). Here the freshman is the new member of the academic library, ordinary inquirer is ordinary reader and specialist inquirer is one who specializes in narrow field where as general readers are the associated groups. In order to satisfy these groups, Ranganathan has suggested 4 types of services such as initiation or orientation, ready reference service, long range reference and general help to general readers respectively.

### **Non- Users**

There are certain people who because of their style or other environmental problems could not become members of libraries in their vicinity and make use of the library resources. It is the duty of a librarian especially in public libraries to convert non-users or 'on lookers' into potential and habitual users of such libraries. There are a number of ways by which librarian can attract such users into libraries by means of extension activities or other publicity methods. The duty of a librarian is more important to convert non-users into habitual users and would them as capable citizens just like other citizens who are engaged in social development.

### **Nature of Information Need**

Information need is a multi faceted concept which is generally dynamic in users. There are 4 types of information needs or approaches recognized among users. They are:

- 1) *Current Approach*: The current is that which users require to keep abreast of the nascent developments in his fields of specialization / interest.

- 2) *Everyday Approach*: It is the sought of specific piece of information required by the user during day to day investigation in the form of fact.
- 3) *Exhaustive Approach*: It is sought when a researcher wants to have comprehensive detail about a specific topic on the field of study.
- 4) *Brush-Up of Catching-Approach*: Is adopted in situations where a particular user requires information pertaining to related subject fields.

### **User's Characteristics**

Lehman mentioned 8 user's characteristics that, if evaluate, would help the librarian in his efforts to satisfy user need. They are:

1. Functional reading level.
2. Visual level.
3. Personality level.
4. Capacity level.
5. Satisfaction level.
6. Interest level.
7. Variability level and
8. Vocational-a vocational level.

Systematic study of user community will reveal the various characteristics of users seeking information. This will give necessary base guidelines to librarians to serve various types of users groups.

### **User Education**

Education is a long life process, there is no end. As far as library activities are concerns, the users are illiterates. They need some sought of user education on how to use library resources and services. Because the collection libraries are very complicated. To know how to use and what the service available is etc., they must need assistance and guidance (Instructions, Initiation and education). It has its own objectives. Broadly it means to bring the awareness about or to guide the users, about library facilities, collection, services etc., for new users this type of guidance is necessary. Instruction which equips library users with the skills to enable them to be independent and sophisticated users of libraries and their resources. All the activities involved in teaching users how to make the best possible use of library resources, services and facilities, including formal and informal instruction delivered by a librarian or other staff member one-on one- or in a group.

### **General**

A process or programme through which potential users information are made aware if the information sources”.

### **Important Specific Objectives**

- 1) Made aware of the existence of the library, its content, procedures and services.
- 2) Create love and books and reading.
- 3) To provide the scientists with basic skills for information collection that is, current, retrospective, date or facts, information whatever it may be.
- 4) To make the scientists aware of the different information holding agencies.
- 5) To expose the method for strong scientific information collected on different search topics.
- 6) To provide techniques for information search from secondary periodicals, reference sources and other data basis like the online and CD-ROM.
- 7) Able to ascertain the relative merit and demerits of reading materials and reference tools.

- 8) Able to survey the current affairs in the different periodicals on his own.
- 9) Able to understand the time back between the production of information and in its receipt by the user and also availability of various channels of communication between the author and the user outside the preview of the library.
- 10) To provide good foundation for the continued self-education by readers by during their life time.

### **Need for User Education**

Tremendous increase in the volume of publication as well as the resulting complexity of libraries and the methods by which literature is organized and disseminated necessitate the user education. Rapid changes in teaching methods and the resulting trend towards a wider use of multi-media learning resources ranging from the press cutting to slide tapes package and multiple kit. Such format has added new dimensions to the learning process in all types of institutions.

### **Planning for User Education**

Programming and planning of user education programme is very important particularly in academic and research libraries. It needs a careful planning. According to “Thomas G. Kirk” planning of user education programmer enquires four things namely.

- i) Orientation.
- ii) Bibliographic Instruction.

### **Course in Literature Search and Seminars**

Kirk has also mentioned about acquaintance with 6 skills. Viz., reference sources, indexing and abstracting periodicals, library catalogue orientation knowledge, search strategy and subject analysis. As a matter of fact many library scientists have suggested many methods for planning of user education. All these may conveniently be grouped in following broad groups

### **Guiding by Signs and Boards**

#### *1. Orientation*

- i) Introduction to the library.

TABLE I SAMPLE OF SOME SIGNS AND BOARDS

<b>Changing counter books</b>	<b>Periodicals reference</b>
01	100
02	200
03	300
04	400
05	500
06	600
07	700
08	800
09	900

- ii) Introduction to the techniques.
- iii) Introduction to the information sources.

## 2. Literature Search Techniques Evaluation of Users

i) *Guiding Signs and Boards*: Signs and boards are the most potent medium of instruction a board of responsible size, with the work 'library' written on it should be affixed on the top of the library building in such a manner or it's visible from responsible distance. On the gate of the library a board should be displayed containing information about opening hours.

ii) *Lib: Opening Hours*

Monday to Friday.....AM to .....PM

Saturday .....AM to.....PM

iii) *The Library Remains Closed On*

Similarly, single line boards for self-guide section guides should be displayed at appropriate places. Sample of some signs and boards are given in Table I.

## Orientation Programme

Orientation programme includes educating or instructing user in topics like introduction to libraries, introduction to library technique and introduction information sources. Senior library staff or teachers of library science impart education of this type. Though the classes may be short, that is, about 25 - 30 min. Course contents of each of the 3 areas may be as under.

### Introduction to the Library

1. *Library Timing*: Opening and closing hours on weekdays and holidays, close of the day, times for issues and return of books, collection etc., location of various sections, services.

2. *Library Rules*: Number of books to be issued according to category of borrowers, type of books, loan period of reference books, periodicals, general books and other categories of books, overdue charges, reservation of books.

3. *Staff*: Introduction with in charges of each section.

4. *Procedures*: Membership, registration and borrowing procedure.

### Introduction of Library Techniques

Scheme of classification, its features and class number, representing subjects, arrangement of subjects, catalogue inner form, author, title, subject etc., of the catalogue, how to use catalogue, how to find book with the use of catalogue. Shelf arrangement and special collections.

### Introduction to Information Sources

Types of reference books and information contained in this e.g., dictionary encyclopedia, directory of quotations, bibliographical dictionaries, gazetteers, almanacs, subject encyclopedia, subject biography, abstracts, indexes, several publications, demographic sources, standards, primary and secondary information sources use of non-traditional sources.

### Literature Search Techniques

Use of indexing and abstracting periodicals, Thesaurus, citation indexes, style manuals, how to use citation, prepare bibliography etc., introduction to all audio methods.

### Evolution of Users

The users are examined whether they have assimilated the instruction imparted to them. During the course of evaluation, they must be asked to locate, find a particular information and also be put to other search tests.

### **Important Methods**

- 1) Lecture method: may be formal / informal.
- 2) Advertising: (Paper, Journal, Posters, Pamphlets). If it is limited to a particular small geographical area. In case of online and database then it requires very wide advertising through papers, journals etc.
- 3) The workshop: About the CD-ROM, online services
- 4) Newsletters.
- 5) Demonstration method.
- 6) Book exhibition.
- 7) Display of new arrivals.
- 8) Mass media.

### **Conclusion**

User education is one of the important services of the academic library each year for new entrants into the university. It is designed to equip users with information skills that will enable them to make efficient use of library resources and services. The increase in student population, coupled with rapid advances in ICT, has necessitated changes in user education. Lectures, tour, printed guides, displays, seminars and workshops, taped slides, and applications of audio-visual methods are some techniques that are employed in user education. Therefore, incorporating end-user education in academic libraries by developing training programs for the library and information professionals, as well as the end-users, will hopefully improve learning attitudes and network-related competence to use with information and communication technologies thereby helping them to be information literate.

### **References**

- [1] Amkpa S. and Imam A., Library Instruction Programme as a correlate of Student Catalogue use in College of education Libraries, Library Philosophy and Practice, (2011), Retrieved from <http://unllib.unl.edu/LPP/lpp.html>.
- [2] Devarajan G, Library and Information user and user studies. Beacon book, New Delhi.
- [3] John, W. (2008). The effect of library orientation on student usage of the library. Library Hi-tech News 1.
- [4] Lorenzen, M., Encouraging community in library instruction: A jigsaw experiment in a university library skills classroom. Illinois Libraries.
- [5] Onifade N., Busayi I. and Bamigboye B., Teaching the Use of Library as Credit earning course in University of Agriculture, Abeokuta, Library and Information Science Digest: Journal of the Nigerian Library Association, Anambra State chapter, 5, 39-46 (2011)
- [6] Pandey, S.K.S, Library and Society. Ess Ess, New Delhi. Chaturvedi DD, Academic Libraries, Anmol, New Delhi.

# Unveiling the Power of E-Content: Exploring Student Behavioral Change

Dr. Priyanka Suchak<sup>1</sup>, Kausumi Nanavati Mehta<sup>2</sup> and Yash Deliwala<sup>3</sup>

<sup>1</sup>Asst. Professor, <sup>2</sup>Teaching Assistant, <sup>3</sup>Ph.D. Scholar  
<sup>1&2</sup>Atmiya University, Rajkot, Gujarat, India

<sup>3</sup>Darshan University, Rajkot, Gujarat, India

E-mail: priyanka.suchak@atmiyauni.ac.in, kausumi.nanavati@gmail.com, yashdeliwala@gmail.com

## Abstract

*This systematic literature review examines the impact of e-content on behavioral commutation in students. E-content material, encompassing virtual instructional materials and online assets, has witnessed widespread adoption in contemporary instructional settings. Evaluation seriously analyzes studies performed as much as the present year, focusing on behavioral adjustments exhibited via students in response to e-content utilization. Key subject matters explored include the effectiveness of e-content in promoting energetic engagement, customized studying reviews, and fostering self-directed learning behaviors. The overview additionally investigates the effect of e-content material on collaborative mastering dynamics and its role in cultivating crucial questioning abilities amongst students. Furthermore, the evaluation encompasses diverse academic tiers and concern domains, supplying a complete know-how of the extensive implications of e-content material on scholar conduct. Synthesizing findings from various researches, this overview contributes insights into the multifaceted methods in which e-content material impacts behavioral styles in instructional contexts. The discussion of the effects of those behavioral adjustments on motivation, instructional effectiveness, and common learning outcomes offers a nuanced view of the rapidly changing landscape of online education. The evaluation ends with suggestions for future study avenues and the design of effective e-content material tactics to unquestionably influence student behavior.*

**Keywords:** E-content, Behavioral change, Student behavior, Educational Impact, Online Resources, Self-directed learning.

## Introduction

In the dynamic realm of training, the arrival of digital content material (e-content material) has triggered a paradigm shift, redefining the landscape of learning experiences. E-content, encompassing a spectrum of digital sources and substances represents a pivotal pressure in reshaping traditional instructional methodologies. This systematic literature assessment delves into the conceptual nexus among e-content and its profound impact at the behavioral dynamics of students across various instructional domains. At its center, the review explores the transformative ability of e-content to set off behavioral trade— an idea encompassing shifts in student engagement, self-directed mastering inclinations, and collaborative interaction styles. In expertise the elaborate relationship among technology-mediated content shipping and behavioral responses, this evaluate transcends an insignificant examination of tools and systems. It navigates the conceptual underpinnings of the way e-content material becomes a catalyst for redefining scholar behavior within the modern-day educational milieu. The conceptual framework encompasses key dimensions including personalized mastering stories, fostering vital questioning capabilities, and the mixing of technology in collaborative getting to know environments. By adopting a scientific approach, this assessment goals to unravel the nuanced interplay between e-content and behavioral alternate, recognizing the multifaceted nature of this courting. Conceptually, this exploration extends past an insignificant juxtaposition of nice and poor influences, in search of to find the underlying mechanisms that power behavioral shifts. As era will become increasingly more

intertwined with training, knowledge those conceptual intricacies is paramount for educators, policymakers, and researchers alike. The review aspires to make a contribution not most effective to the theoretical foundations of e-content material's effect but additionally to the sensible implementation of strategies that harness its potential to drive advantageous behavioral modifications in students, thereby fostering a dynamic and effective getting to know environment researcher adopted the learning experiential dimensions which enhance online learning (see fig:1).

Learning Experience Dimension	Synchronicity	Face-to-Face Alternative	Face-to-Face Enhancement
Expository	Synchronous	Live, one-way webcast of online lecture course with limited learner control (e.g., students proceed through materials in set sequence)	Viewing webcasts to supplement in-class learning activities
	Asynchronous	Math course taught through online video lectures that students can access on their own schedule	Online lectures on advanced topics made available as a resource for students in a conventional math class
Active	Synchronous	Learning how to troubleshoot a new type of computer system by consulting experts through live chat	Chatting with experts as the culminating activity for a curriculum unit on network administration
	Asynchronous	Social studies course taught entirely through Web quests that explore issues in U.S. history	Web quest options offered as an enrichment activity for students completing their regular social studies assignments early
Interactive	Synchronous	Health-care course taught entirely through an online, collaborative patient management simulation that multiple students interact with at the same time	Supplementing a lecture-based course through a session spent with a collaborative online simulation used by small groups of students
	Asynchronous	Professional development for science teachers through "threaded" discussions and message boards on topics identified by participants	Supplemental, threaded discussions for pre-service teachers participating in a face-to-face course on science methods

Fig.1 Conceptual Framework for Online Learning ((2009), 2009)

**Literature Review**

(White, 2020) The purpose of this study is to determine the effectiveness of adaptive learning technology (ALT) in comparison to traditional teaching methods in an undergraduate learning management knowledge course. Performance is based on Bloom's taxonomy of learning competencies. Previous studies have investigated factors associated with ALT. In one study, students enjoyed using new technology and believed it improved learning. However, there is little research in the literature that shows improvements in comprehension and recall of Bloom's Taxonomy of Learning Competencies definition. The study applied correlations between ALT use and exam/course grades. McGraw-Hill's Connect Learn Smart® was used as the ALT. ALT volunteered for extra credit in class. Correlations were made between Learn Smart® scores and tests. Then, because usage was bimodal (students who took the initiative to complete Learn Smart® and those who did not), an independent sample t-test was conducted between two separate groups. Sampling took place from an information science course at a large university. Data collection methods consisting of recording Learn Smart® scores and test results.

The outcomes of ALT on learning to demonstrate whether ALT improves learning compared to traditional teaching methods. If not, the ALT access value is given. The Results showed no association between ALT use and test/course grades. No differences were found between the two groups (those who completed the ALT and those who did not complete the ALT) on any of the



four tests or final course grades. Since the ALT group made a Learn Smart® alternative, the tool seems to favor learning styles and provides user satisfaction. This is consistent with previous studies. Recommendations for Practitioners were to use the ALT technique for comfort, preference and student satisfaction. Using both traditional teaching methods and newer technological teaching methods can be most effective because they offer the flexibility to find the method that most satisfies the student. Editors and developers of publishing houses must consider the preferences of students when learning.

### *1. Recommendation for Researchers*

Subjects' opinions and perceptions can be misleading. Future research must provide empirical evidence to confirm opinions and insights. Research needs to focus more on student characteristics such as learning style, learning preferences and initiative.

### *2. Implications for Society*

This study suggests that ALT is effective in learning rather than in terms of outcomes and improved learning. Students can learn just as well without ALT. Decisions about using ALT should be based on convenience and student preference.

### *3. Future Research*

In this study, students had the opportunity to complete an ALT. They showed initiative. The initiative must be removed for further research. To confirm the results of this study, random assignments of whether to perform ALT or not should be investigated. Future studies should also use the results of the same subject in both ALT and traditional teaching methods.

(Jamal Abdul Nasir Ansari, 2020). This study is an attempt to explore the applications and utility of social media and mobile devices in transferring resources and communicating with academics in higher education across the border wall, a hitherto unexplained area of research. This empirical study is based on a survey of 360 students at the University of the East Indies, which examines students' perceptions of social media and mobile devices in collaborative learning, interactions with peers and teachers, and its significant impact on academic performance of students. Measurement and instrument validation followed a latent variance-based structural equation modeling approach. The study found that online social media used for collaborative learning had a significant impact on interactions with peers, teachers and online sharing of information. In addition, communication with teachers, peers, and sharing information online had a significant impact on student engagement, which therefore has a significant impact on student academic achievement. Based on this finding, it would be useful to mention that using online social media for collaborative learning helps students to be more creative, dynamic and research-oriented. It is purely a department of knowledge.

(Bernt Arne Bertheussen, 2016). This study examines the effect of student participation in digital learning on the academic performance of 120 students enrolled in an undergraduate finance course. Interactive practice files and exam problems were available for each student and individual download activity was automatically recorded during the first 50 days of the course. Academic performance, as determined by the midterm exam, was strongly related to deliberate practice and problem solving using interactive spreadsheets. In addition, prior math grades predicted future academic success. The results of this study are important for students who are interested in improving their grades and using their time effectively for various learning activities. In addition, educational institutions seeking to share scarce resources between different forms of educational production will benefit from this study.

(Inma Rodríguez-Ardura, 2016). This article empirically investigates the impact of interaction created by e-learning environments on higher education. By considering underlying processes such as imagery, spatial presence, co-presence, and flow, we analyze how interactivity affects users' responses to the learning environment, including their actual continuation behavior. We validate our conceptual model using survey and recorded data from 2,530 open distance university students in the European Higher Education Area. The results suggest that the interactivity created by the online learning environment frees the imagination, which in turn facilitates spatial presence and co-presence and flow. Significant paths are also found from interaction to flow and from flow to online student response variables (attitude, intention to continue and actual continuation behavior). The paper provides new insights into the mechanisms that enable online learning to exist and flow and provides new insights into how HEIs can facilitate online retention behaviors among students.

(J. Broadbent, 2015). As online course enrollment increases, there is a need to understand how students can best apply self-regulated learning strategies to achieve academic success in the online environment. In December 2014, relevant databases were searched for studies published between 2004 and 2014 that examined SRL strategies as correlates of academic achievement in online higher education environments. Of the 12 studies, time management, metacognition, effort regulation and critical thinking strategies were positively correlated with academic performance, while practice, planning and organization had the least empirical support. Peer learning had a moderate positive effect, but its confidence intervals exceeded zero. Although factors that affect achievement in traditional face-to-face events appear to generalize to online settings, these effects appear to be weaker, suggesting that (1) they may be less effective and (2) other, currently unexplored factors may be more important.(SDLR) and (Lasfeto, 2023).

In the context of online learning, students are crucial to the process of learning achievement. Universities must take into account their students' self-directed learning because it may be done online at any time and from any location. Students engage in social engagement via the internet. Four dimensions separate the interaction in online learning: the interaction between the topic and teachers, the interaction between students and students, and the interaction between students and students. This study focused on the connection between students' social interactions in the online learning environment and their self-directed learning. One-way analysis of variance was used to look at statistically significant differences between independent samples and parametric correlation was used to analyze statistical correlations between variables. This study demonstrated a strong correlation between students' preparedness for self-directed learning.

### **Methodology**

The study focused on empirical evidence on e-learning. It is based on systematic literature reviews by following the PRISMA framework. Search Strategy: The search strategy included a systematic review of peer-reviewed articles published in the Google Scholar, Springer, Elsevier, Science Direct, Tandonline, SEI journal, Repository of Alt, UK databases. This search was conducted for articles examining SRL strategies and academic achievement in online higher education environments. The aim was to maximize significant results from articles published in the last two decades.

### **Type of Study**

All studies were to examine the implementation of SRL strategies by students in an online or online course with an outcome variable based on academic achievement. Studies that exclusively used traditional classroom learning, blended/hybrid learning environments, or blended SRL

strategies rather than individualized strategies were excluded. Self-regulated learning strategies that are clearly defined in the SRL literature were included.

### Selection Process of LR

Reports were eligible for review if they specifically examined SRL strategies and academic achievement in online or web-based educational environments. Articles were excluded if no SRL strategy was studied, if more than one SRL strategy was studied together, if the course was not part of an online higher education environment, and if the learning outcome was not used as a grade or if there was no SRL strategy studied in connection with the degree. Authors independently screened the titles and abstracts of identified citations for eligibility. Authors then reviewed the full texts of potential articles for identification. If there were disagreements, we discussed until consensus was reached. We bifurcated papers from total identified database to included papers in this study through prisma model.

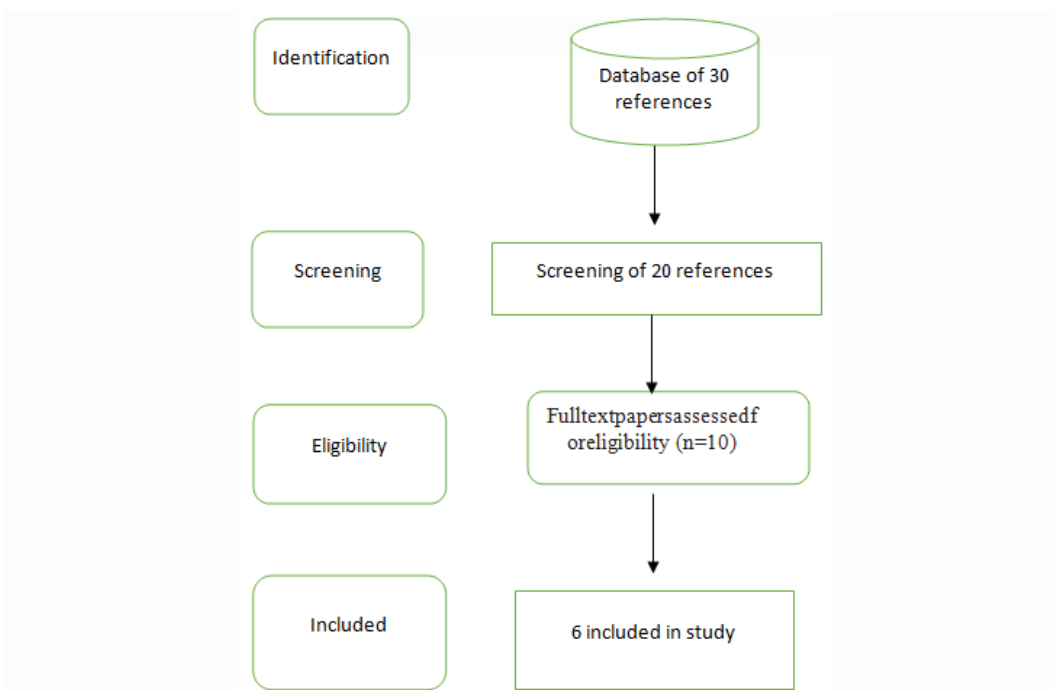

Fig.2 Selection process of LR

### Discussion

As online learning has grown rapidly over the past decade, there is a need to understand how students can best use SRL strategies to achieve academic success in online environments. Self-regulated learning strategies of time management, metacognition, critical thinking, and effort regulation were found to have a significant positive relationship with academic success in the online environment, although these effects were smaller than in the traditional classroom. In contrast, practicing, organizing, and planning were found to be the least empirically supported SRL strategies in an online environment, indicating that these strategies are less useful for online learners. Finally, we argue that improving peer learning should be prioritized in the context of e-learning, and further research is needed to determine the appropriate intervention for this strategy. Future research would be useful to examine how mediating factors (such as motivation)

work together with SRL strategies to improve our understanding of the impact of learner self-regulation on academic achievement in an online environment.

### **Conclusion**

According to the study's findings, elementary instructors use learning methods pertaining to metacognitive awareness, monitoring student progress, and evaluating during SDOL. These strategies are also a useful form of informal professional development for elementary teachers who are currently working in the field. Furthermore, SDOL seems to give primary school teachers a place to grow in their self-efficacy and confidence as literacy instructors. It seems that this is true regardless of how frequently SDOL happens. The ramifications of these findings extend to website developers and organizations who wish to offer instructors chances for online professional development. Giving instructors access to online resources that maximize the use of SDL techniques, such as note-taking, has the potential to improve their teaching tactics, foster professional development, and engage teachers in the process of learning. Participants may have been more effective in their online behaviors and search techniques if they had been asked to think about a literacy-related goal while navigating the web. With regard to their teaching methods and learning strategies, they were able to focus on their objectives.

The discussion of content-specific goals prior to the implementation of SDOL activities in coursework by teacher educators and professional development administrators may boost student engagement and learning. While we did not ask a research question about the virtual revisit think aloud, we did indicate that this approach may be applied to online learning and teaching in a variety of fields. Regardless of the setting or type of learning exercise, researchers studying online teaching and learning can record participants' SDOL using the virtual revisit. New information about informal online learning and the platforms utilized by self-directed online learners can be gained by understanding the tactics employed by online learners as well as the reasons behind their resource access. Furthermore, precise monitoring of target visitors' website navigation can help make better selections and improve the caliber of SDOL opportunities.

### **References**

- [1] [https://repository.alt.ac.uk/629/1/US\\_DepEdu\\_Final\\_report\\_2009.pdf](https://repository.alt.ac.uk/629/1/US_DepEdu_Final_report_2009.pdf)
- [2] <https://slejournal.springeropen.com/articles/10.1186/s40561-020-00118-7>
- [3] <https://www.sciencedirect.com/science/article/abs/pii/S1096751615000251>
- [4] <https://www.sciencedirect.com/science/article/pii/S0378720615001317>
- [5] <https://www.tandfonline.com/doi/full/10.1080/08832323.2016.1140113>
- [6] White, Garry. (2020). Adaptive Learning Technology Relationship with Student Learning Outcomes. *Journal of Information Technology Education: Research*. 19.113-130.10.28945/4526.

# Advancements in Advanced Driver Assistance System Research: Insights from Indian Contributions with Special Reference to Scopus (2008-2023)

M. Sathish Kumar<sup>1</sup> and Dr. L. Santhi<sup>2</sup>

<sup>1</sup>Research Scholar, <sup>2</sup>Librarian (SG),

<sup>1&2</sup>Dept. of Library, PSGR Krishnammal College for Women, Coimbatore, Tamil Nadu, India  
E-mail: sathishbhc123@gmail.com

## Abstract

*Advanced Driver Assistance Systems (ADAS), are technologies integrated into vehicles to enhance safety and improve driving experiences. Using sensors, cameras, and radar, ADAS features include adaptive cruise control, lane departure warning, automatic emergency braking, and parking assistance. These systems aim to assist drivers, reduce the risk of accidents, and contribute to overall road safety. The objectives of the study are outlined, focusing on year-wise distribution, author-wise distribution, top sources, institutional contributions, document types, source-wise distribution, funding agency involvement, and global collaboration. The methodology involves data collection from the Scopus database, resulting in 497 records for the period 2008-2023. The analysis and discussion section explores various aspects, including year-wise distribution, preferred journals, institution-wise distribution, author-wise distribution, document type-wise distribution, funding agency-wise distribution and country-wise collaboration distribution. The results provide a comprehensive understanding of the evolving landscape of ADAS research, highlighting trends, key contributors, and global collaboration efforts.*

**Keywords:** Scientometrics, India, Advanced Driver Assistance Systems, Autonomous Vehicles, Collaboration, Open Access, Funding Agencies, Research Landscape.

## Introduction

The advent of Advanced Driver Assistance Systems (ADAS) has ushered in a new era in automotive technology, transforming the landscape of road safety and vehicular interactions. In light of this paradigm shift, the International Conference on ADAS Research provides a platform for scholars, researchers, and industry professionals to converge and deliberate on the developments, challenges, and innovations within this dynamic field. This article presents a comprehensive analysis of ADAS research in India from 2008 to 2023, based on an exhaustive study of publications indexed in the Scopus database.

The study aims to dissect the quantitative growth and development of ADAS research, offering insights into various facets, including year-wise distribution, preferred journals, institutional contributions, author-wise distribution, document types, source-wise distribution, funding agency involvement, global collaboration, open-access initiatives, and keyword emphasis. By delving into these aspects, the article aims to contribute to a nuanced understanding of the evolving ADAS research landscape, providing a foundation for informed discussions and future directions in this critical domain.

## Review of Literature

Gandia, R. M., *et al.*, (2019) explored the landscape of autonomous vehicles (AVs) through a comprehensive scientometric and bibliometric review, as presented in their article "Autonomous vehicles: scientometric and bibliometric review". The authors conducted an extensive search on Web of Science, identifying a scopus of 10,580 papers, and employed Cite Space for analysis. Their

findings reveal the heterogeneous nature of AV research, showcasing its escalating demand and multidisciplinary character, spanning across 96 science fields. Noteworthy is the observed transition from multi disciplinarity to pluri disciplinarity, with an increased focus on standardized terminology as a contributing factor. The authors recommend future studies to delve deeper into individual search terms and explore identified trends for a more nuanced understanding of the evolving landscape in AV research. Gandia *et al.*, 's work provides valuable insights into the evolving dynamics and potential directions for future research in the field of autonomous vehicles.

Faisal, A., *et al.*, (2021) explored the extensive domain of autonomous vehicle (AV) research in their article "Mapping two decades of autonomous vehicle research: A systematic scientometric analysis". Addressing the challenge posed by the scale of AV research, the authors conducted a systematic scientometric analysis of 4,645 papers spanning the years 1998 to 2017. The paper provides valuable insights into the trends and patterns within the field, shedding light on critical interconnections and their implications for further research. The findings reveal that the majority of AV studies, approximately 87.7 percent, were conducted by educational institutes, with Europe emerging as the most productive continent, contributing 35.9 percent of the publications.

North America, on the other hand, stood out as the most influential continent in AV research, receiving 41.1 percent of the citations. A notable discovery is that over 50 percent of the studies were conducted in the last three years of the analysis period, indicating a recent surge in research activity. The paper emphasizes that despite the growing interest, urban and social contexts of AV research are still in their early stages, and there exists relatively limited collaboration and knowledge sharing between academia and industry.

Faisal *et al.*, 's work serves as a comprehensive guide to understanding the landscape of AV research, offering a foundation for future studies and collaborations in this dynamic and rapidly evolving field.

### **Objectives of the Study**

The main objective of the present study is to analyze the research output of artificial intelligence research in India from 2008-2023 (15 years), based on the publications output as indexed in Scopus database. The following objectives were formulated for the present study:

- 1) To depict the year-wise distribution of advanced driver assistance systems.
- 2) To examine the author-wise distribution of research on advanced driver assistance systems.
- 3) To measure the topmost sources used by scientists for publication in this field.
- 4) To determine the research productivity of the topmost institutions in India.
- 5) To explore the funding agencies' distribution in research on advanced driver assistance systems.
- 6) To investigate the country-wise distribution of collaborative research on advanced driver assistance systems.

### **Methodology**

The data was collected from the SCOPUS Database which is one of the very comprehensive citation databases covering all the aspects of science. The present study attempts to find out the publication pattern of Indian researchers in the field of advanced driver assistance systems. The study aims to analyze quantitative growth and development of advanced driver assistance systems Research in India in terms of publication output as reflected in Scopus database during the period 2008-2023. Over all 497 records were obtained for the period of (2008-2023). Microsoft Excel 2010 was used to analyze data.

## Analysis and Discussion

### 1. Year Wise Distribution

Table I (Year-wise Distribution) illustrates the progressive growth of advanced driver assistance systems (ADAS) research from 2008 to 2023. The total number of articles published increased steadily over the years, reaching 90 articles in 2023, the highest in the dataset, constituting 18.11% of the total publications. The year 2022 follows closely with 94 articles, representing 18.91%. Notably, the years 2019 and 2021 contributed significantly, with 67 articles (13.48%) and 60 articles (12.07%), respectively. While the earlier years, such as 2016, 2015, and 2014, each accounted for 3.82%, 3.62%, and 3.62% of the total publications, they played a crucial role in shaping the overall growth trend. The data suggests a consistent upward trajectory in ADAS research output, reflecting an increasing focus and interest in this field over the analyzed period.

TABLE I (YEAR WISE DISTRIBUTION)

S. No.	Year	No of Article Published	Percentage
1	2023	90	18.11
2	2022	94	18.91
3	2021	60	12.07
4	2020	48	9.66
5	2019	67	13.48
6	2018	43	8.65
7	2017	27	5.43
8	2016	19	3.82
9	2015	18	3.62
10	2014	18	3.62
11	2013	5	1.01
12	2012	4	0.80
13	2011	2	0.40
14	2009	1	0.20
15	2008	1	0.20
		<b>497</b>	<b>100.00</b>

### 2. Author Wise Distribution

Table II, presenting the top 20 author-wise distribution of publications in advanced driver assistance systems (ADAS) research, reveals key contributors to the field. Chitnis, K., leads with the highest number of publications at 11, followed closely by Mody, M., with 10 publications. Choudhary, A., Shirke, S., and Venkataraman, H., share the third position, each with 8 publications. This distribution underscores the individual contributions of authors to the body of ADAS research, with a notable concentration among the top authors. The table reflects a diverse group of researchers, each contributing significantly to the advancement of knowledge in ADAS. The varied number of publications among authors emphasizes the collaborative and interdisciplinary nature of research in this domain, showcasing the collective effort of these authors in shaping the landscape of advanced driver assistance systems.

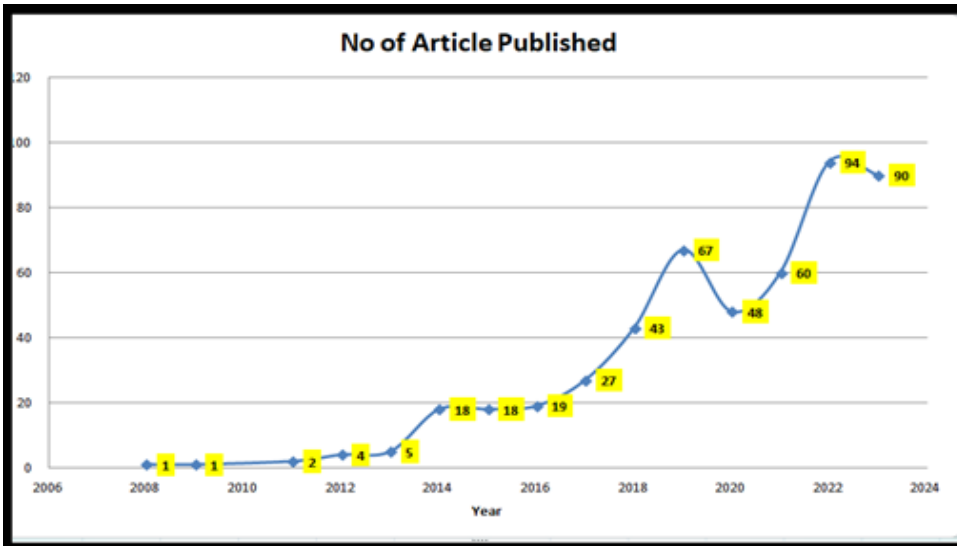

Fig. 1 (Year wise Distribution)

TABLE II TOP 20 AUTHOR WISE DISTRIBUTION ON THE ADVANCED DRIVER ASSISTANCE SYSTEMS RESEARCH

S.No.	Source title	No. of Publication
1	Chitnis, K.	11
2	Mody, M.	10
3	Choudhary, A.	8
4	Shirke, S.	8
5	Venkataraman, H.	8
6	Udayakumar, R.	7
7	Kutty, K.	6
8	Nair, B.B.	6
9	Subramanian, S.C.	6
10	Jagannathan, S.	5

### Preferred Journals by the Scientists of Advanced Driver Assistance Systems

The table II detailing the preferred journals by scientists in the field of Advanced Driver Assistance provides valuable insights into the scholarly landscape of this domain. The most favored journal, with a significant publication percentage of 5.23%, is "SAE Technical Papers," indicating its prominence as a leading platform for disseminating research in the field. Following closely are "Lecture Notes in Electrical Engineering" and "Advances in Intelligent Systems and Computing" with percentages of 2.82% and 2.41%, respectively. The diversity of selected journals, ranging from those specializing in electrical engineering to those focusing on intelligent systems and computing, reflects the interdisciplinary nature of Advanced Driver Assistance research. This diverse journal preference suggests that scientists in this field are actively contributing to a broad spectrum of publications, showcasing the multidimensional aspects of their research across various platforms.



TABLE III (TOP 10 SOURCES FOR ADVANCED DRIVER ASSISTANCE SYSTEMS PUBLICATION)

S. No.	Source	Publication	Percentage
1	SAE Technical Papers	26	5.23
2	Lecture Notes In Electrical Engineering	14	2.82
3	Advances In Intelligent Systems And Computing	12	2.41
4	Communications In Computer And Information Science	11	2.21
5	Lecture Notes In Networks And Systems	11	2.21
6	Multimedia Tools And Applications	7	1.41
7	IEEE Transactions On Intelligent Transportation Systems	6	1.21
8	IEEE Access	5	1.01
9	International Journal Of Engineering And Advanced Technology	5	1.01
10	Eai Springer Innovations In Communication And Computing	4	0.8

### Institution Wise Distribution on the Advanced Driver Assistance Systems Research

Table IV provides a comprehensive overview of the distribution of advanced driver assistance systems (ADAS) research among various institutions. Amrita Vishwa Vidyapeetham leads the list with 29 articles, constituting 5.84% of the total publications, suggesting a substantial contribution to ADAS research.

Following closely, Amrita School of Engineering, Coimbatore, and Vellore Institute of Technology contribute significantly with 23 articles (4.63%) and 17 articles (3.42%) respectively, reflecting their active involvement in advancing research in this field. Texas Instruments India Ltd and SRM Institute of Science and Technology are notable contributors, each accounting for 3.42% and 2.82%, respectively.

The list showcases a diverse range of institutions, including educational institutions and industry players, emphasizing the collaborative nature of ADAS research. This distribution highlights key institutions that play a pivotal role in shaping the landscape of research and innovation in advanced driver assistance systems.

### 3. Funding Agencies Wise Distribution

Table V, highlighting the top 10 funding agencies contributing to advanced driver assistance systems (ADAS) research, showcases the diverse sources supporting research endeavors in this field. The Department of Science and Technology, Ministry of Science and Technology, India, emerges as the primary funding agency with 5 publications, constituting 1.01% of the total publications.

Other funding agencies, such as the Ministry of Electronics and Information Technology and Horizon 2020 Framework Programme, also make noteworthy contributions, each accounting for 0.60%. The distribution includes a mix of governmental bodies, academic institutions, and international programs, illustrating the collaborative nature of funding in ADAS research.

This diverse funding landscape reflects the global and interdisciplinary nature of ADAS research, with support coming from various sectors and organizations.

TABLE IV (TOP 20 INSTITUTIONS OF ADVANCED DRIVER ASSISTANCE SYSTEMS RESEARCH)

S.No.	Institutions	No. of Articles	Percentage
1	Amrita Vishwa Vidyapeetham	29	5.84
2	Amrita School of Engineering, Coimbatore	23	4.63
3	Vellore Institute of Technology	17	3.42
4	Texas Instruments India Ltd	17	3.42
5	SRM Institute of Science and Technology	14	2.82
6	KPIT Technologies Ltd.	14	2.82
7	Texas Instruments	13	2.62
8	Jawaharlal Nehru University	10	2.01
9	Indian Institute of Technology Roorkee	9	1.81
10	Indian Institute of Technology Madras	8	1.61
11	Bharath Institute of Higher Education and Research	8	1.61
12	R.V. College of Engineering	7	1.41
13	KLE Technological University	7	1.41
14	Indian Institute of Information Technology, Sri City	7	1.41
15	International Institute of Information Technology, Hyderabad	6	1.21
16	Birla Institute of Technology and Science, Pilani	6	1.21
17	Indian Institute of Science	6	1.21
18	Indian Institute of Technology Bombay	6	1.21
19	College of Engineering, Pune	6	1.21
20	National Institute of Technology Tiruchirappalli	5	1.01

TABLE V TOP 10 FUNDING WISE DISTRIBUTION ON THE ADVANCED DRIVER ASSISTANCE SYSTEMS RESEARCH

S.No.	Name of the Funding Agency	No of Publication	Percentage
1	Department of Science and Technology, Ministry of Science and Technology, India	5	1.01
2	Ministry of Electronics and Information technology	3	0.60
3	Horizon 2020 Framework Programme	2	0.40
4	Indian Institute of Technology Hyderabad	2	0.40
5	Indraprastha Institute of Information Technology, Delhi	2	0.40
6	Ministry of Education	2	0.40
7	Science and Engineering Research Board	2	0.40
8	VIT University	2	0.40
9	Agència de Gestió d'Ajuts Universitaris i de Recerca	1	0.20
10	Aston University	1	0.20

#### 4. Country Wise Collaboration Distribution

Table VI, outlining the top 10 country-wise collaboration distribution in advanced driver assistance systems (ADAS) research, provides insights into the global reach and collaborative nature of research efforts in this field. The United States leads with 34 publications, constituting 6.84% of the total publications, indicating a significant and dominant presence in ADAS research. The United Kingdom and Germany follow with 10 and 8 publications, contributing 2.01% and 1.61%, respectively. The table demonstrates the international collaboration evident in ADAS research, with countries like Saudi Arabia, Spain, and Iraq making noteworthy contributions. While individual countries may have relatively small percentages, the cumulative global effort is substantial, showcasing the diverse and widespread interest in advancing knowledge and technology in advanced driver assistance systems. The collaborative distribution underscores the shared commitment of researchers from various countries in addressing the challenges and innovations within the ADAS domain.

TABLE VI TOP 10 COUNTRY WISE COLLABORATION DISTRIBUTION ON THE ADVANCED DRIVER ASSISTANCE SYSTEMS RESEARCH

S. No.	Name of the Country	No. of Publication	Percentage
1	United States	34	6.84
2	United Kingdom	10	2.01
3	Germany	8	1.61
4	France	6	1.21
5	Saudi Arabia	5	1.01
6	Spain	5	1.01
7	Iraq	4	0.80
8	China	3	0.60
9	Malaysia	3	0.60
10	Singapore	3	0.60

#### Results and Discussions

This study provides a comprehensive understanding of the evolving landscape of Advanced Driver Assistance Systems (ADAS) research. Table I indicates a consistent upward trajectory in ADAS research output, with a peak of 90 articles in 2023, reflecting a growing interest in this field. Notable contributions in 2019 and 2021 emphasize the sustained focus on ADAS over the analyzed period. Table II reveals diverse journal preferences among scientists, with "SAE Technical Papers" standing out as a leading platform. The interdisciplinary nature of ADAS research is evident from the varied journal choices, showcasing researchers' contributions across different domains. Table III underscores the collaborative efforts of institutions, with Amrita Vishwa Vidyapeetham leading in contributions, highlighting key institutions shaping the ADAS research landscape.

The author-wise distribution in Table IV emphasizes both collaboration and individual contributions, with prominent authors like Chitnis and Mody leading the field. Table V showcases the diverse funding landscape supporting ADAS research, with the Department of Science and Technology, Ministry of Science and Technology, India, playing a primary role. Table VI reveals global collaboration in ADAS research, with the United States taking a leading position. Together, these findings underscore the multidimensional, collaborative, and evolving nature of ADAS research, providing valuable insights for researchers, institutions, and policymakers.

## Conclusion

This article has presented a thorough analysis of Advanced Driver Assistance Systems (ADAS) research in India from 2008 to 2023, with a focus on insights drawn from Scopus-indexed publications. The International Conference on ADAS Research serves as a crucial platform for scholars and industry professionals to converge and discuss the transformative developments within this dynamic field. The comprehensive examination of quantitative growth, preferred journals, institutional contributions, author-wise distribution, document types, funding agencies, global collaboration, open-access initiatives, and keyword emphasis provides a nuanced understanding of the evolving ADAS research landscape. The study reveals a consistent upward trajectory in research output, diverse journal preferences, collaborative institutional efforts, and a global perspective on ADAS challenges and innovations. The findings contribute significantly to informed discussions and future directions in ADAS research, emphasizing its multidimensional, interdisciplinary, and collaborative nature. The wealth of insights presented in this article sets the stage for further advancements in this critical domain, paving the way for continued innovation and safety improvements in vehicular technology.

## References

- [1] Faisal, A., Yigitcanlar, T., Kamruzzaman, M., & Paz, A. (2021). Mapping two decades of autonomous vehicle research: A systematic scientometric analysis. *Journal of Urban Technology*, 28(3-4), 45-74.
- [2] Gamboa-Rosales, N. K., Celaya-Padilla, J. M., Hernandez-Gutierrez, A. L., Moreno-Baez, A., Galván-Tejada, C. E., Galván-Tejada, J. I., ... & López-Robles, J. R. (2020). Visualizing the intellectual structure and evolution of intelligent transportation systems: A systematic analysis of research themes and trends. *Sustainability*, 12(21), 8759.
- [3] Gandia, R. M., Antonialli, F., Cavazza, B. H., Neto, A. M., Lima, D. A. D., Sugano, J. Y., & Zambalde, A. L. (2019). Autonomous vehicles: scientometric and bibliometric review. *Transport reviews*, 39(1), 9-28.

# Research Support Services: A State-of-the-Art Review

Jyoti Sharma<sup>1</sup> and Dr. Deepmala<sup>2</sup>

<sup>1</sup>Research Scholar, <sup>2</sup>Assistant Professor,

<sup>1&2</sup>Department of Library and Information Science,

Mangalayatan University, Aligarh, Uttar Pradesh, India

E-mail: jyotimishra23281007@gmail.com, deepmala.mlis@gmail.com

## Abstract

*The library plays a significantly more prominent role in higher education than primary and secondary education because it is a vital element of institutional education. Dependent on the library network for academic and research purposes. The idea of research supporting librarianship was developed against the background of the academic library landscape's development, the pervasiveness of information, and the flood of information. The primary aim of this study is to review the contemporary literature published related to research support services. Information and communication technologies have also made it easier for authors and researchers to perform their research process faster and to improve the visibility of their work through different online social networking sites and social media platforms. Libraries are playing a pivotal role in dealing with such tools and techniques that can promote the research findings there by maximize the research impact and visibility among the academics.*

**Keywords:** Research, Services, Library Services, Review Literature.

## Introduction

Throughout the beginning of time, libraries have been crucial tools for acquiring, organizing, storing, retrieving, and disseminating information. University libraries are a source of knowledge for scholars at higher education institutions and some outside consumers. These library users typically comprise a sizable population. Sometimes, researchers have an urgent need for information. Information is gathered, stored, processed, and retrieved for use, with the library acting as its powerhouse and engine room (Fabunmi 2004). The library plays a significantly more prominent role in higher education than primary and secondary education because it is a vital element of institutional education. Dependent on the library network for academic and research purposes.

To provide efficient and effective assistance for the educational process, libraries have traditionally embraced recent technology quickly. The library's initiative-taking reaction to the need to change higher education and institution philosophy has sparked a new way of creating learning spaces and coordinating new services. Providing a novel and increased range of assistance, like bibliometric analysis, free access facilitation, and research data management, curation, and preservation, is known as research support. Considered a relatively new field of service delivery by higher education and institution libraries, research supports that librarianship takes on a new and modern shape (Raju & Schoombee 2013).

It has been stated that as libraries are considered the primary source of higher education and institutions for information on scholarly publishing difficulties, librarians need to be ready to respond to inquiries from researchers on this subject (Fruin & Rascoe 2014). The role of libraries is in an excellent position to assist and lead higher education and institutions with the research support service (Kingsley 2014).

Historically, collection growth, information discovery, and some aspects of “information management” have been the focus of library assistance for research (Borrego & Anglada 2018). There is a significant need to raise the value of research in higher education and institutions. As a result, it makes it difficult for libraries to satisfy demand (Maryati *et al.*, 2022).

### **Knowledge Centres**

For future use, the library is a collection of knowledge. There are several mediums available for preserving and recording human knowledge. Previously, paper was considered the most excellent medium for writing or printing documents. However, with the development of science and technology, electronic multimedia is often used in all sorts of libraries, whether “public, academic, national, or special libraries,” to preserve knowledge. Together with human civilization, libraries are dynamic and expanding. Libraries play a crucial role in the educational process in “formal and informal learning, research and development, cultural endeavors, spiritual and ideological spheres, leisure and amusement, etc.”

### **Research Library**

An extensive collection of resources on a single topic or range of topics would often be found in a research library with primary and secondary sources. The idea of research supporting librarianship was developed against the background of the academic library landscape’s development, the pervasiveness of information, and the flood of information. As indicated earlier, Parker (2012) states that “research support” encompasses more than just the conventional provision of services to support students and other people conducting research. She gives a simplistic but clear definition of “research support” as a collection of services and resources that help to improve scholarship and research productivity. A crucial component of the research production cycle, the research librarian brings knowledge and expertise to the procedure to help the researcher and the research output. As a result, the librarian’s role is altered from supporter to contributor to the research process.

### **Research Support Services**

The supplying new services must be aware that data rather than knowledge is increasingly becoming the unit of exchange for learning and research, and this shift is happening very quickly. Although it has traditionally been the library’s responsibility to disseminate intellectual material, this is fast changing. To fulfill the expectations of the second decade of the 21st century, libraries must play a more significant part in the research process by offering a more comprehensive range of services. Data gathering, organizing, and distribution for study are some new services. According to Borgman (2010), libraries’ roles are shifting under this new service paradigm from an “emphasis on reader services to a focus on author services.” In this new distribution (or dissemination) of information framework, libraries play a crucial role. The library gathers, organizes, and makes the higher education and institution’s research output available under the new information distribution framework (or in these roles once on the fringe) (Raju & Schoombee 2013).

### **Role of Library in Research**

The Role of Library in Research is as significant as the role of library in other academic areas. The role of library in research is pivotal, libraries have in-depth resources in the form of books, journals, magazines, articles, and bibliographies. Libraries offer space for students to learn and provide excellent environment for research. Libraries have staff that can help students in locating the information that a researcher might need. In addition to this, most libraries today have systematic digitized information. Unless they provide digital access to the books etc., they cannot maintain their importance in current information age. In recent research it was reported that

electronic and digital services are the most important service that a library can provide to its students. The digital library is a new trend and has added convenience for the students to search any information. Though there is still need to provide other research related support and services to students in order to be more effective.

The most common way to start your research is to have a tour of your local library or online library database. You need to know about the reference room, the card catalog, the periodicals, and the information desk. In this way, you will be able to understand the organization of the library and the ways in which you can get help from there.

There is an enormous growth in the number of publications which are of discipline based, interdisciplinary or multidisciplinary in existence contributing to the advancement of knowledge. Reputation and ranking of any academic or research institution is highly impacted with its scholarly output largely produced by the scientific community. Different parameters are being used to measure the quality of such scholarly output. In most cases, rating research quality relies on the number of research publications and its citations. All scholarly publications arising from academic activities should ensure maximum visibility which can enhance the chances of citations and collaboration. However, the traditional discovery tools are not sufficient any more to facilitate optimum visibility to the research publications and further it constrains the chance of getting connected among the academics. Information and communication technologies have also made it easier for authors and researchers to perform their research process faster and to improve the visibility of their work through different online social networking sites and social media platforms. Libraries are playing a pivotal role in dealing with such tools and techniques that can promote the research findings there by maximize the research impact and visibility among the academics.

### **Review of Literature**

Awan, M. H. *et al.*, (2022) stated that from the beginning of the 2010s, the importance of research support services (RSS), a rising and well-liked portion of university libraries, has been well-recognized. The study attempted to determine the state of RSS offered in Pakistani university libraries and to evaluate the findings with appropriate studies from other countries. A structured questionnaire was created and pre-tested with the help of faculty members, libraries, and national and international research specialists. According to the study's findings, most university libraries offered fundamental RSS and had substantial gatherings of "general and subject-specific works" to satisfy the demands of researchers. Further, most respondents highlighted that libraries should enhance their collection to fulfill scholars' needs and interest in offering RSS.

Maryati, I. *et al.*, (2022) emphasized the crucial function of academic digital libraries in supplying research support services and enhancing research output. No business model can be utilized as a reference for carrying out this role, even though this role has been researched extensively. The study's objective was to create a business strategy and a prototype for the research support services offered by Indonesia's academic digital library. Nine specialists participated in a focus group discussion to determine the essential elements. Using a Business Model Canvas, they were then mapped. The requirements came from literature studies that used "the Preferred Reporting Items for Systematic Reviews and Meta-Analyses (PRISMA)" technique. Information technology, research unit, and library managers were questioned to confirm the needs. The study was the foundation for developing the academic digital library Business Model Canvas and the recommended prototype design, which included a back-office application for librarian services and a mobile application for members. Further study into prototype implementation testing and developing a successful implementation model was required to boost the research.

Padhan, D. K. & Naidu, G. H. (2022) investigated the availability of research support in India's "Higher Educational Institution (HEI) libraries." "Research-related visibility, resources, services, and outreach activities available on library websites were examined to learn about the availability of research support services." The study's conclusions showed that faculty research profiles, institutional repositories, and electronic databases of theses and dissertations favorably rank HEI libraries. On library websites, the relative lack of visibility of these tools and services was a cause for worry. "The Remote Access platform and Training/Orientation of subscribing tools and services" were the extent of the HEI libraries' outreach and promotion efforts. The HEI libraries revealed that incredibly few people used social media services.

González-Solar, L., & Fernández- Marcial, V. (2021) stated that due to multiple internal and external developments, "academic libraries are undergoing a paradigm shift" in their approach to providing services. One of these factors is the maker culture involves difficulties concerning organizing space, infrastructures, and services. The consumers of these services also exhibit a certain informational behavior, which extends to research support services. The study examined whether research assistance services tailored to the age of maker culture have been developed by university libraries. To put the significance of "research support services" in academic libraries into context, it looked at how research is a crucial component of the higher education system. It was investigated if the researcher accepts or rejects the part that university libraries play in the creation and dissemination of research. Authors investigated several aspects of researcher information behavior in the age of maker culture as well as their interactions with librarians as essential steps in the process.

Tang, Y., & Zhang, C. (2021) found that as part of the organizational restructuring that "Peking University Library (the Library)" is carrying out in 2019, the Collaborative Service Center (CCS), which is operated alongside "the talent training system and the process of comprehensive reform, is designated as the supplier of research support services." The two teams at CCS collectively undertake a series of advances in research support services. The study provided an overview of the state of research support services in China as well as library policies regarding these services. The study described the new architecture of "the research support services from four perspectives—service object, service provider, service content, and service strategy—and discusses its intentions and ambitions for more efforts in this area."

Ali, N., & Naveed, M. A. (2020) looked at the present state of the services and resources granted by "Pakistani university libraries for research support." The planned study was carried out utilizing a quantitative research design and a survey methodology. Given that the majority of libraries do not offer cutting-edge research support services, the investigation gave a somber image of the existing position of "research support services" and facilities offered in "university libraries," particularly from the public sector. To be able to offer need-based, cutting-edge "reference and research support services in university libraries in Pakistan," library employees must be strengthened in their ability concerning current tools and skills.

Parmar, S. & Pateria, R. K. (2019) demonstrated the current portrayal of government initiatives in "higher education and the role of libraries" in encouraging their use "for teaching, research, and extension activities in higher education and institutions." In the information and communication technology age, libraries have participated in several movements to support higher education. These movements include "library networks, consortiums, portals, digital collection development, online reference services, digital repositories, online catalogs, and information literacy programs." The study also explained a few of the most important jobs a library plays, including educator, space, individual, knowledge management, etc.



Frederick, A. (2019) found that although regulations are being developed, several university libraries are starting to create structures for these facilities with some scale of accomplishment. Additionally, infrastructure is being built up, library personnel is being taught, and knowledge and activism movements are being undertaken with “academic staff and researchers.” The purpose of the study was to examine how academic librarians view their responsibilities and engagement in RDM support services. In light of this, the researchers employed qualitative techniques and performed semi-structured interviews to collect data. The data were analyzed using a thematic analysis technique. The results showed that Ghanaian academic libraries need to develop their technical know-how and competency sets through training and other programs aimed at strengthening their capacity. Recommendations that can aid the main academic libraries in Ghana in improving were also given based on the findings.

Urkunde, G. (2019) found that the library plays a significant role in higher education. It was crucial to assist readers and researchers from different colleges and institutions nationwide. As a consequence, the position of libraries was crucial for offering essential instruction in the higher education system. Using all of the resources offered by the libraries of the many institutions around the nation was essential, and “the NAAC (National Assessment and Accreditation Council)” involvement in the area of “higher education” was equally crucial. As they pursue the most significant degree of higher education, libraries must participate in the nation’s educational institutions. The study examined libraries’ role in India’s higher education system.

Borrego, A. & Anglada, L. (2018) found that academic libraries’ roles have changed due to the shift from print to digital material. It must re-evaluate how to best serve as partners and intermediates in learning and research. “By studying the three strategic plans published by the Spanish Association of Academic Libraries and a survey administered to library directors,” the study investigated the progression and existing situation of “research support services” in institution libraries in Spain. The results showed that academic libraries are integral to university “research activities and that most rely on vice-rectorates” for scientific or research policy. There was a connection between a library’s size and the services offered to assist research, but there was no correlation between a library’s size and the number of staff members working in this area.

Cox, A. M., *et al.*, (2017) examined the activities, services, and capacities of “research data management (RDM)” in higher education libraries internationally. It covered the findings of a survey that included libraries in “higher education in Australia, Canada, Germany, Ireland, the Netherlands, New Zealand, and the UK.” The findings showed “that libraries” have taken the lead in RDM, notably in terms of campaigning and policy formulation. The growth of “data curation” skills in libraries is ongoing, but the inconsistent use of skills and capabilities is still a problem. Resourcing, collaborating with other “support services,” and getting “buy-in” from academics and senior management are some additional significant issues. To determine “trends and relative maturity levels,” results are contrasted with those from earlier investigations.

The variety of “RDM activities” examined in the study is placed on a “landscape maturity model,” which indicates existing and anticipated “research data services and practice in university libraries.” This model serves as a baseline for future research as well as a “snapshot” of current advancements.

Haddow, G., & Mamtora, J. (2017), covered the scope and kind of research support services offered by “Australian university libraries,” their management, and the variables affecting their creation and delivery in the study. To complete the results with those of an earlier study and to give a more thorough picture of “research support in Australia,” quantitative and qualitative

research methodologies were utilized. The management and difficulties encountered in delivering “research support” are examined in connection to three important themes: services, personnel and resource allocation, and relationships.

Fernández-Marcial, V., *et al.*, (2016) aimed to draw a link between top institutions and the research-focused services provided by their libraries. According to our analysis, the institutions at the top of the list have top-notch libraries that support research activities. The library services of ten of the best institutions according to the ARWU and Times rankings are examined. The most pertinent services to help research processes were determined using a checklist as we observed the websites of the chosen libraries for this study.

Leenaraj, B., & Tuamsuk, K. (2016) conducted a study that was done that was both related to the establishment of “a model for research support services at research university libraries in Thailand.” The government's research strategy, which has placed a greater emphasis on scholarly research within universities, has raised interest in the scholarly research conducted by university libraries. The research sought to understand the variables influencing “the provision of research support services” in Thai research university libraries. According to the research's conclusions based on the descriptive statistical analysis, “information technology” was the most significant component to influence the “research support services” provided by “the library, followed by information resources, users' abilities, service staff, and management.”

Raju, R., *et al.*, (2016) found that academic libraries are now in need of new “research support services include bibliometrics, data management, digital preservation and curation, open access (OA), and open journal publication” as a result of evolving pedagogy and the quick development of related technology. The shifting demands of their research communities for research support have received some attention from “South African academic libraries. Bibliometrics, open scholarship services, and research data management are a few of the common research support services offered by academic libraries” in South Africa. “The provision of research landscape analysis, research week, and research engagement” activities were some of the additional “non-typical research support services and/or activities” that were offered.

Pasipamire, N. (2015) looked into how subject librarians acquire the abilities and know-how necessary to assist researchers in Zimbabwe's new research environment, which includes higher education institutions. The findings of an experience survey technique demonstrated that workshops, conferences, seminars, colloquia on research, personal growth, collaborations, and performing research are all ways that librarians have improved their research abilities. It was shown that the gathering and sharing phases of the study life cycle are when topic librarians' assistance for researchers' peaks. Subject librarians supported researchers in many ways, such as creating institutional repositories, creating awareness campaigns, and teaching information literacy. Due to the size of the student bodies, the absence of assistance from parent institutions, and budgetary limitations, academic librarians faced a variety of difficulties.

Kanzira, A. N. (2015) aimed to look at the potential and problems related to offering “research support services” in university libraries in Uganda. The study is a supplement to established country studies on new practices. At the Consortium of Uganda University Libraries (CUUL), a survey was given to the librarians. The research findings showed that different types of “research support services” provided by the consortium were engaged to diverse degrees. “The provision of research support services” faces many difficulties. The study suggested urging important stakeholders to fund research. Despite its narrow focus, this study provided insights into the type and extent of the research support services offered by CUUL member universities.

Keller, A. (2015) looked at the continuing adjustments made by “Australian university libraries to support research.” After determining the grounds for placing such a heavy emphasis on research support, the study summarized the modifications to libraries’ service portfolios and the modified duties and “responsibilities of subject or liaison librarians.” The study identified and discussed five “research support services: institutional repositories, open access, bibliometrics and enhancing the effect of research, assistance for research students, and research data management.” The study identified three actions or strategies that senior management used to establish and maintain effective and efficient research support services: Student services should be streamlined, liaison librarian activities should be concentrated on “research support, and subject-specific teams” should be established to increase effectiveness and efficiency, and new jobs for research support should be defined. The author investigated in the “Conclusion” section if Australian librarians were free to define their objectives or to what degree government and university policies were affected by Australian libraries.

Corrall, S., *et al.*, (2013) found that academic libraries are being pushed to come up with innovative methods to interact with research communities during the economic slump by advancements in network technology, scholarly communication, and national legislation. With university administrators serving as significant clients and collaborators for bibliometric services, initiatives were addressed at a variety of constituencies. Gaps in knowledge, abilities, and confidence were major roadblocks, and almost everyone agreed that bibliometrics, especially data management, should be included in “professional education and continuing development programs.” The survey also revealed that librarians require a complex comprehension of the research atmosphere.

Raju, R., & Schoombee, L. (2013) looked at research assistance through the prism of how academic library services have changed. The authors reviewed the available literature to identify standards by which to evaluate “the research support services provided by Stellenbosch University.” In the study, authors looked at university libraries’ efforts to define the “deeper meaning of the librarian for the researcher and the research procedure.” The library at Stellenbosch University provides a range of services, including the usage of “research performance management tools to scan the research landscape,” improving self-retrieval of “scholarly literature,” aiding in the publication of “research results,” and aiding in calculating an impact factor. The authors concluded that in this dynamic context of research-creation, university libraries have much to learn and to offer.

Corrall, S., *et al.*, (2012) seek to supplement studies of developing practice from the United States by examining the research support services offered by university “libraries in Australia, New Zealand, the UK, and Ireland.” According to preliminary survey results, the four nations have differing degrees of involvement with various kinds of research support services. However, data management services are reportedly more important in stated plans for library service advancements in the future. Bibliometric support services appear to be more common than research data management at the moment. The study’s findings may also be taken into consideration when creating programs for educating and training the present and next library workers.

Johnson, L. M. *et al.*, (2012) discussed how “the Health Sciences Libraries (HSL) at the University of Minnesota (UMN)” developed and implemented e-science and research support services. The University Libraries’ requirements and possibilities were highlighted by assessing the more significant e-science efforts within the UMN as they develop their expertise, capabilities, and capacity to assist e-research. The University Libraries management and HSL were applying

these lessons learned to help with the expanding demands of health sciences researchers. Several study fields may need better e-science support than are outlined. It also mentioned the strategies for meeting the expanding e-research requirements of health sciences researchers. Hart, G. (2011) stated that academic libraries frequently cited research support as a critical component of their purpose. Nevertheless, given the documented changes in researchers' information-seeking and sharing in the Internet environment, they must consider how their mission statements connect to the researchers' viewpoints. The initiative looked at the expectations of researchers and how they utilize the library at their institution. University of Technology research production has lagged for various historical causes. Therefore, CPUT has prioritized research in recent years. It discovered a strong focus on the typical duties of an academic library, such as managing resources and information. There were a few gaps between what libraries supply and what scholars want.

## Conclusion

The aforementioned assessment of the literature examines how libraries and institutions support a variety of research researchers and students as well as historical research on the framework for the role of libraries in research support services. Several studies that look at how academic libraries support research at higher education institutions are included in the literature review on academic libraries' responsibilities in "research support services". The evaluations cited above go into further detail about "the research support services" and how they affect academic scholarship. The literature reveals the evolutionary journey of libraries from traditional book repositories to dynamic information centers. The emergence of digital technologies and the Internet has significantly transformed libraries into digital knowledge hubs, offering a wide array of research support services. This literature review demonstrates the vital role of libraries in research support services within higher education institutions in U.P. Libraries are no longer limited to physical spaces with books; they have transformed into dynamic centers that provide a wide range of resources, services, and expertise to support research activities.

## References

- [1] Ali, N., & Naveed, M. A. (2020). Research support resources and services in university libraries of Pakistan: A situational analysis. *Pakistan Library Information Science Journal*, 51, 57-63.
- [2] Awan, M. H., Richardson, J., & Ahmed, S. (2022). Current status of research support services in university libraries of Pakistan. *Digital Library Perspectives*.
- [3] Borgman, C. L. (2010). Research Data: Who will share what, with whom, when, and why?.
- [4] Borrego, Á, & Anglada, L. (2018). Research support services in Spanish academic libraries: An analysis of their strategic plans and of an opinion survey administered to their directors. *Publications*, 6(4), 48.
- [5] Corral, S., Kennan, M. A., & Afzal, W. (2012). Changes in academic libraries: Evolution and innovation in research support services. *Libraries in the Digital Age (LIDA) Proceedings*, 12.
- [6] Corral, S., Kennan, M. A., & Afzal, W. (2013). Bibliometrics and research data management services: Emerging trends in library support for research. *Library trends*, 61(3), 636-674.
- [7] Cox, A. M., Kennan, M. A., Lyon, L., & Pinfield, S. (2017). Developments in research data management in academic libraries: Towards an understanding of research data service maturity. *Journal of the Association for Information Science and Technology*, 68(9), 2182-2200.
- [8] Fernández-Marcial, V., Costa, L. M., & González-Solar, L. (2016). Top universities, top libraries: Do research services in academic libraries contribute to university output?.
- [9] Frederick, A. (2019). The role of academic libraries in research data management: A case in Ghanaian university libraries. *Open Access Library Journal*, 6(03), 1.

- [10] Fruin, C., & Rascoe, F. (2014). Funding open access journal publishing: Article processing charges. *College & Research Libraries News*, 75(5), 240-243.
- [11] González-Solar, L., & Fernández-Marcial, V. (2021). Academic Library Research Support Services in the Maker Culture Era. In *Examining the Impact of Industry 4.0 on Academic Libraries*. Emerald Publishing Limited.
- [12] Haddow, G., & Mamtora, J. (2017). Research support in Australian academic libraries: services, resources, and relationships. *New Review of Academic Librarianship*, 23(2-3), 89-109.
- [13] Hart, G. (2011). The role of an academic library in research: researchers' perspectives at a South African university of technology. *South African Journal of Libraries and Information Science*, 77(1), 37-50.
- [14] Heidorn, P. B. (2011). The emerging role of libraries in data curation and e-science. *Journal of Library Administration*, 51(7-8), 662-672.
- [15] Johnson, L. M., Butler, J. T., & Johnston, L. R. (2012). Developing e-science and research services and support at the University of Minnesota Health Sciences Libraries. *Journal of library administration*, 52(8), 754-769.
- [16] Kanzira, A. N. (2015). Chapter Three Research Support Services in Academic Libraries in Uganda: Challenges and Opportunities. *The quest for deeper meaning of research support*, 29.
- [17] Keller, A. (2015). Research support in Australian university libraries: an outsider view. *Australian Academic & Research Libraries*, 46(2), 73-85.
- [18] Kingsley, D. A. (2014). Paying for publication: Issues and challenges for research support services. *Australian Academic & Research Libraries*, 45(4), 262-281.
- [19] Leenaraj, B., & Tuamsuk, K. (2016). Factors Affecting Research Support Services in the Research University Libraries in Thailand. *Journal of Library & Information Science Research*, 11(1).
- [20] Maryati, I., Purwandari, B., Santoso, H. B., Budi, I., Solichah, I., & Gani, F. (2022). Research Support Services in Indonesian Academic Digital Libraries: A Proposed Business Model and Prototype Design. *DESIDOC Journal of Library & Information Technology*, 42(1), 18-29.
- [21] Padhan, D. K., & Naidu, G. H. (2022). Research Support Services in Academic Libraries.
- [22] Parker, R. (2012, February). What the library did next: strengthening our visibility in research support. In *VALA2012 16th Biennial Conference* (pp. 6-9).
- [23] Parmar, S., & Pateria, R. K. (2019). Role of libraries in higher education system in India in 21st century. *Library Philosophy and Practice (e-journal)*, 2993.
- [24] Pasipamire, N. (2015). Research support by subject librarians in selected state university libraries in zimbabwe: accommodating new trends. National University of Science and Technology.
- [25] Raju, R., & Schoombee, L. (2013). Research support through the lens of transformation in academic libraries with reference to the case of Stellenbosch University Libraries. *South African Journal of Libraries and Information Science*, 79(2), 27-38.
- [26] Raju, R., & Schoombee, L. (2013). Research support through the lens of transformation in academic libraries with reference to the case of Stellenbosch University Libraries. *South African Journal of Libraries and Information Science*, 79(2), 27-38.
- [27] Raju, R., Raju, J., & Johnson, G. (2016). Research support services in South African academic libraries. In *Quality and the Academic Library* (pp. 167-177). Chandos Publishing.
- [28] Tang, Y., & Zhang, C. (2021). Cases on Research Support Services in Academic Libraries: Peking University Library. In *Cases on Research Support Services in Academic Libraries* (pp. 247-265). IGI Global.
- [29] Urkunde, G. (2019). Role of Libraries in Higher Education in India. Available at SSRN 3636129.

# Ethics in Research: Concepts, Needs, and Issues in Research Practices

Shabnam<sup>1</sup> and Prof. Savita Kaushal<sup>2</sup>

<sup>1</sup>JRF (Ph.D. Scholar), <sup>2</sup>Department of TT & NEF, IASE,

<sup>1&2</sup>Faculty of Education, Jamia Millia Islamia, New Delhi, India

E-mail: Shabnamnaaz00@gmail.com

## Abstract

*Ethics is the process of questioning, discovering and defending our values, principles and purpose. It's about finding out who we are and staying true to that. It says what is not acceptable. Research ethics may be referred to as doing what is morally and legally right while planning, conduct, and reporting of research. They are actually norms for conduct that distinguish between right and wrong, and acceptable and unacceptable behavior. In present time research is losing its soul due to the lack of ethical practices in research process there is urgent need to raise this concern on various platform among the researcher community. Therefore, this paper attempt to deliberate this topic. The paper uses a survey of secondary data and reflecting on existing body of knowledge about the Ethics in research and ethical concern in contemporary time that affecting the research , this paper undertakes the brief review of concept of ethics in research , Issues and need of research ethics and how to prevent from unethical practices.*

**Keywords:** Research, Concept, Ethical Concern.

## Introduction

Ethics is a branch of philosophy that deals with values as they relate to human conduct. Ethics word Derived from the Greek word “ethos”, which means “way of living”, that is concerned with moral principles that govern a person’s behavior, It is the conduct that tells what is morally good and bad, right and wrong. Ethics is the process of questioning, discovering and defending our values, principles and purpose. It's about finding out who we are and staying true to that. It says what is not acceptable. Research ethics may be referred to as doing what is morally and legally right while planning, conduct, and reporting of research.

They are actually norms for conduct that distinguish between right and wrong, and acceptable and unacceptable behavior. Research ethics are the set of ethical guidelines that guides us on how research should be conducted and disseminated. Research ethics govern the standards of conduct for researchers and it is the guideline for responsibly conducting the research. Research that implicates human subjects or contributors rears distinctive and multifaceted ethical, legitimate, communal and administrative concerns. Research ethics is unambiguously concerned in the examination of ethical issues that are upraised when individuals are involved as participants in the study. Researcher is ethical enough or not to protect the rights, dignity and welfare of the respondents. Researches ethics are set of principles that the research designs and practices.

## Ethical Issues in Research

There different ethical issues may arise at various stages of the research process like, Planning, conducting and reporting of research, Data Collection and interpretation of research data, Methods for reporting and reviewing research plans or findings, Relationships among researchers with one another, Relationships between researchers and those that will be affected by their research, Means for responding to misunderstandings, disputes, or misconduct, Options for promoting ethical conduct in research.

### The Research Ethics

Honesty	Being honest with the beneficiaries and respondents. Being honest about the findings and methodology of the research. Being honest with other direct and indirect stakeholders.
Integrity	Ensuring honesty and sincerity. Fulfilling agreements and promises. Do not create false expectations or make false promises.
Objectivity	Avoiding bias in experimental design, data analysis, data interpretation, peer review, and other aspects of research.
Informed consent	Informed consent means that a person knowingly, voluntarily and intelligently gives consent to participate in a research. Informed consent is related to the autonomous right of the individual to participate in the research. Informing the participant about the research objective, their role, benefits/harms (if any) etc.
Respect for person/respondent	It includes: autonomy, which requires that those who are capable of deliberation about their personal goals should be treated with respect for their capacity for self-determination; and protection of persons with impaired or diminished autonomy, which requires that those who are dependent or vulnerable be afforded security against harm or abuse
Beneficence	Maximize the benefits of the participants. Ethical obligation to maximize possible benefits and to minimize possible harms to the respondents.
Non-maleficance/ Protecting the subjects	Do no harm. Minimize harm/s or risks to the human. Ensure privacy, autonomy and dignity.
Responsible publication	Responsibly publishing to promote and uptake research or knowledge. No duplicate publication.
Protecting anonymity	It means keeping the participant anonymous. It involves not revealing the name, caste or any other information about the participants that may reveal his/her identity
Confidentiality	Protecting confidential information, personnel records. It includes information such as: Introduction and objective of the research Purpose of the discussion Procedure of the research Anticipated advantages, benefits/harm from the research (if any) Use of research Their role in research Right to refuse or withdraw Methods which will be used to protect anonymity and confidentiality of the participant Freedoms to not answer any question/withdraw from the research Who to contact if the participant needs additional information about the research.
Non-discrimination	Avoid discrimination on the basis of age, sex, race, ethnicity or other factors that are violation of human rights and are not related to the study
Openness	Be open to sharing results, data and other resources. Also accept encouraging comments and constructive feedback.
Carefulness and respect for intellectual property	Be careful about the possible error and biases. Give credit to the intellectual property of others. Always paraphrase while referring to others article, writing. Never plagiarize.
Justice	The obligation to distribute benefits and burdens fairly, to treat equals equally, and to give reasons for differential treatment based on widely accepted criteria for just ways to distribute benefits and burdens

## **Issues of Duplication and Repetition of Topic/Study**

### **Measures**

As topics are controversial in their nature so researcher should check whether the topic to be studied has innate ethical ramifications. Thus, before finalizing the topic, the ethical implications of the topic should be given a thought. Ethics play a paramount role in the studies involving direct human contacts. So, the effects of the research on subjects should be given due consideration. Harmful research should be avoided. Researchers conducting studies involving human subjects should be clearly describe and justify the research protocol in the research design Before finalizing the topic the literature Review should be done by the researcher carefully to find out the gape, and to avoid the duplication of research. It should avoid the waste of time energy and resources. Title of the study, objectives, research methodology, sample, population, data collection tool and method analysis of data should be considered carefully appropriately.

## **Ethical Issues of Plagiarism**

### **Measures**

Researcher should properly cite the original source in text citation, reference and bibliography and researcher should act responsibly and take care of copyrights, intellectual property, patents and other forms of rights. Self-plagiarism - copying one's own work should avoid at any cost.

## **An Ethical Issue of Respect for Intellectual Property**

### **Measures**

Researcher should never plagiarize, or copy, other people's work and try to pass it off as their own. Researcher should always ask for permission before using other people's tools or methods, unpublished data or results. Researcher should respect copyrights and patents, together with other forms of intellectual property, and always acknowledge contributions to research. If in doubt, acknowledge, to avoid any risk of plagiarism.

## **Ethical Issue of Conflicts of Interest**

When researcher's interest that are not fully apparent and that may influence judgments, so topic should be selected which is useful and according to interest of researcher to avoid the conflict.

### **Measures**

Conflicts of interest should be discussed in the early stage of research. The researchers should take extra effort to ensure that their conflicts of interest do not influence the methodology and outcome of the research. Researcher should consult an Ethics Committee on this issue if in doubt.

## **Ethical Issue of Study Design and Ethics Approval**

### **Measures**

The study design made by researcher should be well adjusted, well-planned, appropriately designed, and researcher makes sure that research plan should be ethically approved by the research Ethics Committee.

### *1. An Issue of Informed Consent*

#### *Measures*

Researcher should seek consent for the participation from people. In the case of children and few other exceptional cases, the informed consent of participants, as well as their guardians should be obtained. The researcher should reveal all the risks associated with the research to the participants. Researcher should highlight all the negative and positive aspects of the research during the consent



process. Aim, objectives and nature of the research, duration of the study, sponsors and other important information should be revealed to the participants.

### *2. An Ethical Issue of Participants' Safety*

#### *Measures*

Participants' safety should be the prime concern. They should not be exposed to risks greater than they encounter in their normal lifestyle. The researcher should protect participants from the risks arising from their research. The researcher should protect and promote the rights and interests of the participants. Researcher will take care of cultural, religious, economic, psychological, spiritual, physiological, biological, political, social and other issues of the participants.

### *3. Issues of Integrity, Honesty, Objectivity and Openness*

#### *Measures*

To uphold the ethical standards in the research process, the researcher should accept and respect the principles of integrity, honesty, objectivity and openness.

### *4. An Ethical Issue of Privacy, Anonymity and Confidentiality*

#### *Measures*

The privacy, anonymity and confidentiality of the participants and data will be given due consideration. Participants should be given an option of rejecting data-gathering devices like camcorders, audio recorders etc. To make them convenient and easily understandable, the questionnaire and other forms of rating scales should be designed in the native language of the participants. Identity of participant and personal data will not be used and revealed for any purpose. Data should be secure properly should not be leaked at any cost.

### *5. An Ethical Issue of Privacy*

Research should consider privacy concern and the respect for limited access to another person, be it physically, emotionally or cognitively. For example, although participants grant access to their thoughts and feelings when they agree to participate, they do not agree to unlimited access. Therefore, they should have always the right to decline to talk about certain issues or to answer specific questions.

### *6. An Issue of Fabrication and Falsification*

Researcher should avoid the falsification and fabrication of data for this researcher should go in the fields and collect the data honestly and with objectivity without any bias with sincerity.

### *7. An Ethical Issue of Data Manipulation*

#### *Measures*

The data should be collected in a way that doesn't harm or injure anyone. In order to address and sort out all the issues of conflict, a clear and ethically sound plan for data management should be carried out. Besides that, the ethical and truthful collection of reliable data, ownership and responsibility of collected data, and retaining data and sharing access to collected data with colleagues and the public are the three most important ethical issues should be taken care of in data management process. Data manipulation should be avoided.

### *8. An Ethical Issue of Safety and Storage of Data*

#### *Measures*

The Researcher should retain the raw data with as they should be asked for the data at the time of editorial review, or viva of thesis.

*9. An Issues Ethical of Fabrication, Falsification and Misrepresentation of Data and False Reporting Measures*

Appropriate technique should be used for data analysis by the Researcher and should avoid any fabrication, falsification and misrepresentation of data Fabrication, falsification and misrepresentation of result/Reporting. Researcher should not indulge in the manipulation of images or videos or other forms of illustrated work. The researcher should report the data honestly.

*10. Ethical Issues of Veracity (Truth Telling) Measures*

Researcher should follow the principle of truth telling. The researcher should provide comprehensive and accurate information in a manner that enhances understanding. Researchers should always be honest with participants and research work.

**Ethical Issues at the Stage of Writing the Thesis, Publication and Dissemination of Research Study**

*1. An Issue of Lack of Knowledge of Research Ethics Measures*

Researchers should fully try to understand the theories and policies designed to guarantee upstanding research practices and what constitutes an ethical research. With an up-to-date knowledge, the researchers should develop a way with the basic ethical principles ensuring the safety and security of the participants of the study.

*2. An Ethical Issue of Authorship Measures*

Each contributor and supporter should be credited in the manuscript contributed significantly to both the research and writing.

*3. An Ethical Issues of Plagiarism Measures*

Researcher should properly cite the original source in text citation, reference and bibliography and researcher should act responsibly and take care of copyrights, intellectual property, patents and other forms of rights. Self-plagiarism - copying one's own work should be avoided at any cost.

*4. An Ethical Issue of Redundant Publication and Plagiarism Measures*

Redundant publication occurs when two or more papers, without full cross reference, share the same hypothesis, data, discussion points, or conclusions. Researcher should avoid this kind of unethical practice. Researcher should disclose all sources of information, and if large amount of other people's written or illustrative materials is to be used, permission should be sought.

*5. An Ethical of Issues of Objectivity Measures*

Researcher should avoid bias, subjectivity and personal opinion, prejudice mind set and stereotype in any aspect of research, including design, data analysis, interpretation, and peer review. For example, researcher should never recommend as a peer reviewer someone they know, or who they have worked with, and should try to ensure that no groups are inadvertently excluded from the research. Researcher should disclose any personal or financial interests that may affect research.

#### *6. An Ethical Issue of Carefulness*

Researcher should take care in carrying out research to avoid careless mistakes. Researcher should also review their work carefully and critically to ensure that results are credible. It is also researcher should keep full records of research. If they are asked to act as a peer reviewer, researcher should take the time to do the job effectively and fully.

#### *7. An Ethical Issue of Openness*

##### *Measures*

Researcher should always be prepared to share their data and result along with any new tools that have developed when you publish your findings. Researcher should also be open to critics and new ideas.

#### *8. An Ethical Issue of Respect for Intellectual Property*

##### *Measures*

Researcher should never plagiarize, or copy, other people's work and try to pass it off as their own. Researcher should always ask for permission before using other people's tools or methods, unpublished data or results. Researcher should respect copyrights and patents, together with other forms of intellectual property, and always acknowledge contributions to research. If in doubt, acknowledge, to avoid any risk of plagiarism.

#### *9. An issues of Legality*

##### *Measures*

Researcher always should be aware of laws and regulations that govern their work, and should be sure that conform to them.

#### *10. An Ethical Issue of Minimizing the Risks of Research*

##### *Measures*

In all aspects of the research, from recruiting subjects to collecting and storing data to reporting results, risks to research participants should be minimized. Researcher should not Disclose of identifiable sensitive information, researcher should not ask the questions which leads to Emotional or psychological trauma, physical safety, health safety, emotional and mental health well-being should be taken by the researcher.

#### *11. An Ethical Issue of Maintain Validity and Reliability of Research*

##### *Measure*

Researcher should follow the process to ensure the research validity and reliability.

#### *12. An Ethical Issues of Integrity and Transparency*

##### *Measures*

Integrity and transparency are vital in the research. Researcher should share any actual or potential conflicts of interest with Ethics committees that could affect work. Should be honest and transparent throughout the approval process and the research process.

#### *13. An Ethical Issue of Beneficence (doing good)*

##### *Measures*

Research should be carried out to see if some sort of benefit or good can be derived from it, (i.e. contribution to knowledge or improved service/treatment). If no benefit can be derived then the project is unethical.

*14. An Ethical Issue of Non-Maleficence (Do No Harm)*

Researcher will make sure that their research should not harm including everything.

**Conclusion**

After the above discussion we can conclude that Researches ethics are set of principles that the research designs and practices. These principles include voluntary participation, informed consent, anonymity, confidentiality, potential for harm, and results communication etc. every researcher must follow the research ethics if issues arise they can definitely solve them by adopting some measures so that they can prevent themselves from research fraud. Researcher need to be careful, competent and skilled so that they can contribute by their research in knowledge building. Century by using ICT tools and software they can do good and reliable research, so they don't need to do misconduct.

**References**

- [1] <https://research.cc.lehigh.edu/ethical-issues-research>
- [2] <https://www.kirklees.gov.uk/involve/document/EthicalIssues.pdf>
- [3] <https://www.ncbi.nlm.nih.gov/pmc/articles/PMC4453117/>
- [4] <https://www.pearsonhighered.com/assets/samplechapter/0/1/3/4/0134202139.pdf>
- [5] <https://www.scribbr.com/methodology/research-ethics>
- [6] <https://www.skillsyouneed.com/learn/research-ethics.html>
- [7] Research Ethics 2 P2 - Communications Research E-Pg pathshala.

## About the Editors



**Dr. K.S. Shivraj** serves as Chief Librarian at Manipal University Jaipur, Rajasthan, India. He has contributed 40 papers to International and National Conferences and 55 articles to refereed journals. Additionally, he holds the position of Editor-in-Chief for two Research Journals in Library Science and has edited three books. Dr. Shivraj served as Co-Principal Investigator for a DSIR, Govt. of India Project and has supervised four M.Phil and five Ph.D. candidates. Recognized for his contributions, he received the Best Librarian Award from the Indian Academic Library Association in 2012 and the Quality Librarian Award from KL University. He organized three International Conferences in collaboration with universities in Sri Lanka, Dubai, and Thailand, along with several National Conferences and Workshops on various topics. He previously held the position of President at the Rotary Club of Coimbatore Delite and recently received the Top 50 Outstanding Librarians across India award from Ulektz Wall of Fame. Currently, Dr. Shivraj serves as the Editor-in-Chief of the Indian Journal of Information Sources and Services, a SCOPUS indexed journal.



**Dr. Phayung Meesad** currently holds the position of Associate Professor at the Faculty of Information Technology and Digital Innovation and serves as the director of the central library at King Mongkut's University of Technology North Bangkok (KMUTNB), Thailand. He previously served as the Dean of the Faculty of Information Technology and Digital Innovation at KMUTNB. Phayung earned his Bachelor of Science in Technical Education (Teaching in Electrical Engineering) from KMUTNB in 1994, followed by a Master of Science (MS) and a Doctor of Philosophy (Ph.D.) in Electrical Engineering from the School of Electrical and Computer Engineering, Oklahoma State University (OSU), Stillwater, USA, in 1998 and 2002,

respectively. His areas of interest encompass Computational Intelligence, Artificial Intelligence, Machine Learning, Deep Learning, Data Analytics, Data Science, Data Mining, Digital Signal Processing, Image Processing, Business Intelligence, Time Series Analysis, Natural Language Processing, Big Data, and Cloud & Parallel Computing.



**Dr. Akhilesh Kumar Sharma** works as a Professor & Head of Department at Manipal University Jaipur, India. He holds a Ph.D. in Computer Science and Engineering from JK-SPS University, Udaipur, and a postgraduate degree (M.E.) in CSE from Devi Ahilya University (Indore), alongside a bachelor's degree (B.E.) in engineering with a focus on CSE from Rajiv Gandhi Technical University. Dr. Sharma has completed several sponsored projects in R&D, Thrust, and Modernization and has presented research papers, chaired sessions, and delivered lectures at various prestigious institutions including IITs, NITs, and in countries like Vietnam and China. He is a Senior Member of IEEE and ACM, a Member of IEI,

the Computer Society of India (CSI), and a Senior Member of Indo-U.S. Collaboration in Engineering Education (IUCEE), as well as a member of the compliance committee of MIR Labs Washington, USA. In recognition of his contributions to education, he has received awards such as the Best Paper Award from Nanyang Technology University, Singapore, and the Rajiv Gandhi Sadbhavna Award presented by Mrs. Sonia Gandhi at 10 Janpath. Recently, he was honored with the Distinguished Research Excellence Award for the year 2017 by IEAE and also received the Best Research Proposal Award from ACM and CSI in DocCon-2016. Dr. Sharma currently oversees the ACM chapter at Manipal University Jaipur, which has received the Best Chapter Award and a 500 USD award from ACM International NY HQ.



Manipal University Jaipur  
Dehmi Kalan, Jaipur -303007, Rajasthan, India  
Ph: +91-141-3999100 Ext. 179  
[www.jaipur.manipal.edu](http://www.jaipur.manipal.edu)  
e-mail: [karamadai.shivraj@jaipur.manipal.edu](mailto:karamadai.shivraj@jaipur.manipal.edu)

ISBN: 978-81-952757-9-3



978-81-952757-9-3