



## A Review on Hybrid Electric Vehicle Drive Control

<sup>1</sup>Paresh M Sangadiya, <sup>2</sup>Sagar M. Bechara, <sup>3</sup>Mihir D. Gajjar,, <sup>4</sup>Nikunj D Shyara,

<sup>5</sup>Mahesh L Dhola

<sup>1,2,3,4,5</sup>Assitant Professor,

<sup>1</sup>Automobile & Electrical Engineering Department,

<sup>1</sup>Atmiya University, Rajkot, India

### Abstract

The hybrid electric car uses a direct motor drive system in addition to an engine drive system. The fuel consumption of the cars and the waste gas discharges are drastically reduced because to the combination of the engine and the electric motor that powers them. Hybrid is examined in this article. Benefits of electric vehicles, include the main technical component and the way the engine and electric motor are combined. It also examines the actuation patterns of tandem hybrid electric vehicles, parallel hybrid electric vehicles, and hybrid electric vehicles with compound connections. The engine can always be in the best operational condition in a hybrid electric car by using the electric motor as a backup to the engine.

*Key word:* Hybrid electric vehicle; Actuation pattern; Engine; Motor

### 1 Introduction

The battery electric car, the fuel cell electric vehicle, and the hybrid electric vehicle are the three different forms of electric vehicles. The main technology for creating battery electric vehicles is the high energy battery. The electric car currently has a large volume, a heavy battery, and a limited driving range. Moreover, a sizable space is required to construct testing and charging facilities. Hence, it is challenging for local governments, businesses, and users to accept it. While having a promising future, fuel cells are quite expensive and need a substantial investment in construction. China can only conduct a few tests. A hybrid electric vehicle (HEV) is a type of vehicle that combines an electric motor with an internal combustion engine. It is a vehicle type in transition from an internal combustion engine to an electric vehicle. The hybrid electric vehicle has a long engine working duration, strong power, no motor pollution, low noise, and over 10% and over 30% improvements in thermal efficiency and exhaust gas emission.

### 2 The advantages of the hybrid electric vehicle

#### (1) Because there is less pollution and less oil use,

The hybrid electric car uses a direct motor drive system in addition to an engine drive system. The fuel consumption of the cars and the waste gas discharges are drastically reduced because to the combination of the engine and the electric motor that powers them. Currently, the fuel consumption for a hybrid electric passenger vehicle (equivalent to an ordinary passenger vehicle and an intermediate passenger vehicle) is around 3L/100km. The noxious gas released in the waste gas satisfies the need for "the ultra low pollution" emissions, which is in line with the 21st century's early period HEV aim.

Although the HEV's engine has less power than an internal combustion engine car of roughly the same rank, it nonetheless fulfils more stringent requirements for fuel consumption and pollutants from exhaust gas emissions. Also, the car uses the most recent technology to constantly rotate the engine under the most efficient conditions, fully demonstrating the low speed, high torque characteristics of the electric motor, and preventing the engine from starting in an unfavorable environment. The primary characteristics of HEVs are acceleration and ascent.

(2) The hybrid electric car does not require the construction of a ground charge infrastructure, in contrast to the battery electric vehicle. When compared to a battery-powered vehicle, a motor-driven hybrid electric vehicle can travel between 500 and 1000 kilometers after being fully charged with both oil and energy thanks to the accessible traditional internal combustion engine and battery. Hybrid electric drive vehicles launch a function to a battery unit to supplement electrical energy while they are moving. As a result, they do not need to look like electric vehicles (storage battery vehicles), stand still in a garage (or charge stand) for an extended period of time, or build a ground charging station.

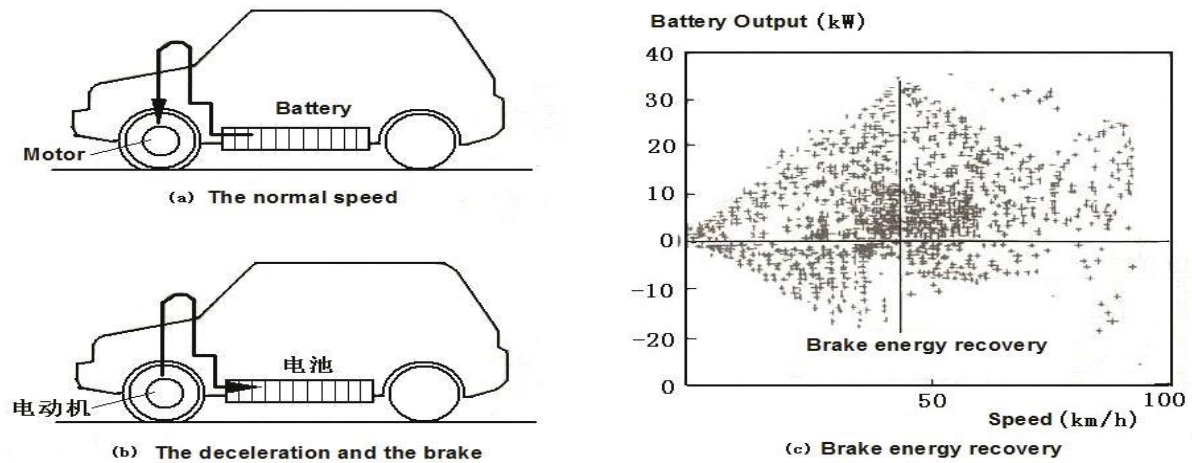

## FEATURES OF HYBRID

- **Regenerative Braking :**
- **Electric Motor Drive/Assist :**
- **Automatic Start/Shutoff :**

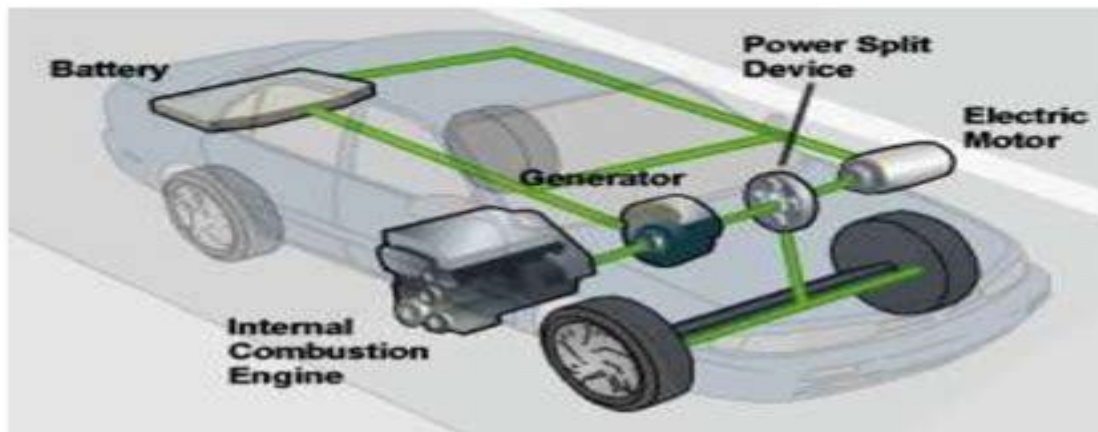

Figure 1. Deceleration and braking energy recovery

### 3 HEV major technique units

(1) Engine HEV may use a two-stroke internal combustion engine, a four-stroke internal combustion engine, or any combination of these. Gas turbines, Sterling engines, rotary engines, and so forth.

(2) Shunt electrical machines, AC induction electrical machines, permanent magnet electrical machines, switching resistance electrical machines, and others may be used in HEV motors. The shunt electrical machine is no longer frequently utilized; instead, induction and permanent magnetism electrical machines are. The usage of the special motor as the drive motor for HEVs and the switch magnetic resistance electrical machine application are both common.

(3) Battery When a HEV uses electricity, it may employ a variety of batteries, including fuel cells, energy storage devices, and super capacitors.

(4) Combination of HEV engines and motors

The composition and construction of a hybrid electric vehicle vary since its power can come from a variety of sources, both alone and in combination. The three primary types of hybrid electric vehicles are:

### 4 HEV engine and motor's combination

#### 4.1 Series hybrid electric vehicle

The engine, generator, and motor make up the series power. According to Figure 2, the series method that joins the SHEV with the power unit system and its group prejudice. The series hybrid electric vehicle's structure is fairly straightforward; electric propulsion is the only mode of propulsion. The engine and the car axle are directly connected without the need for solder, so the engine may continue to operate in a steady, highly efficient, and low-pollution manner. Nevertheless, because the quality, quantity, and power of the series hybrid electric vehicle's parts are all quite large, the installation arrangement is extremely complex at the same time.

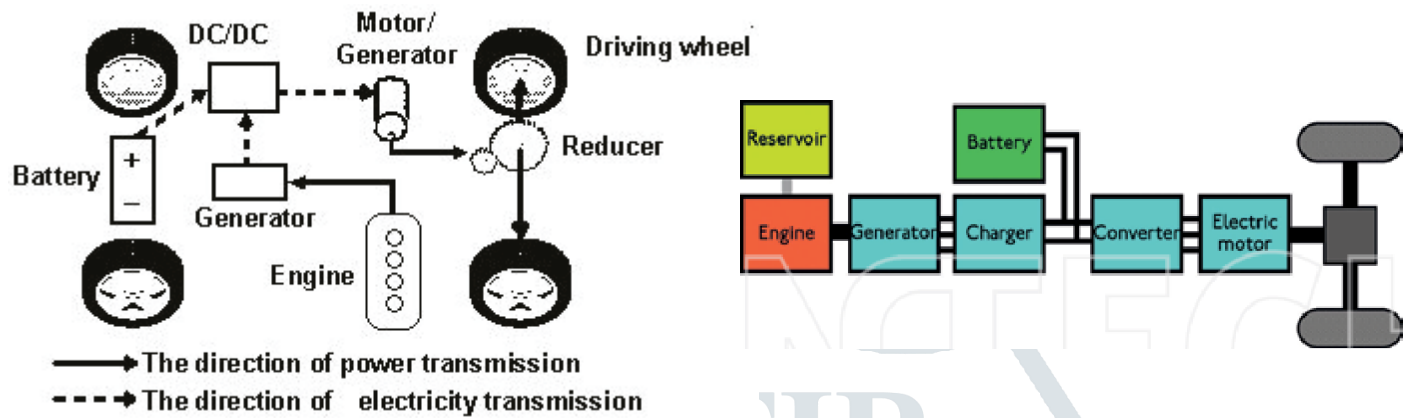

Figure 2. Series Hybrid Electric Vehicle

#### 4.2 Parallel hybrid electric vehicle

The parallel hybrid electric vehicle is equipped with two sets of driving systems: an engine drive and an electric drive seen in Figure 3, both are capable of actuating and driving automobiles. The fuel oil efficiency and emission behavior of the engine are both quite good, and it operates in the highly effective steady state as well. The driving system may select components with low power.

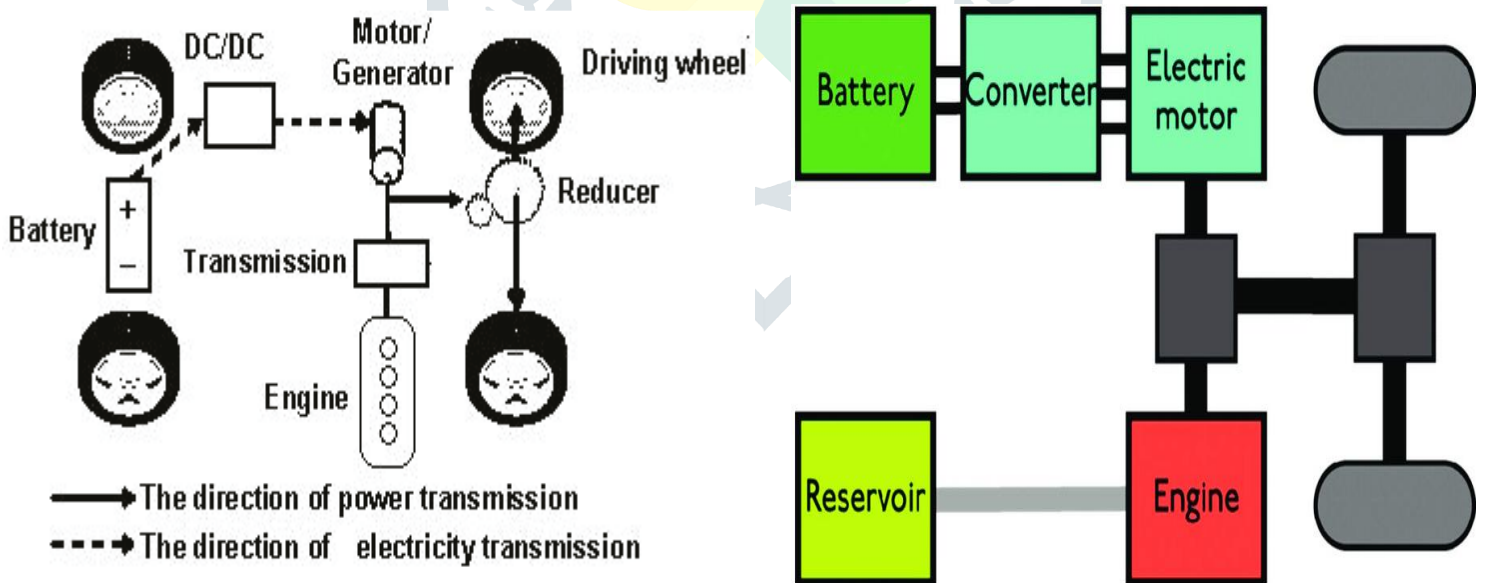

Figure 3 Parallel hybrid electric vehicle

### 4.3 Combination electric/hybrid vehicle

The main characteristic of the combined hybrid electric dynamic system for the structure composition of the combined hybrid electric vehicle as shown in Figure 4 is that the engine may completely shut down when the vehicle starts and travels at the low speed in order to reduce the potential loss of energy.

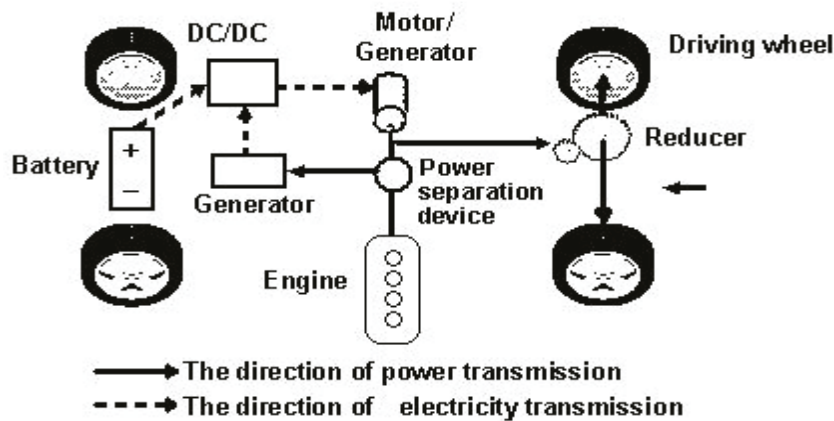

Figure 4 Hybrid electric vehicle.

## 5 Hybrid electric vehicle's actuation pattern

### 5.1 Series hybrid electric vehicle's working pattern

Each component of the hybrid electric car functions in concert with the controller to transmit the various modes in accordance with the driver's commands.

- (1) The vehicle's engine and (or) battery both produce electricity together through the generator and transmit it for the converter before activating the electrically operated generator, which is done through the power transmission actuation wheel. This time, the motor is a generator that is powered by electricity.
- (2) When the load is light and the engine's output is greater than what the wheel needs to drive, the generator's surplus electricity is utilized to charge the battery until it reaches a predetermined level of capacity. This time, the motor is a generator that is powered by electricity.
- (3) During the braking or deceleration phase, the electrically operated generator acts as the generator, converting the kinetic energy of the vehicle into electrical energy and charging the battery through the electrical system.
- (4) The engine charges the battery via the generator and the power converter when the car is stopped.

### 5.2 Parallel hybrid electric vehicle's working pattern

- (1) The engine and motor-generator operate together to power the cars when the vehicle is started or the throttle is fully opened for acceleration.
- (2) During routine travel, the motor-generator is not attached because the engine supplies the vehicle's necessary power.
- (3) The motor-generator acts as a generator to charge the battery through the power converter as the vehicle slows down and brakes.
- (4) When the vehicle is not carrying a heavy load, the motor-generator receives some power from the engine to charge the battery via the power converter.

### 5.3 Combined hybrid electric vehicle's working pattern

- (1) The battery functions to supply the energy the car needs to move when it is started while the engine is off.
- (2) The engine and the motor-generator cooperate at the same time to provide the power the vehicle needs to move forward when the throttle is fully opened and the vehicle is moving at a high rate of speed.
- (3) The engine works to supply the necessary power when the vehicle is moving at its normal pace and the motor shuts off.
- (4) The motor-generator operates in the generator pattern to charge the battery via the power converter when the vehicle brakes or decelerates.
- (5) If the battery needs to be charged while the vehicle is moving, the engine provides some power to propel the vehicle and another portion to the generator via the power converter to charge the battery.
- (6) The engine could charge when the vehicle comes to a stop.

When starting or moving at a low speed, the hybrid electric vehicle utilizes the engine and motor's complementary working pattern. When the engine is off and just the electric drive (compound connection type) is used, the amount of fuel oil consumed by the vehicle is zero. The electric motor will reach its highest torque right after starting. or at the beginning Together, the gasoline engine and the motor operate (in series and parallel), with the engine always in the optimal operating range. The gasoline engine in most cars, however, spends fuel when it starts and only starts to save it when travelling at the proper speed. The engine should therefore be in the finest possible running condition. Due to these features, hybrid electric vehicles consume less fuel and emit fewer emissions during

traffic jams than vehicles with internal combustion engines. The hybrid electric car outperforms electric drive vehicles and continuously recharging pure electric vehicles. The hybrid electric vehicle solves the drawbacks of both pure electric and internal combustion vehicles by combining their benefits. In the future, it will be the most popular type of energy-efficient car.

#### References

- [1] Chen Qingquan□Sun Fengchun, Zhu Jianguang. Modern electric vehicle technology. Beijing: Beijing Institute of Technology Press, 2002
- [2] Liao Quanlai, Luo Yutao. Electric vehicle study. Guangzhou: South China University Press, 1997
- [3] Hu Hua, Song Hui. Electric vehicles. Beijing: China Communications Press, 2003
- [4] Chen Qingquan□Sun Fengchun. Basis for hybrid electric vehicles. Beijing: Beijing Institute of Technology

