

# Retrofitting & Extension of Two Floors in School Building

<sup>1</sup> Shivani Bhadra, <sup>2</sup> Dhvanil Bavishi, <sup>3</sup> Kevin Gondaliya, <sup>4</sup> Arjun Vekariya, <sup>5</sup> Mayank Parekh

<sup>1</sup>BE Student, Department of Civil engineering, AITS-Rajkot, <sup>2</sup>BE Student, Department of Civil engineering, AITS-Rajkot,

<sup>3</sup>BE Student, Department of Civil engineering, AITS-Rajkot <sup>4</sup>BE Student, Department of Civil engineering, AITS-Rajkot,

<sup>5</sup>Asst. prof. Of Civil Engineering Department AITS -Rajkot

**Abstract—** strengthening of the RC columns is required due to the design errors; damage due to earthquake or changes in the functionality of the structure, etc. This project involves the repair and retrofitting of G+3 storey school building and its further extension up to G+ 5 storeys. Due to this extension, the structure may not be able to carry the additional loads acting upon it. Hence for this purpose the existing structural elements should be strengthened. Various retrofitting methods can be used for the strengthening of the building. The most suitable methods for the strengthening of structure are RC Jacketing of the structural members, Fiber Reinforced Plastic bonding method, steel plate bonding method, strengthening by External Prestressing, etc. Retrofitting is used to enhance the load carrying capacity, increases stiffness, strength and ductility of the existing structure. Therefore, the building would result into safe and stable structure.

**Index Terms-** Retrofitting, RC Column, jacketing, Strengthening method.

## I. INTRODUCTION

Retrofitting of the structure is upgrading the existing structure to meet the enhanced structural requirements in terms of load carrying capacity of existing structural elements or by introducing additional structural elements integral to the existing structure. It is method for strengthening of the structural elements. Strengthening is the measures taken for deteriorated structure or any of its structural members to restore its design load carrying capacity. The necessity for strengthening of structure arises due to certain reasons such as change in its load carrying capacities, revised design building codes, weathering actions or change in functionality of structure.

Strengthening of structure is done by adopting various interventions like substitution of some structural elements, introduction of new structural elements, demolition of existing structure or strengthening of existing structure.

Strengthening of the structure can be done by various methods such as- Reinforced cement concrete Jacketing (RC Jacketing), Steel Plate bonding method, Strengthening by External Prestressing, Fiber Reinforced Polymer Composites (FRP), etc.

Therefore, strengthened structure has enhanced durability, improved stiffness, strength and ensures safety.

## II. RETROFITTING

- Structure retrofitting is a process whereby an existing structure is enhanced to increase the probability that the structure will survive for a long period of time and also against earthquake forces.
- This can be accomplished through the addition of new structural elements, the strengthening of existing structural elements. Factors that should be considered in selecting the retrofitting method- includes required performance improvements, the viability of execution of the retrofitting work, the impact of the retrofitting work on the surrounding environment, the ease of maintenance after retrofitting, economy and other factors.
- RC Jacketing: - In this method the entire height of the column section is increased and a cage of additional main reinforcement bars with shear stirrups is provided right from the foundation as per the requirement of additional load, etc.

- The enlargement should be bonded to the existing concrete to produce a monolithic member.
- Cement mortar is used for these enlargements. The section enlargement method is relatively easy to construct and economically effective.



### III. NEED OF RETROFITTING

- Structures designed with old codes
- Structures designed with new codes but deficient in design and construction,
- Important building whose service is essential after EQ, [hospitals, w/s, monumental, schools etc.]
- Purpose altered buildings,
- Buildings which resisted past EQ (becomes weak)

### IV. PRINCIPLES OF RETROFITTING

- Removal of irregularities and asymmetry.
- Increasing the strength and stiffness.
- Enhancement of deformation capacity (or ductility).
- Earthquake demand reduction by Base-isolation or supplemental energy dissipation.

### V. METHODS OF RETROFITTING

Methods likely to be used for the strengthening of the structure can be decided after the several investigations and evaluations, then suitable method ensuring the safety of the structure and protection from the further deterioration.

Various methods for the Retrofitting of the structure are as follows:

- Plate Bonding
- RCC Jacketing
- Structural Strengthening by External Pre-stressing
- Fiber Wrap Technique

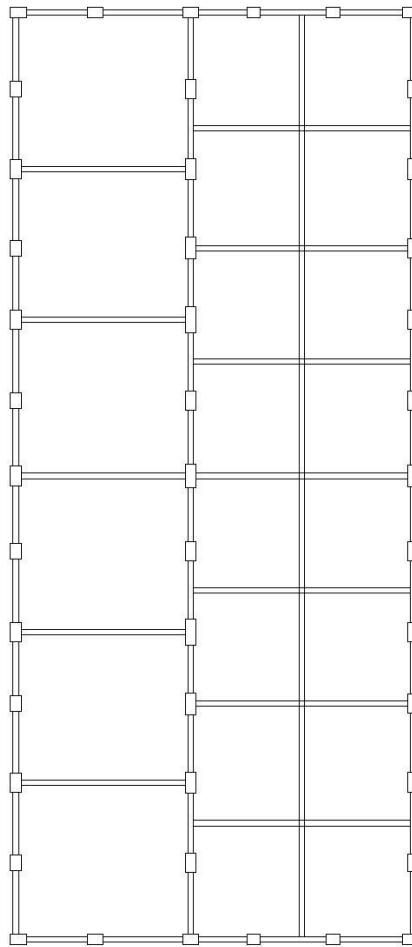
**VI. LAYOUT OF STRUCTURAL PLAN**

STRUCTURAL LAYOUT OF SNK SCHOOL,RAJKOT

**VII. PRELIMINARY INFORMATION**

General instructions of work:

Year of construction	1985
Year of Investigation	2016
Type of structure	Three storied RCC frame structure
Location	Near Aakashvani chowk, University road-Rajkot

**VIII. VISUAL OBSERVATIONS**

- At few places the reinforcement is exposed and corroded.
- Corrosion of the reinforced bars seen in columns.
- Spalling of concrete in RCC columns.
- Reduction in the diameter of reinforcement bars.
- Concrete reinforcement cover seemed to be not enough.

IX. LOAD CASES

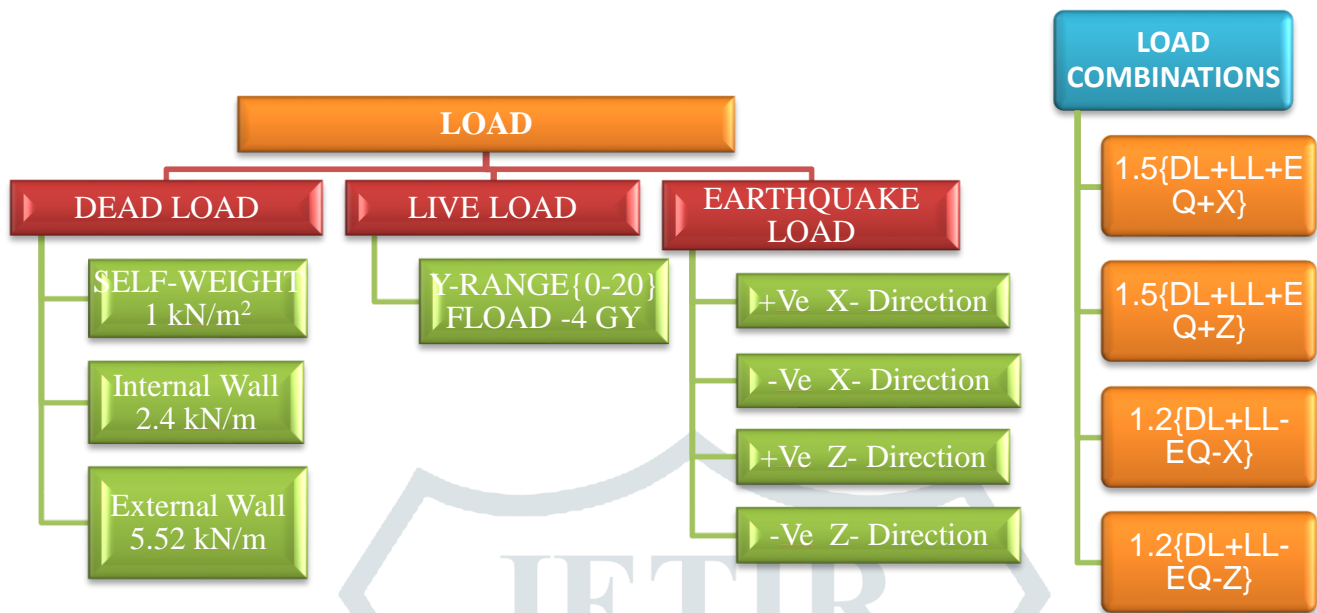

X. COLUMN RESULTS



XI. JACKETED COLUMN SECTION

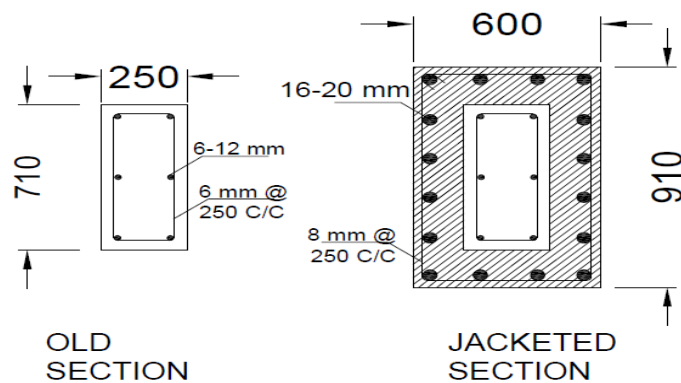

## XII. SOFTWARE RESULTS

C O L U M N   N O .   2 0 1   D E S I G N   R E S U L T S			
M20	Fe415 (Main)	Fe415 (Sec.)	
LENGTH: 1500.0 mm	CROSS SECTION: 840.0 mm X	450.0 mm	COVER: 40.0 mm.
** GUIDING LOAD CASE: 7 END JOINT: 114 SHORT COLUMN			
REQD. STEEL AREA :	4536.00 Sq.mm.		
REQD. CONCRETE AREA:	373464.00 Sq.mm.		
MAIN REINFORCEMENT :	Provide 24 - 16 dia. (1.28%, 4825.49 Sq.mm.) (Equally distributed)		
TIE REINFORCEMENT :	Provide 8 mm dia. rectangular ties @ 255 mm c/c		
SECTION CAPACITY BASED ON REINFORCEMENT REQUIRED (KNS-MET)			
-----			
Puz :	4773.01	Muz1 :	193.79    Muy1 : 386.61
INTERACTION RATIO: 0.91 (as per Cl. 39.6, IS456:2000)			
SECTION CAPACITY BASED ON REINFORCEMENT PROVIDED (KNS-MET)			
-----			
WORST LOAD CASE:	8		
END JOINT: 114	Puz :	4860.50	Muz : 213.44    Muy : 426.37    IR: 0.81

## XIII. CONCLUSION

- As per data validation for portal frame, it shows that results obtained from manual and software analysis are almost similar.
- Therefore, modeling of G+ 3 storey is carried out in STAAD PRO.
- Laboratory test results for compressive strength of core specimen taken from school building is 70% less than required compressive strength.
- The existing G+3 design of the building without considering earthquake loads has 6-12mmØ and 6mmØ stirrups @250mm c/c and the equivalent design obtained from STAAD PRO shows that 8-12mmØ and 8mmØ stirrups @190mm c/c is required.
- As per the results obtained from the analysis of the existing design, the building is strengthened using Retrofitting method and its extension up to two floors is carried out.
- The designed obtained for column was for total jacketed section so designed for retrofitted section can be obtained after deducting the design of old section.
- After considering Earthquake loads the design results of G+5 storey building obtained are 24 -16mmØ, and the equivalent design from STAAD PRO obtained is 24-16mmØ and 8mmØ stirrups @255mm c/c.
- After application of all loads (DL, LL, and EQ) and the extension of the building, the retrofitted structure can withstand against loads.
- Further, the results of design of structure as per the Indian Standards and the extension of the building up to G+5 storey.

**XIV. REFERENCE**

- [1] “Handbook on repair and rehabilitation of RCC buildings”, Central Public Work Department, Government of India.
- [2] “Guidebook on Non-Destructive testing of concrete structures” by International Atomic Energy Agency, Vienna,[2002]
- [3] Dr. H.J. Shah and Dr. Sudhir K Jain, Design example of a six storey building.
- [4] “BUREAU OF INDIAN STANDARDS” Indian standard codes :- IS 15988-2013, IS 456:2000 , IS 875:1987(Part I-V), IS 13920:1993 ,
- [5] “BUREAU OF INDIAN STANDARDS” IS 1893:2002, SP-16
- [6] “CONCRETE LIBRARY No.95” Guidelines for retrofit of concrete structures( draft)
- [7] [published by JSCE, September 1999]
- [8] “ES JULIO, F BRANCO and V D SILVA” Structural rehabilitation of column with reinforced concrete jacketing [Prog. Struct. Engng Mater. 2003; 5:29–37 (DOI: 10.1002/pse.140)].
- [9] “Sachin S Raval, Urmil V Dave” Effectiveness of Various Methods of Jacketing for RC Beams [Procedia Engineering 51 (2013) 230 – 239].
- [10]“Guneyozcebe,Ugurersoy, Turgul Tankut,Ugurhan Akyuz and Emrah Erduran” Rehabilitation of Existing Reinforced Concrete Structures using CFRP Fabrics [August 1-6, 2004 Paper No. 1393]
- [11]“K.P.Jaya, Jessy Mathai” Strengthening of RC Column using GFRP and CFRP
- [12]“Allan Hutchinson Hamid Rahimi” Concrete Beams Strengthened with Externally Bonded FRP Plates

**XV. BIBLIOGRAPHY**

- I. Guidebook on non-destructive testing of Concrete structures (IAEA, Vienna,2002)
- II. Method of externally strengthening concrete columns with flexible strap of reinforcing material.
- III. (Patent no. :- US 6,219,991 B1)
- IV. Method of enlarging existing building (Patent no. :- JP2000314237A)
- V. Method and apparatus for Strengthening the concrete Elements using prestressing Confinement (Patent no. :- US 6,718,723 B1)
- VI. Repair of damaged concrete Columns or other structures Using fast curing, fiber reinforced Polymer composites.
- VII. (Patent no. :-US 2004/0067335 A1)
- VIII. Method for retrofitting reinforced concrete column using multi-layered steel plates, and retrofitting structure of
- IX. Reinforced concrete column using the same (Patent no. :-US 8,281,545 B2)
- X. A Piling wrap (Patent no. :- EP 1668191 A1)
- XI. Strengthening method for reinforced concrete column (Patent No.:- CN 104389439 A)
- XII. Rehabilitation and retrofitting of building structures
- XIII. (Uma Shankar .K, Arun Prakash .K & Pradeep Kumar .S
- XIV. Assistant professor, knowledge institute of technology, Salem, Tamil Nadu, India)